

External lightning protection  
Insulated lightning protection  
Earthing material  
Surge protection

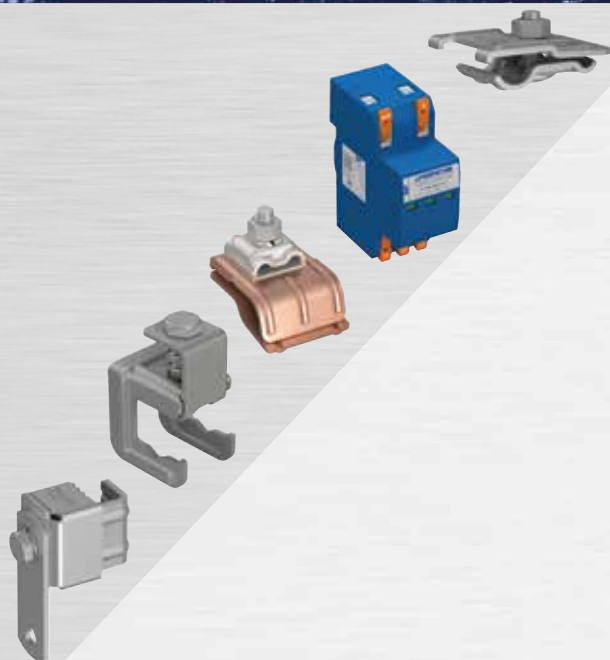

*Always safely  
one idea ahead!*





# **J. Pröpster GmbH** *a strong family business* *– past, present and future*



*Humaneness & emotion*

shape our thinking, our actions and our company culture. A company I like to visit, where I find more than I expected and people who listen to what I am saying.



*Reliability & honesty*

are our outstanding characteristics. Without fail you receive tried and tested quality. You can rely on us for honest opinions and competent promises.



*Respect & trust*

form the basis of our mutual high regard. With the customer in mind, we find solutions to problems and fulfil wishes quickly and effectively. Your contacts here are specialists who actively support you in achieving your goals.



*Joy & enthusiasm*

are both the driving force and the guarantee of success. You are held in high esteem and recognition by people who take pleasure in working towards your success. You can share this joy and experience our enthusiasm.



## Our promise "Always safely one idea ahead!"

does not only encompass innovations and inventions, but also facilitates work processes, safety and quality at extremely stable prices with high availability.



Quality is also a priority to us when offering support for projects and providing you with reasonably priced custom-built components and a perfect delivery service.

Our free winter seminars (training sessions, not sales events!) are always well-attended with great feedback.

Since our company's foundation over 40 years ago, you, the customer, have always been at the heart of our thoughts and actions.

### *Additional production and warehouse facilities*

3 km to the south of our main site at the road St 2660 (B8), 6 double halls with ca. 20,000 sqm floor space were erected in the industrial area C1 to meet our future growth in conjunction with new developments and product improvements.



Factory I Neumarkt



Factory II Frankenberg



Factory III Deining



## Inventions and innovations in lightning protection by J. Pröpster from 1979 - 2021.



According to the slogan of our company

**„Always safely one idea ahead!“**

with numerous inventions and innovations, we have developed lightning protection components since 1980 which were previously neither available on the market nor required by the standards. Easy mounting systems, multifunctionality, high quality standard and long life were rare up to this time.

The following examples will make you - a skilled lightning protection specialist - quickly realize the benefits of our products for yourself and your customers.

### 1980 Straightening device for strips

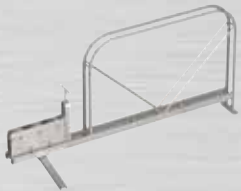

Essential for the installation of flat strips used as a foundation earth electrode or ring earth electrode.

- Benefits:**
- Uncoil, straighten and install in one step.
  - Operated by one person.
  - Time saving up to 70%.

Page 172

### 1981 System Multi-clamp



The **original Multi-clamp** was invented by J. Pröpster in 1981, millions of which have been installed worldwide ever since. It is the most varied lightning protection component and the centerpiece of the multifunctional system of J. Pröpster. Huge benefits for planning, storage, installation, calculation, installation time and price.



T-connection    cross-connection    parallel-connection    end to end connection    stem clamp    trestle    Multi-Plus as terminal clamp

Page 89

### 1982 System USV-clamp



Easy-to-assemble connection system e.g. for earth conductors in concrete. Universal connection clamp for flat and round conductors e.g. 30 x 3.5 mm / ø 10 mm.

- Benefit:**
- Considerably shorter and easier installation in high quality.



flat/flat connection    flat/flat T-connection    flat/round parallel connection    flat/flat connection and round T connection    flat/flat/round cross connection

Page 112

### Systematic introduction of aluminium alloy components



AlMgSi 0.5 as lightning protection down conductor ø 8 mm with appropriate clamps and holders made of aluminium and screws made of stainless steel.

- Benefits:**
- High electric conductivity.
  - Low transport weight (0.135 kg/m; weight per ring 15-20 kg).
  - Good mechanical strength (150 - 160 N/mm<sup>2</sup>).
  - Good resistance to corrosion.
  - Easy and fast installation.

Page 39



1982

## Introduction of stainless steel wires and strips

made of 1.4301 (stainless steel V2A) and 1.4571 (stainless steel V4A) for earth termination systems instead of lead coated material.



Page 38-39



## Invention of a complete product series made of stainless steel: Clamps, pipe clamps and holders for lightning protection and earth termination systems

## SK - conductor fastener

made of aluminium and copper-alloy for a decorative appearance.



Page 66

1983

## System Multi Plus (J.P. patent)

A further development of the original Multi-clamp, with an additional large contact surface (10 cm²) for all wire connections and also as a metal sheet terminal clamp.



Page 88

## System Bimetal (J.P. patent)

The ideal system -standard conform- for all connections and terminals between different materials.

**Benefit:** • Non-corrosive connections between copper conductors and components made of a different material e.g. aluminium or hot-galvanized steel for earth lead-in rods, test joints, skylights and metal constructions.



Page 102-103

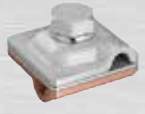

Multi clamp



Vario-clamp



Gutter connection clamp



Saddle clamp

## System Vario-clamp

The **original system Vario-clamp** is a practical solution for the connection of differently shaped conductors. All components are manufactured using stamping technology and are inter-changeable.



Page 96



ø 8-10/8-10 mm



ø 8-10/16 mm



ø 8-10/30x3.5 mm  
ø 8-10/40x4 mm



30x3.5/30x3.5 mm  
40x4/40x4 mm



## 1984 System Diagonal-cross clamp



Page 112

The easy-to-assemble connection system for earth conductors flat/round.

- Benefits:**
- Shorter and easier installation.
  - Two screws M10 with anti-turn device.

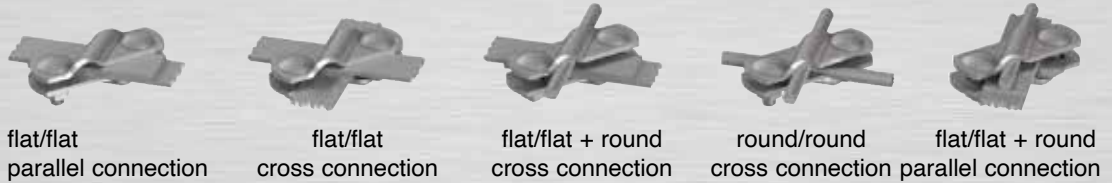

## System Niro-Clip (J.P. patent)



Page 64 ff.

The **Niro-Clip** conductor fastener - made of 100% stainless steel - used as a roof and wall conductor fastener.

- Benefits:**
- Maximum mechanical strength.
  - 100% weather resistant.
  - Easy to use: Simply push in the wire and it is secured as if it were screwed.



## Trapezoidal support - 100% stainless steel



Page 75 ff.

For running conductor lengthwise and crosswise, stability due to trapezoidal double support and embossing.

## Roof conductor holder with clamping bracket



Page 73

for slate roofs.

## Earth lead in rods with terminal lug - insulated



Page 111

Welded connection from  $\varnothing$  16 mm to  $\varnothing$  10 mm, hot galvanized and additionally protected against corrosion by a shrink-on tube in the dry/wet area of earth entry.

- Benefits:**
- Significantly time saving and easier installation.
  - Direct connection to the ring earth electrode.
  - No inconvenient screwing, welding and winding on the building wall
  - The terminals can be easily bent into shape.
  - No need for a connection in areas with a high risk of corrosion.

## Fixed earthing terminals with different connections



Page 123

- Benefit:**
- Completely safe, corrosion resistant earthing terminal - large contact plate  $\varnothing$  80 mm made of stainless steel.

## 1985 Universal downpipe clamp



Page 107

For cutting as required – incl. 7 pre-cuttings  $\varnothing$  9 mm and markings - only 2 downspout clips are sufficient for all common downpipes.

- Benefits:**
- Space-saving storage.
  - Universal usage.

## Wedge connector with catch



Page 118

For the connection of earth conductors flat/flat and flat/round in concrete. Installation note: Wedge has to be installed crosswise to the top conductor.



1986

## Duo-Gutter clamp (J.P. patent)



- Benefits:**
- Large contact surface.
  - Only 1 screw M10.
  - With double terminal clamp - also conductor connection possible.
  - Significantly shorter and easier installation.

Page 93

1987

## Straightening device for round wires and strips

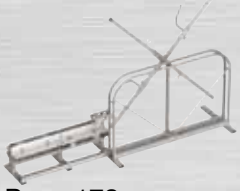

- Benefit:**
- Levelling rolls easily adjustable, for use with wires with different degrees of hardness

Page 172

1988

## Roof conductor holder (J.P. patent)



- Benefits:**
- Brilliant simplicity.
  - Stable due to trapezoidal shape with double support.
  - No screw.
  - No plastic; entirely made of stainless steel.
  - Quick and easy installation.

Page 74

1989

## PRÖ COLOR

Coated lightning protection components in different colours for a more decorative look.



Page 83-85

1990

## Complete programme of earthing busbars and equipotential bonding bars



For industrial use and power supply.

Page 133 f.

1991

## Öko 1-Roof conductor holder for flat roofs



With frostproof natural stone filling

- Benefit:**
- Easy to recycle

Page 81

## Parallel and cross-terminal clamp



Ideal for the connection of a fixed earthing terminal to the reinforcement.

- Benefits:** Installation is possible in just 2 steps, because of 2 threaded bolts M10x60 mm in the middle plate:

1. Connect the foundation earth electrode to the reinforcement and
2. Connect and fix the fixed earthing terminal to the reinforcement - parallel and cross connection possible!

Page 127

1992

## Öko 2-Roof conductor holder for flat roofs (J.P. patent)



Pressed concrete block

- Benefits:**
- 100% recyclable
  - Conductor holder can be fixed onto synthetic roofing membranes with securing strips.

Page 81



1993

## Air termination rod as system component for the insulated lightning protection

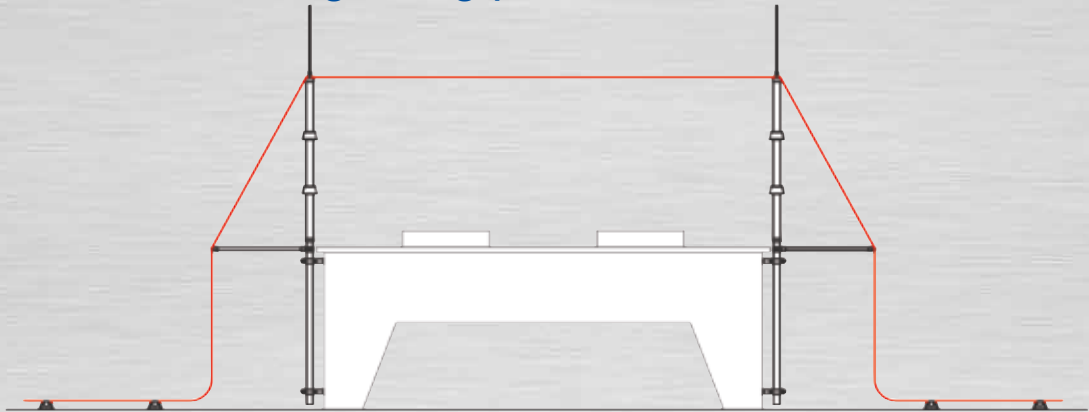
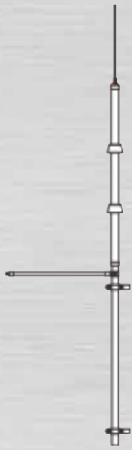

Page 136-137

## Roof conductor holder-universal (J.P. utility patent)

- Benefits:**
- Attractive appearance.
  - Suitable for all sizes of tiles.
  - Conductor holder universally adjustable.



1994

## DIN ISO 9001 certification

Certification of factory I Neumarkt and factory II Frankenberg/SN according to DIN ISO 9001 by the DQS and also EN 29000 for 16 European countries.

1995

## Metal sheets terminal clamp (J.P. utility patent)

Designed for damage-free and lightning-current bearing connection to different types of sheets, in particular thin sheets or soft connecting materials.



Page 98

1996

## Optimal air termination rod $\varnothing$ 16 mm / $\varnothing$ 10 mm

- Benefits:**
- Attractive appearance - optimal static design.
  - Ideal coordination of protective effect and materials input.
  - Minimum surface area exposed to the wind and maximum protection.
  - Reduced load pressure on roof covering and insulation.



Page 43

1997

## ISO-Fugal - down conductor wire $\varnothing$ 8 mm

With halogen-free plastic coating.

- Benefit:**
- Time saving due to easier and faster processing compared with  $\varnothing$  8 mm steel wire with pvc-coat and also better conductivity.



Page 39





1998

## Lightning current arrester P-BM, type 1 (J&P patent)



- Benefits:**
- On spark gap basis, smallest encapsulated type 1 arrester (35 kA) in the world, to protect electrical installations against direct lightning current.
  - High energy, encapsulated, non-exhausting spark gap.
  - Test according to standard in certified testing institutes with current pulses of the high-energy curve shape 10/350  $\mu$ s.
  - Multipole specification, dimensioned for a maximal lightning current of 100 kA in all mains systems.



1999

## Test badge for lightning protection system



For disconnection clamps and conductor holders, for the regular documentation of tests.

Page 106

2000

## Niro-Clip with loose conductor leading (J&P patent)



**Benefits:** • The lightning conductor remains straight despite the temperature-related longitudinal adjustment.

Page 64 ff.

2001

## Saddle clamp (J&P utility patent)



For secure connection to metal sheets and steel constructions.

Page 98

2002

## Öko 3-Roof conductor holder for flat roofs (J&P patent) with stainless steel clip



- Benefits:**
- High quality: Stainless steel clip with loose conductor leading.
  - Specification: Compressed concrete block (weight: 1.2 kg).
  - No frost-sensitive cavities and recesses - totally frost-proof and 100% recyclable.

Page 81

## Roof conductor holder with tension springs (J&P patent)

Universally useable for ridge tiles.



Page 79

2003

## Earthing kits for lightning protection systems and railway, bridge and tunnel constructions which are approved by the federal railway authority EBA



Page 128-129

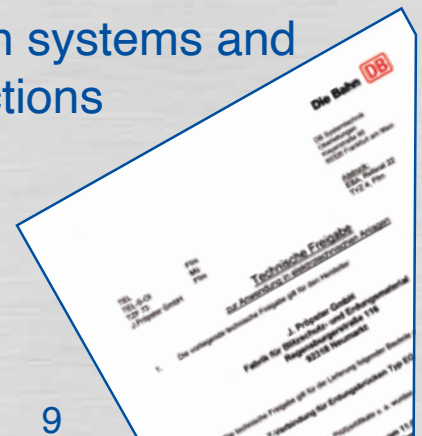



2003

## Combined lightning current and surge arrester P-HMS type 1+2 (class I+II)



- Benefits:**
- Reasonable and practical lightning current and surge arrester for internal lightning protection.
  - High energy varistor technology for the highest surge withstand.
  - Use as a combined lightning current and surge arrester type 1+2.
  - No danger of follow currents due to arrester with varistor technology.
  - The surge protective device does not only responds to lightning currents, but also to switching surges according to the varistor characteristics.



## Fixed earthing terminal system (J.P. patent)

- Benefits:**
- Easy installation with flexible connections, flat and round.
  - Non-corrosive connection with stainless steel external contact.
  - Also suitable as test joint.



## Terminal clamp, heavy-duty type (J.P. patent)

- Benefits:**
- Contact stable connections to steel structures with max. 52 mm clamping range.
  - Variable connections through rotating terminal lugs (360°).
  - Connection with KS-Clamp, Vario-clamp or punched strip possible.
  - Ex area (zone 2/22): The clamp (EN 63305-3 Bbl. 2) is protected against self-loosening.

Page 101

2004

## Roof conductor holder for Kalzip-roofs (J.P. patent)

The reasonably priced solution for fixing conductors to round seams.



Page 77



## Clamps and pipe clamps for safe (J.P. patent) connections in hazardous areas

Not yet fully realized because of lack of test specification.



## Screwless tape conductor holder (J.P. patent)

The reasonably priced and practical solution for fixing of 30 mm flat strips.

- Benefit:**
- Less work - insert the strip, bend the lug - ready.

Page 71



## JP-MBF lightning protection system (J.P. utility patent) for antennas and roof installations

ISO air termination system for complex roof installations

- Benefits:**
- Reduces the separation distance "s".
  - Standardized (down conductor 50 mm<sup>2</sup>).
  - Optically unobtrusive.
  - Cut to the right length on site.
  - Installation is necessary only in the area where the separation distance is not kept.
  - Easy-to-assemble.
  - Insulated specification.
  - Reasonably priced solution.





2005

## Concrete base with J.Pröpster wedge technology

(J.P. patent)

- Benefits:**
- Fit of the air termination rod adjustable to the roof.
  - High quality: wedge + clamp completely of stainless steel V2A.
  - Wedge with integrated double connection clamp

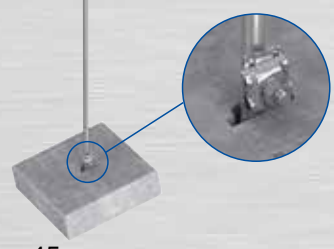

Roof pitch compensation:

Page 45

## Telescopic insulated stand-off with tape clamp

- Benefits:**
- Infinitely adjustable.
  - Heavy-duty specification (GRP  $\varnothing$  40/32 mm).
  - For free carrying of air termination rods.



Page 140

## Surge arrester for photovoltaic systems with integrated decoupling coil

- Benefits:**
- Specially designed for the use in the DC side of photovoltaic systems.
  - Fault resistant Y circuit.
  - Energetic coordination to a surge protective device integrated in the inverter without additional conductor length.



2006

## Touch voltages protection measures for lightning protection systems

For protection against dangerous touch voltages, also with integrated disconnecting clamp.



Page 146

## J.Pröpster CC Clamp system

For terminals and connections  $\varnothing$  8-10 /  $\varnothing$  16 mm with clamps, pipe clamps or steel constructions.

- Benefits:**
- Clamping system for round conductors  $\varnothing$  8-10 /  $\varnothing$  16 mm.
  - Variable fixing lengths by easy swap of the hexagonal bolt M10.
  - Ex area (zone 2/22): The clamp (EN 63305-3 Bbl. 2) is protected against self-loosening.
  - - 100 kA tested -

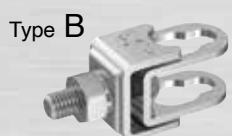

- Type A:** Connection of air termination rods or earth lead-in rods  $\varnothing$  16 mm to clamps, pipe clamps or steel constructions.
- Type B:** Connection of rods  $\varnothing$  16 mm and conductors  $\varnothing$  8-10 mm to clamps, pipe clamps or steel constructions.
- Type C:** Connection and disconnection clamp  $\varnothing$  8-10 /  $\varnothing$  16 mm - also suitable for cable connections.

Page 90



## 2007 Roof conductor holder for RIB-Roof 500 System (J&P patent)

The reasonably priced solution for installing round conductors to RIB-Roof 500 system.



Page 77

## Connection clamp for earth rods

Connection of strips 30 x 3.5 mm, round conductors  $\varnothing$  10 mm and earth rods  $\varnothing$  25 mm.



Page 119

## 2008 Connection clamp (J&P utility patent)

For different combinations  $\varnothing$  6-20 mm and flat 30 x 3.5 mm or  $\varnothing$  10 mm; with M10 clamping screw.

- Benefits:**
- Maximum contact security through consistent contact pressure.
  - Shorter and easier installation - only 1 screw M10.
  - Universal usage and lightning current carrying capable connection - reinforcement irons and earthing conductors are positioned in the part by the guide beading and are connected with just one clamping screw.



Page 117



fl. 30 x 3.5 /  $\varnothing$  10 mm



$\varnothing$  16 /  $\varnothing$  10 mm

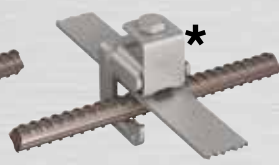

$\varnothing$  16 / fl. 30 x 3.5 mm



fl. 30 x 3.5 / fl. 30 x 3.5 mm



fl. 30 x 3.5 /  $\varnothing$  10 mm

\* Connection also possible without clamping bracket.

## 2009 Air termination rod system for all common types of roof tiles

Infinitely adjustable, to fit any tile

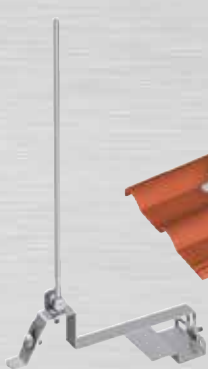

Page 47

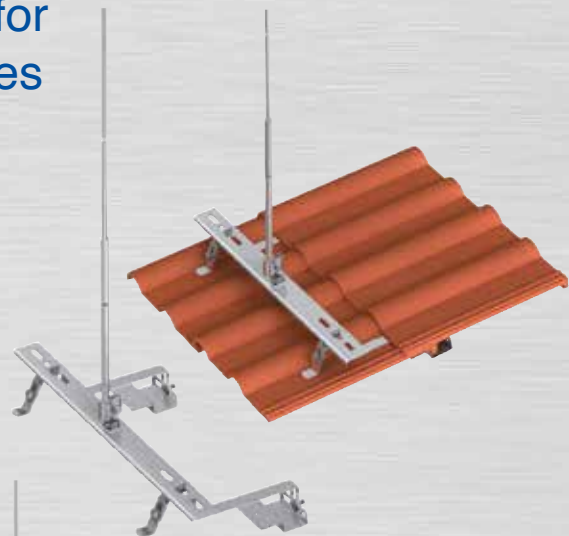
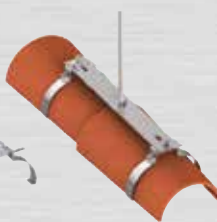



## 2009 Clamping piece



Page 110

Suitable for the use of round conductors  $\varnothing$  10 mm as spacers for the installation of foundation earth electrodes flat 30 x 3.5 mm on end or round  $\varnothing$  10 mm.

**Benefit:** • Infinitely adjustable height for different foundations (soil, sand, mineral concrete) or blinding layer.

Distance pins have to be installed by the customer.

Distance pin: reinforcement iron  $\varnothing$  10 mm or wire  $\varnothing$  10 mm

Blinding layer of concrete



Strip 30 x 3.5 mm or round wire  $\varnothing$  10 mm

## Fixing system for insulated stand-offs **16plus+**

Light-weight type for the fixation of air termination rods with additional concrete base.



Page 142-144

Individual combinations:

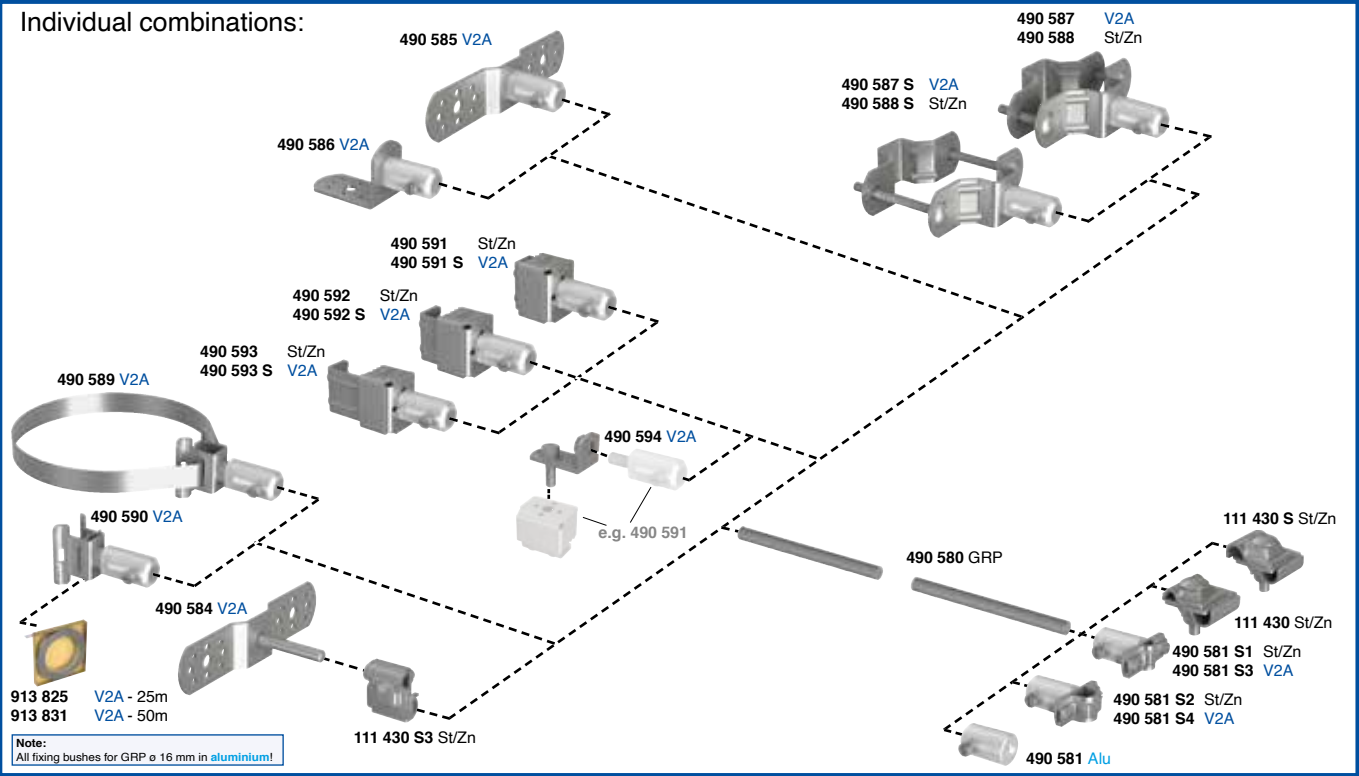



## 2010 Air termination rod system (J.P. utility patent) for metal / tin roofs

with magnetic plate (also for a roof pitch up to 10°).

Air termination rod system with fixing cross, base with magnetic plate and KS-connector.

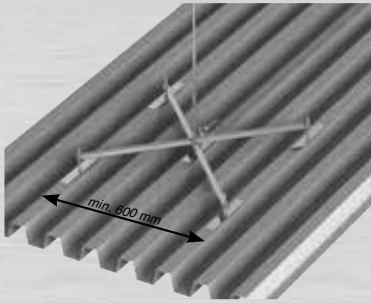

Page 49

## 2011 Conductor fastener for metal / tin roofs

Made of stainless steel V2A with magnetic plate and Niro-Clip V2A for ø 8 mm loose conductor leading inclusive plate V2A 180x40x3 mm, or type with spacer to raise the height of the conductor leading to 80 mm.

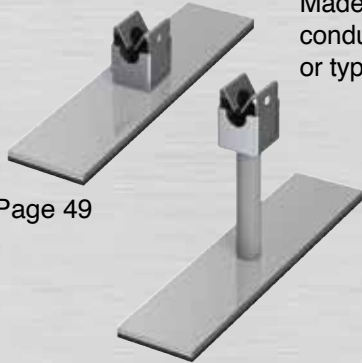

Page 49

A change of colour for all our surge protection devices from red to blue, our company colour

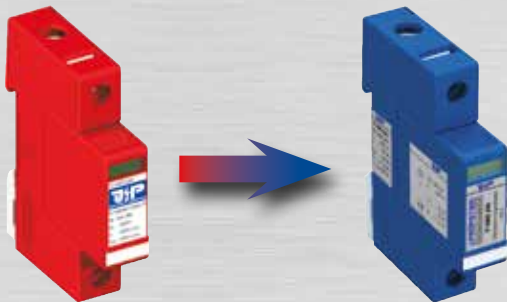

## Prö Cu/Al-wire - round wire made of bimetal-composite Cu/Al

The aluminium core is crimped with the copper coating. In this way both materials are bonded together to be non-corrosive.

- Benefits:**
- Cost saving - good price-performance ratio.
  - Lower price fluctuation due to less copper content.
  - Torsionable - can be worked like soft wires.
  - Non-corrosive connection between aluminium and copper.
  - No problems with corrosion at the cut surface, because of the surface ratio of copper and aluminium.
  - In conformance with standards.



Page 39



## 2012 Niro-Clip conductor fastener - high version



Height of conductor leading: 36 mm.  
Conductor fastener for fixing round conductors to roofs and walls.  
Snap mechanism and base made of metal.



Page 65 ff.

## System Vario-clamp - M8-Plus (J+P patent) with cylindrical collar



The **system Vario-clamp M8-Plus** is a reasonably priced, practical solution for connecting differently shaped conductors.

**Benefit:** • The cylindrical, patented collar on the top part, considerably improves assembly.



ø 8-10/8-10 mm



ø 8-10/16 mm



ø 8-10/30x3.5 mm  
ø 8-10/40x4 mm



30x3.5/30x3.5 mm  
40x4/40x4 mm



System Bimetal  
ø 8-10/30x3.5 mm

Page 97

## Surge protective devices - mains systems type 1+2 and type 2

- Benefits:**
- Safe plug-in fixation and contacting due to module locking mechanism.
  - **P-HMS 280 R** with 12.5 kA (10/350  $\mu$ s) per pole and 50 kA (10/350  $\mu$ s) 4-pole.
  - **P-HMS 280 max** with 25 kA (10/350  $\mu$ s) per pole and 100 kA (10/350  $\mu$ s) 4-pole.
  - Optimum price-performance ratio.
  - High backup fuse values.



P-HMS 280 Fm *max*



P-HMS 280 Fm R 4



P-HMS 280 *max* 3+1



P-HMS 280 R 3

Page 178 ff.

## Surge protective devices - photovoltaic systems type 1+2 and type 2

- Benefits:**
- Safe plug-in fixation and contacting due to module locking mechanism.
  - Type 1+2 with 12.5 kA (10/350  $\mu$ s) per pole.
  - Optimal price-performance ratio.



P-HYS 605 Fm R PV



P-VYS 605 Fm R PV



P-HYS 805 R PV



P-VYS 1005 R PV

Page 186 ff.



## 2013 Fixed earthing terminal with foam cover

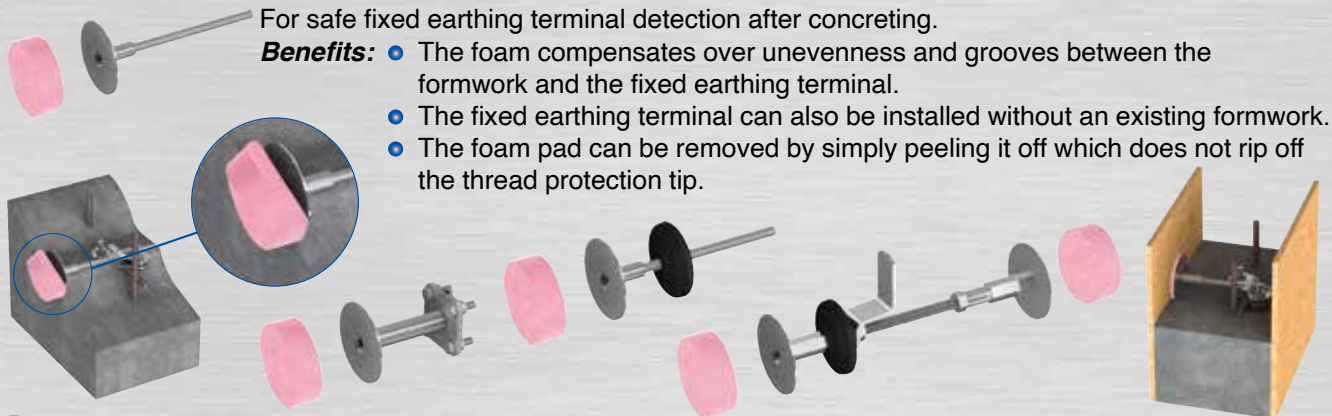

For safe fixed earthing terminal detection after concreting.

- Benefits:**
- The foam compensates over unevenness and grooves between the formwork and the fixed earthing terminal.
  - The fixed earthing terminal can also be installed without an existing formwork.
  - The foam pad can be removed by simply peeling it off which does not rip off the thread protection tip.

Page 123

## Protective cap for earthing conductors



For injury prevention and for marking during the construction stage.

- Benefits:**
- Distinct marking of the earth lead-in terminal lug during the construction stage (requirement according to DIN 18014).
  - Injury prevention.
  - For  $\varnothing$  10 mm or flat 30 x 3.5 mm.
  - Easy and fast fitting on conductor ends.
  - Cost-effectivel, reusable, safe.

Page 38

## $k_C$ -clamp (J.P. patent)



Connection-clamp to reduce the  $k_C$  value to the factor 0.25 by splitting up the lightning current flowing through the air-termination rod onto 4 down conductors.

- Benefits:**
- All connection types (cross-, T-, corner-, parallel-, end to end connection) and additional connection to an air-termination rod or tip with only one clamp are possible.
  - A connection for crossing points of the conductor routing with an air-termination tip is also possible without a concrete base.
  - The  $k_C$ -clamp easily reduces the  $k_C$  value by a factor 0.25 by splitting up the lightning current flow.
  - The  $k_C$ -clamp is also useable in already installed systems.

Page 46

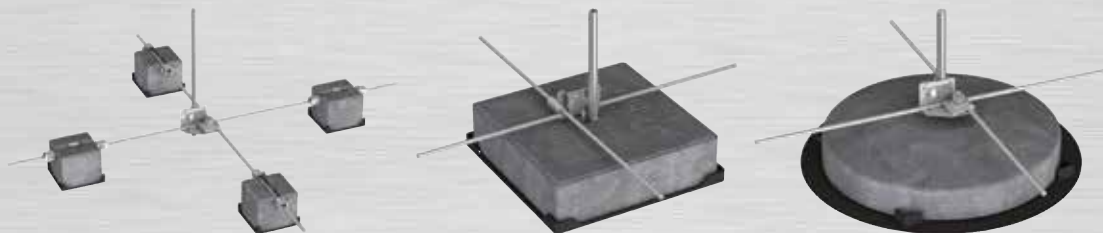

## Support tool for concrete base with wedge

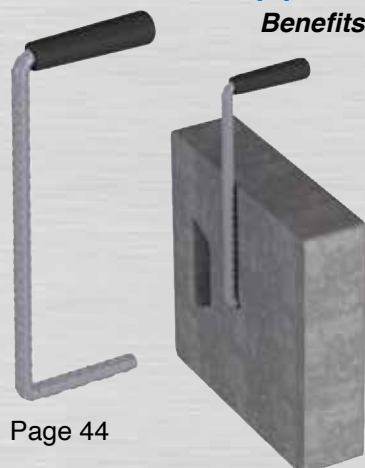

- Benefits:**
- Even ergonomic weight shift.
  - Easy and quick placement of the concrete bases – reduction of undesired motion processes which may cause back, shoulder or neck problems.
  - No abraded finger skin or work gloves.
  - Comfortable transportation with soft carry handles, also suitable for longer distances.

Page 44







## Quick connectors



To connect reinforcements and round conductors  $\varnothing$  6-10 mm /  $\varnothing$  10 mm

- Benefits:**
- Easy and simple installation – only one clamp bolt M10.
  - T-, joint, cross and parallel connections possible.
  - Easy handling of parallel connections along the line run due to fixed guide lugs.

Page 116

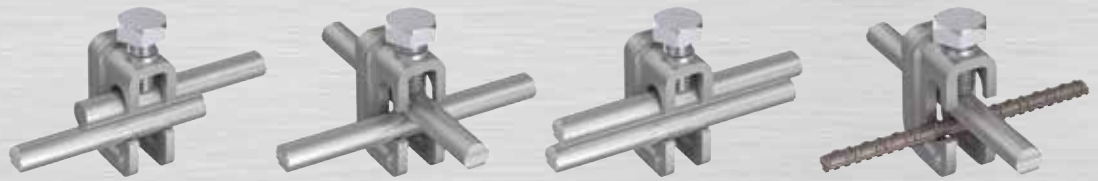

## Protection measures against step voltages

e.g. in shelters by means of interlinked grid bar mats. According to German VDE/ABB brochure „Blitzschutz von Schutzhütten“.

- Benefits:**
- Potential control with mesh size of grid bar mats 250 mm x 250 mm.
  - Grid bar diameter: 4mm.
  - Manufactured completely of stainless steel V4A.

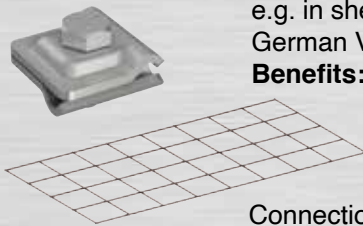

Connection example:

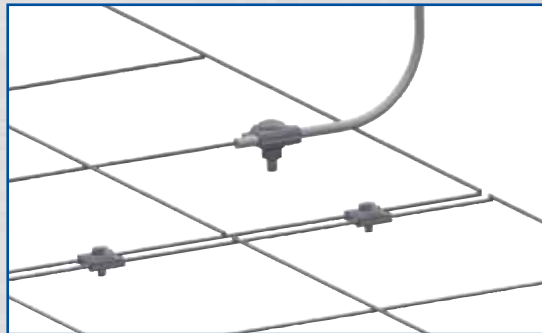

Page 110

## 2014 ES reinforcement clamp



to connect flat and round conductors to the reinforcement steel

- Benefits:**
- Just one screw M10.
  - Longitudinal, cross and diagonal connections are possible.
  - The clamping area can be changed by simply rehanging the clamp bottom part to the top part.

Page 118



## Parallel saddle clamp



special clamp to install the conductor alongside the joint, snow load protected. Clamping range up to 4 mm.

- Benefits:**
- Simple and quick installation.
  - Secure clamp positioning on the joint.
  - Significantly better installation by patented cylindrical attachment.

Page 100





## 2014 Multi-flat/round connecting clamp

for a fast and simple connection of tapes with the reinforcement

- Benefits:**
- No loose components during the installation.
  - Low construction height after the installation.
  - All occurring connection types are possible such as T-, cross, parallel and diagonal connection.
  - Different cross sections can be used, e.g. flat 30x3.5 mm und  $\varnothing$  5 - 25 mm.
  - Only one screw M10 = central contact pressure.
  - Optimal economic use for planning, storekeeping, calculation and invoicing.



Page 114



round/flat cross connection



round/flat diagonal connection



round/flat + round parallel connection



round/flat + round cross connection

## Connection set for safety rope systems

to connect safety rope system on roofs with the lightning protection system.

- Benefits:**
- No negative impact of the PSA rope glider when passing the rope contacts.
  - Length compensation between the lightning protection system and the rope protection system in case of fall loads.
  - Lightning current protected connection to the existing external lightning protection system.



Page 106

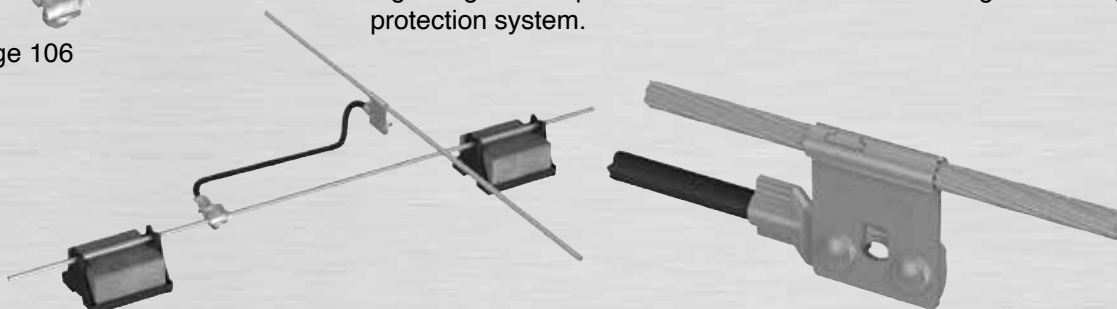

## Connection clamp

for fast and simple connection of grounders to the reinforcement.

- Benefits:**
- Easier installation than with conventional diagonal clamps due to swivelling opening in the top of the clamp.
  - No clamp dismantling necessary.
  - Large clamping range flat/round ( $\varnothing$  10 / fl. 40 mm) compatible with the reinforcement ( $\varnothing$  6 - 40 mm).
  - T-, cross, parallel, and diagonal connections are possible.



Page 113





2014

## Disconnection clamp with terminal angle

Two versions, for clamps  $\varnothing$  8-10 mm or flat 30 mm

- Benefits:**
- Optimized tight fit with the open-end wrench due to the patented cylindrical part of the Vario-clamp top part.
  - Universal use e.g. installation with a connecting terminal to a T-carrier or direct installation on a fixed earthing terminal.
  - Cost-efficient solution – terminal angle and disconnection point in one component.



Page 95



## Factory expansion (45,000 sqm) in Deining



Three kilometres to the south of the main factory, the new warehouse is built with 4,000 sqm on a site of 45,000 sqm.



2015

## Equipotential bonding bar with metal cover (J&P utility patent)

- Benefits:**
- Each clamping screw is protected against self-loosening trough a spring ring (according to EN 60079-14).
  - Connection is possible from the top and the bottom.
  - Clamps cannot be lost the way they are installed and can be individually removed.
  - Break-proof aluminium cover - sealable.
  - Low construction height.
  - Clearly marking of the individual clamping positions on the busbar.
  - Easy installation – only two screws for fastening.



Page 132

## Air termination pole base frame with a 2-part base frame

- Benefits:**
- Small space requirement during storage and inside the transport vehicle.
  - Easy transport in lifts, staircases and through roof openings.

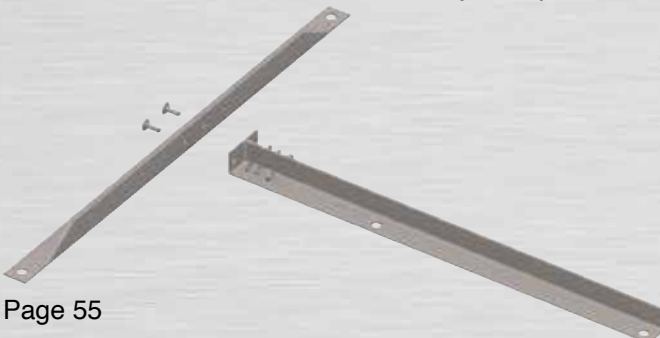

Page 55





## 2015 SPD product range - MOV + GDT type 1+2



- Benefits:**
- Leakage-current free due to series connection of gas discharge tube & varistor.
  - Safe fixation and contact ensured by module locking mechanism.
  - P-HMS 280 G having 12.5 kA (10/350  $\mu$ s) /pole and 50 kA (10/350  $\mu$ s) 4-pole.
  - Optimal price/performance ratio.
  - Max. backup fuse 160 A gL/gG.
  - Min. cross section for connection 4 mm<sup>2</sup>

**Note:** MOV = Metal-oxide varistor  
GDT = Gas discharge tube

Page 180



P-HMS 280 Fm G 3



P-HMS 280 Fm G 1+1



P-HMS 280 G 2



P-HMS 280 G 3+1



## Surge arrester P-LED 230 type 2+3

- Benefits:**
- SPD type 2+3-arrester in a compact design.
  - Specially designed for the protection of LED applications.
  - Visual function display.
  - Optimal price/performance ratio.

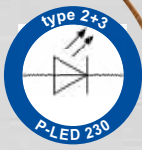

Page 184



## Adjustable test joint box

for flush mounting on facades with thermal insulation composite systems.

- Benefits:**
- Flexible for use in facades with thermal insulation composite systems.
    - Installation depth of 90-140 mm (Ord. no. 111 585):  
Depth can be adjusted trough a simple clamping technique.
    - Installation depth of 130-320 mm (Ord. no. 111 587; 111 588):  
Cutting of the spacer by attached markings.
  - No heat bridge due to integrated insulation.
  - The insulating stainless-steel cover V2A complies with protection class IP65.
  - Easy measurement of the ground circuit resistance with earth test tongs.
  - Installation is facilitated by plasterwork covering.



Page 108

## Further factory expansion in Deining



Another newly constructed production hall in plant III in Deining with a space of 4,000 sqm





2016

## Connection clamp with clamping bracket and spring



Page 117

- Benefits:**
- Maximal contact safety with regular contact pressure
  - Reduced and simplified installation:
    - Only one screw M10.
    - Spring keeps strap up during the installation.
  - Universal use.
  - The reinforcement and ground conductors are positioned in the component by guiding corrugations and connected with just one clamping bolt capable of carrying lightning current.



## Mounting aid for connection clamps



Page 175

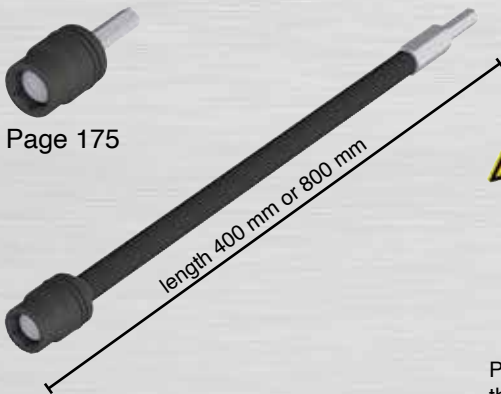

Position mounting aid with the magnetic side of the socket wrench on the hexagonal screw of the connecting clamp.

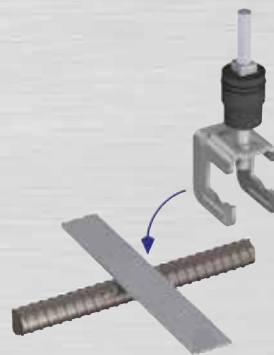

Position the clamp on the desired installation place.

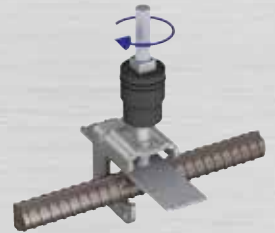

Tighten the positioned clamp until the required torque is reached. (you can also use a cordless screwdriver)

## Manual straightening tool – light & heavy version



### Light version:

Made of forged steel – chromed surface, hardened straightening bolt. Optimal straightening geometry for quick alignment and bending of round wires.



### Heavy version:

Consisting of a stainless steel V2A pipe, PVC handle and a swivelling straightening head made of hardened steel with 3 attached straightening bolts and a tooth slot. The straightening head can be optimally adjusted to the respective work situation with 9 steps.

Page 173

Utilization example:





## 2016 Heavy connecting – disconnecting clamp (J&P patent)



Page 101

for separators  $\varnothing$  8-10 mm or flat 30 mm

- Benefits:**
- Better form fit with socket wrench due to the patented cylindrical form of the Vario-clamp top.
  - For safe-contact connection of round conductors or strips with steel constructions with a material thickness up to 52 mm.
  - Cost-efficient solution - connecting bracket and test point in one component.

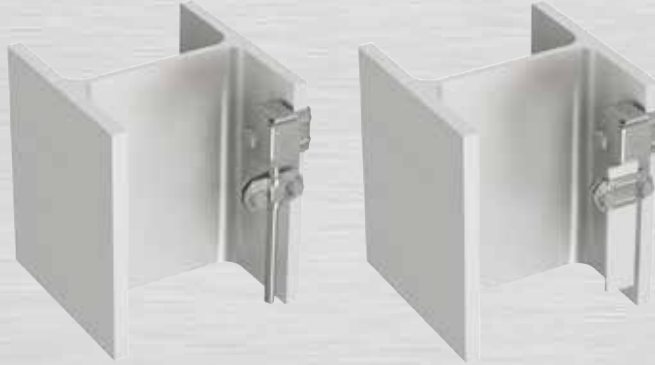

## Multi-Mini saddle clamp



Page 99

to connect conductors with joints, metal sheets or profiles (e.g. PV frame etc.)

- Benefits:**
- To connect conductors with metal sheets and profiles up to 8 mm.
  - For conductors 6 - 50 mm<sup>2</sup> ( $\varnothing$  2.8 -  $\varnothing$  8 mm).
  - Longitudinal and cross conductor connection is possible.
  - Can also be used for potential equalization applications.



Page 99

## Attic saddle clamp

to connect the down conductor with the attic sheet without damaging the drip edge.

- Benefits:**
- Connecting clamp for secure contacting of an attic sheet.
  - Simple installation.
  - No damaging or flattening of the drip edge.
  - Especially useful if the clamp has to be repositioned again.



## Multi-Quattro connecting and terminal clamp



Page 91

- Benefits:**
- Just one clamp for all connections.
  - Reduced and simplified installation – only one screw M10.
  - For the connection of 2 - 4 wires  $\varnothing$  8 mm.



Page 88

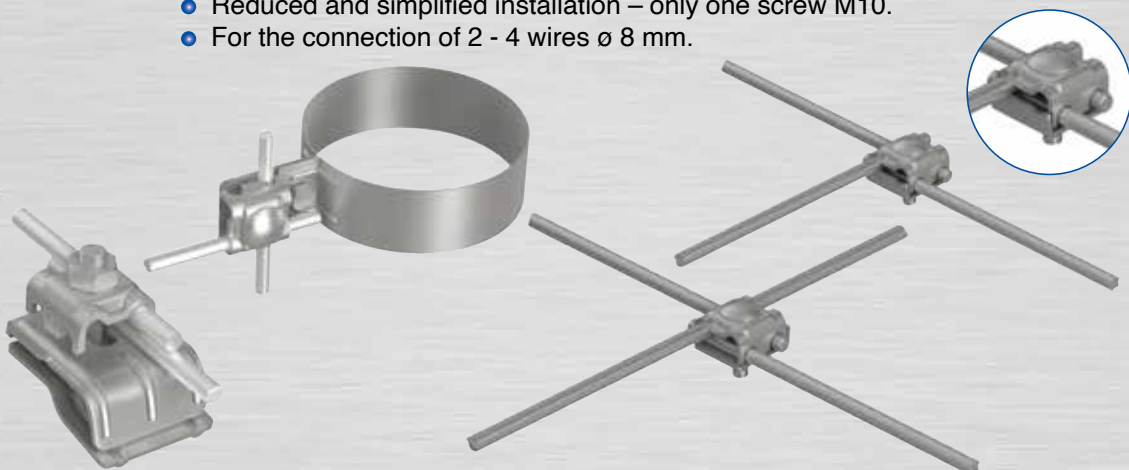



2016

## Roof inclination adjustment of base frames for roof inclinations up to 10°

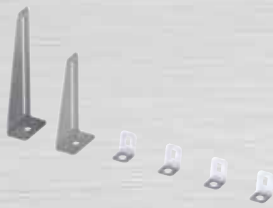

Page 55

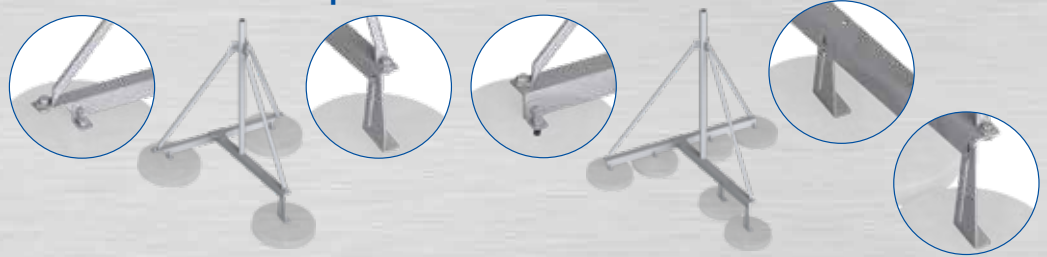

## Telescopic air termination pole, freestanding, aluminium, with adjustable base frame for roof inclinations up to 10° (JPR utility patent)

- Benefits:**
- Less space required for storage and in transport vehicle (transport / delivery length ca. 2 m).
  - Adjustment of roof inclination up to max. 10°.
  - Easy transport in lifts, staircases and through roof openings.
  - Shorter and easier assembly of the air termination pole with self-locking set screws M8 or M10.
  - Pole heights in the SET adjustable up to 4.35 m, 5.5 m, 6.5 m & 8.0 m.
  - Statically calculated according to Eurocode (EC).

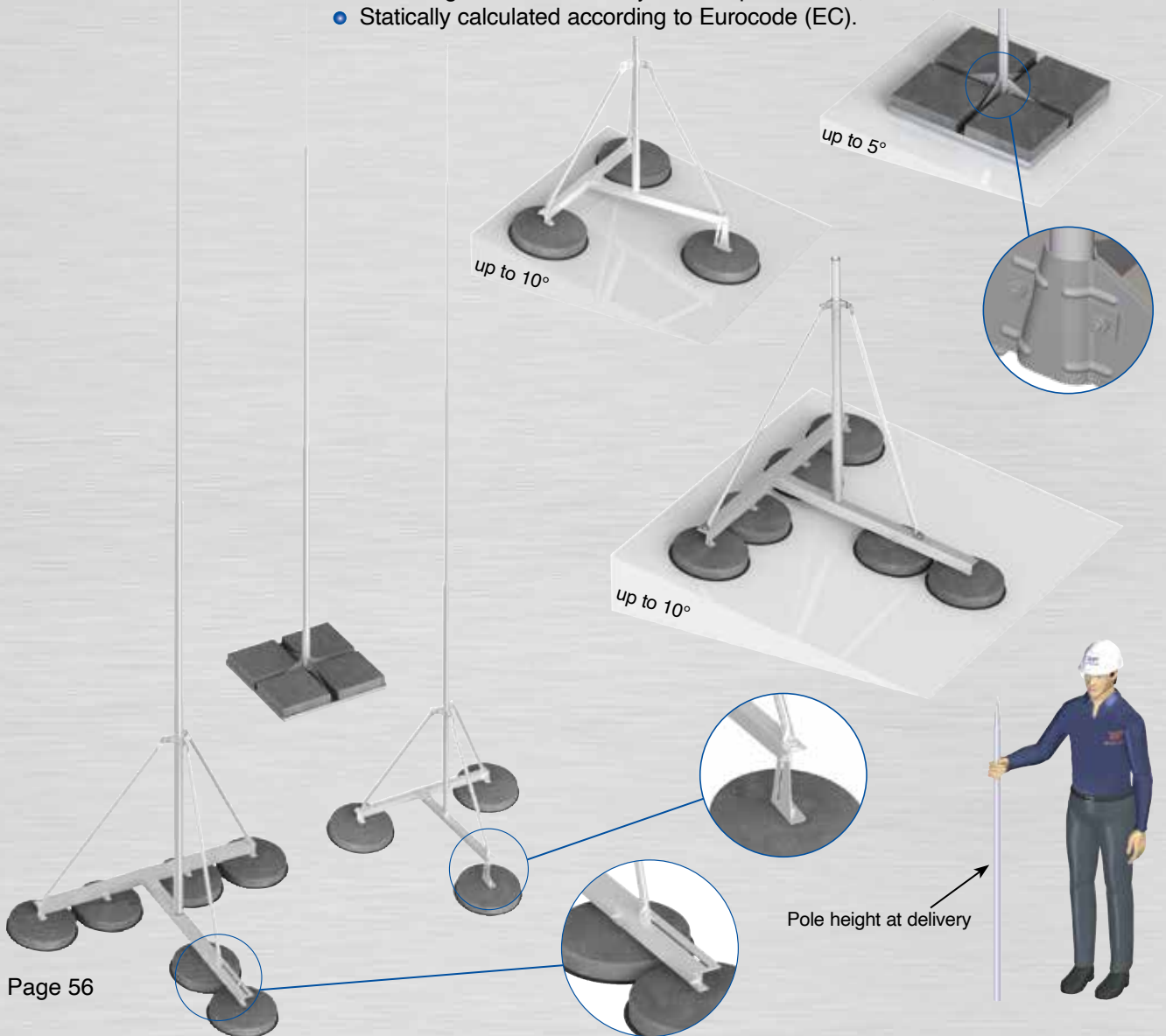

Page 56



2016

## Diagonal swiveling cross connecting clamp

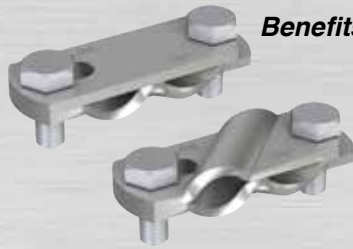

- Benefits:**
- No dismantling of the clamp is necessary.
  - Easier installation than with conventional diagonal clamps because the clamp top has a swivelling opening.
  - Low construction height after the installation.
  - Two hexagon screws M10 (wrench size 17)
  - T-, cross, parallel and diagonal connections are possible.



Page 113



P-1 SQ 5 HF

## Surge arrester for high-frequency signal circuits

Surge arrester (2-pole) for measurement and control technology. Surge protective device according to EN 61643-21, designed as coarse and fine protection for high-frequency, earth-potential free signal circuits.

Page 192

## Air termination rod made of stainless steel / aluminium with stainless-steel angular frame for 2 or 3 concrete bases



- Benefits:**
- Only small space necessary
  - Low roof loads
  - Easy and quick installation

Page 51

## New fixed earthing terminal system



New fixed earthing terminals and wall bushings, especially for high 50 Hz current rating according to EN 50522

Page 123

## Multi-Plus saddle clamp

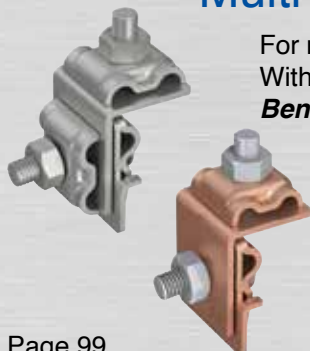

For metal sheet connections lengthwise and crosswise conductor leading. With angle and one or two double connecting clamps. Clamping range up to 8 mm.

- Benefits:**
- Conductor leading is possible in lengthwise and crosswise direction above the standing seam.
  - 10 cm<sup>2</sup> contact surface on standing seam or sheet

Page 99





2016

## Quick connector for reinforcements up to $\varnothing$ 16 mm



to connect reinforcements and round conductors  $\varnothing$  6-16 mm /  $\varnothing$  10 mm.  
**Benefits:**

- Quick and easy assembly – just one clamping screw M10.
- T and cross connections are possible.

Page 116

## Connecting clamp - small



For various combinations. With clamping screw M10.

- Benefits:**
- Cost-efficient solution for connecting flat conductors with small reinforcement rods.
  - Compact design.
  - Only one clamping screw M10.

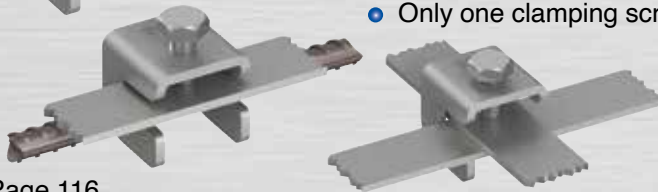

Page 116

## Multi-flat/round connecting clamp

Now available also with countersunk screw and carriage bolt.

For a quick and easy connection of ground conductors with the reinforcement.

**Additional benefits:**

**Benefit of the countersunk allen screw:**

- Extremely low design for a small concrete cover.

**Benefit of the carriage bolt:**

- Quick component installation.

**Benefit of the turned carriage bolt:**

- Facilitates the laying of the ground conductor underneath the reinforcement.



Page 114

## Air termination rod holder for ridge tiles, acc. to EN 62561-2

- Benefits:**
- Large clamping range for ridge tiles of 150-300 mm width.
  - Quick and easy toolfree preadjustment of the desired clamping range by means of two symmetrical clamping bracket with self-retaining locking catches.
  - Direct connection option capable of carrying lightning current of the ridge/down conductor on the air termination rod holder.

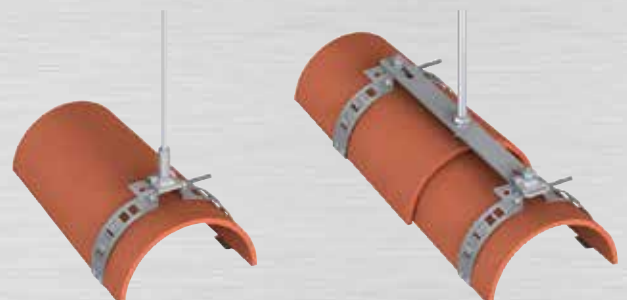
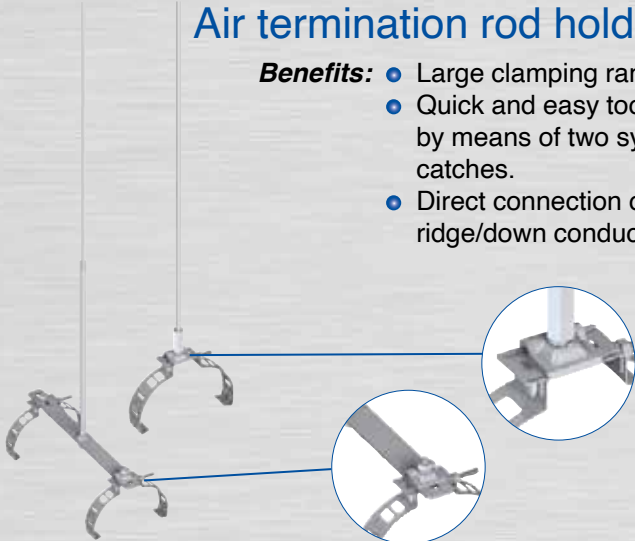

Page 47



2017

**HVC-protected**

## - High voltage resistant conductor HVC-85 conductor

Page 154 ff.

- Benefits:**
- Significantly reduced installation work and time.
  - The required equipotential bonding is provided by the integrated shield braid in the conductor – no separate conductor is needed.
  - Mechanical and chemical protection by light grey, UV-resistant protective jacket.
  - Equivalent separation distance “s” = **0.85 m** in air.
  - No additional separation distances must be observed in the base area.

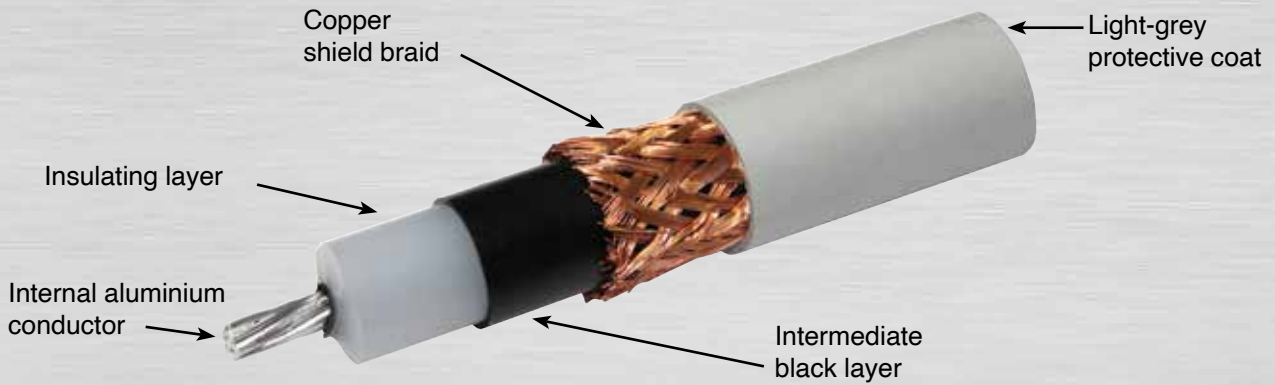



## Conductor fastener and air termination poles for HVC-85 conductor

Page 156 ff.

Introduction of a complete product series for fixing **HVC-85** conductor.

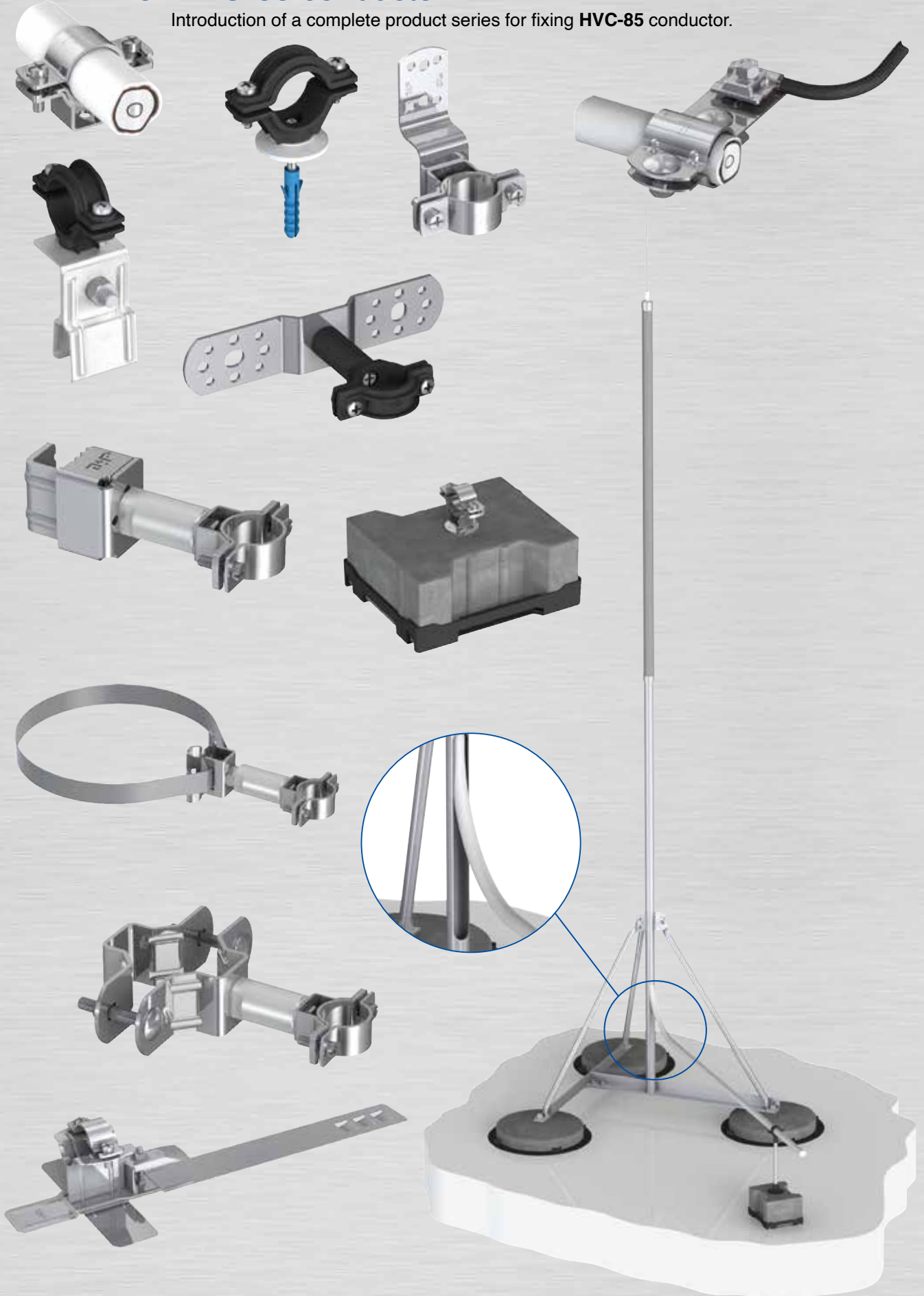



## 2017 Further factory expansion in Deining



Another newly constructed production hall in plant III in Deining with a space of 4,000 sqm



### Multi-Max reinforcement clamp 75 x 75 mm

for the connection of earth conductors with reinforcement.

- Benefits:**
- No loose components during installation.
  - Only one screw M12 = central contact pressure.
  - All existing connection types such as T-, cross-, parallel- and diagonal- connection are possible.
  - Various diameters from  $\varnothing$  8 mm to  $\varnothing$  32 mm are possible.



Page 115

### Multi-Max reinforcement clamp 50 x 50 mm

for the connection of earth conductors with reinforcement.

Available in different versions.

- Benefits:**
- No loose components during installation.
  - Only one screw M10 = central contact pressure.
  - All existing connection types such as T-, cross-, parallel- and diagonal- connection are possible.
  - Suitable for conductors flat 30x3.5 mm or  $\varnothing$  10 mm.
  - Low construction height.



Page 115



**Additional benefit of a carriage bolt:**

- Fast component installation.

**Additional benefit of a turned carriage screw:**

- Installation of conductor underneath reinforcement is possible.



**Additional benefit of a threaded bolt:**

- Assembly possible in two steps:
  1. Connect the foundation earth electrode (round) to the reinforcement
  2. Connect and fix the fixed earthing terminal to the reinforcement

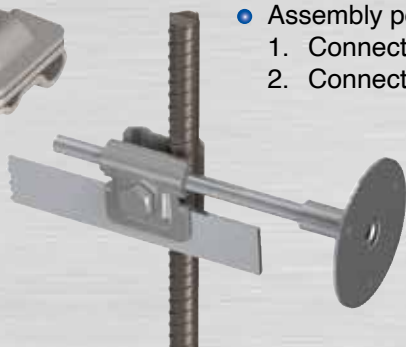



2018

## Air-termination rod-SET insulated GRP/stainless steel/aluminium with angle-base frame stainless steel for concrete base



- Benefits:**
- Small footprint.
  - Up to 0.9m insulated length.
  - Low roof loads.
  - Easy and quick installation.

Page 139

## RS-Telescopic-air-termination-pole insulated, freestanding including air-termination pole base frame with inclination adjustment up to 5°

(J.P.-utility patent)

- Benefits:**
- Less space required for storage and in transport vehicle **(transport / delivery length ca. 2.2 m).**
  - Adjustment of roof inclination up to max. 5° (with additional roof inclination adjustment up to 10°).
  - Easy transport in lifts, staircases and through roof openings.
  - Shorter and easier assembly of the air termination pole with self-locking set screws M8.
  - Pole height in the SET adjustable up to 4.35m.
  - Up to 1.7m insulated length.
  - Statically calculated according to Eurocode (EC).

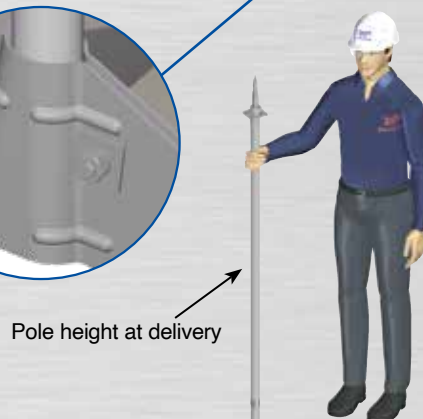
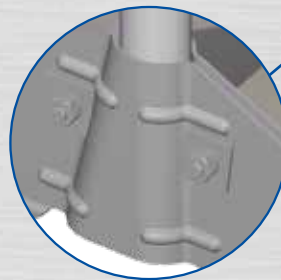
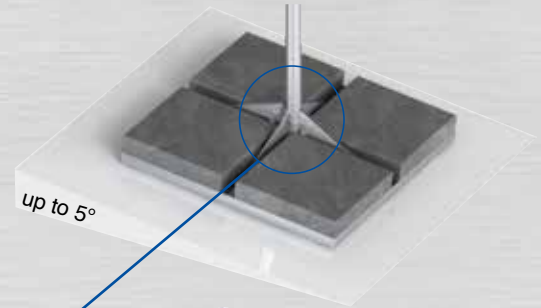
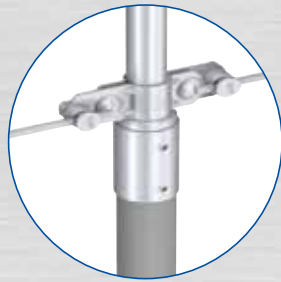

Page 139



## 2019 Combined arrester P-HF BOX



Page 195

for the protection of telephone and Internet connections

- Benefits:**
- Compact design
  - Quick and easy installation by surface-mounted box
  - Protection class IP 65
  - Universally usable surge arrester for different telecommunication interfaces, such as VoIP.
  - Cut-off frequency up to 250 MHz
  - Push-In terminal block for fast connection without tools (simple, push-in terminations of solid and ferruled conductors)
  - High discharge capacity up to 2.5 kA (10/350  $\mu$ s) per line

## Connecting clamp for flat 40 mm with or without clamping bracket and compression spring

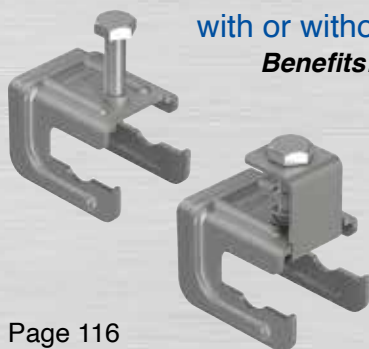

Page 116

- Benefits:**
- Clamp especially for the use with flat strip 40mm.
  - Maximum contact reliability through uniform contact pressure.
  - Shortened and simplified assembly - only one M10 screw.
  - Simplified installation due to design with bracket and spring



## Terminal clamp "Perfect" heavy-duty type



Page 101

with two clamping jaws for the variable connection of round conductors to steel constructions - horizontal and vertical in every direction (360°) possible.  
**Also suitable for connecting flat strip to the fixed earthing terminal**

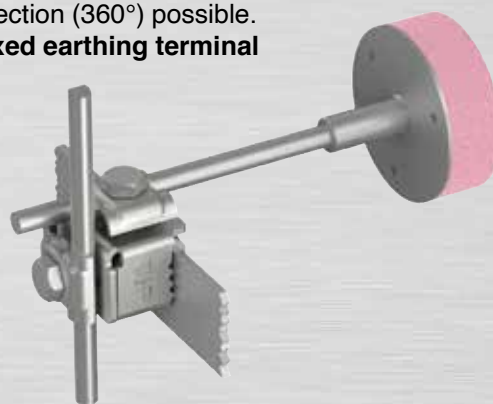

## Smart connector for earth rod



Page 119

for the connection of round or flat conductors with the earth rod.

- Benefits:**
- Installation-friendly mount function - no threading necessary.
  - Maximum contact safety through even contact pressure.
  - Quick and easy installation – only one screw M10.





## - High voltage resistant conductor HVC-50 conductor

Page 150 ff.

- Benefits:**
- Significantly reduced installation work and time.
  - The required equipotential bonding is provided by the integrated shield braid in the conductor – no separate conductor is needed.
  - Mechanical and chemical protection by light grey, UV-resistant protective jacket.
  - Equivalent separation distance “s” = **0.50 m** in air.
  - No additional separation distances must be observed in the base area.

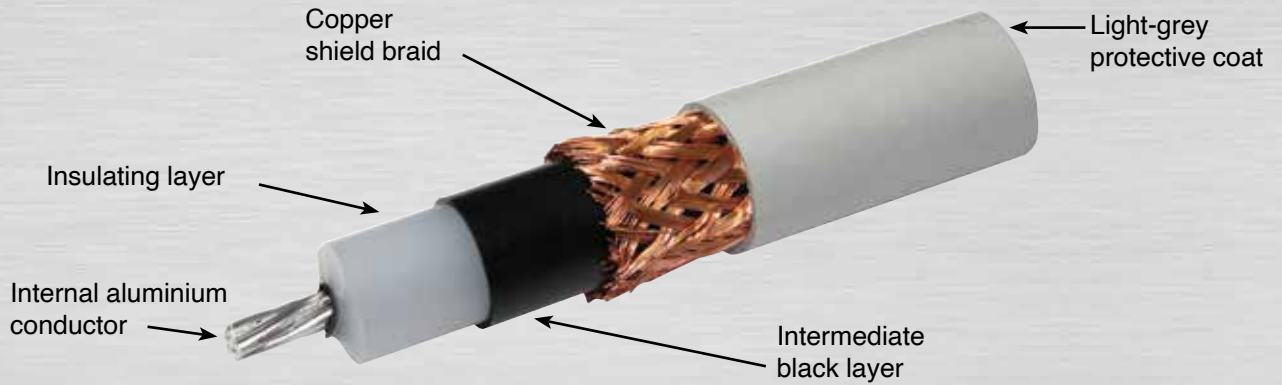

## Conductor fastener and air termination poles for HVC-50 conductor

Introduction of a complete product series for fixing **HVC-50** conductor.



Page 156 ff.

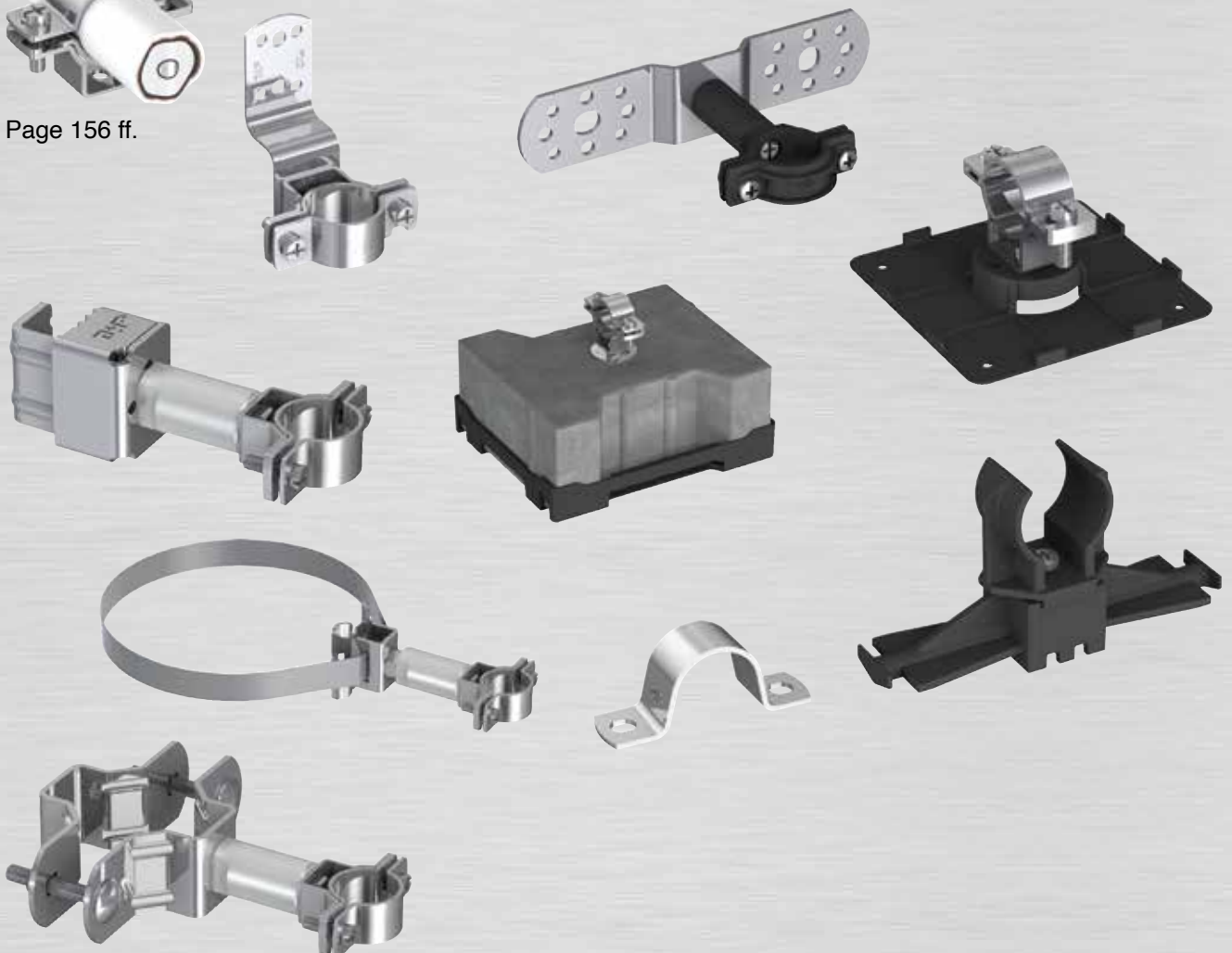



2020

## HVC-protected - Beam clip for HVC-50 and HVC-85

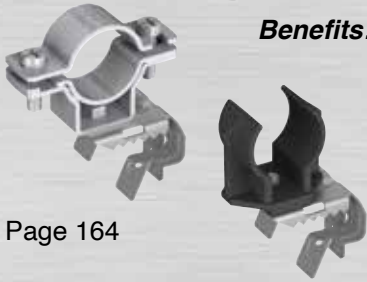

- Benefits:**
- Discreet and space-saving conductor routing of the HVC-conductor on the inner sides of steel beams or profiles.
  - Easy and quick installation by putting the clip on the beam.
  - Ideal for the installation of the HVC-conductor on steel structures.
  - Conductor holder for the loose and fixed conductor leading.

Page 164

## Saddle clamp "Flex"



for secure connection to sheet and steel construction

- Benefits:**
- Installation of the clamp on the seam with just one screw M8.
  - Safe fixation on the seam because of serrated design of fastening part.
  - Also suitable for the equipotential bonding of facade substructures.

Page 98

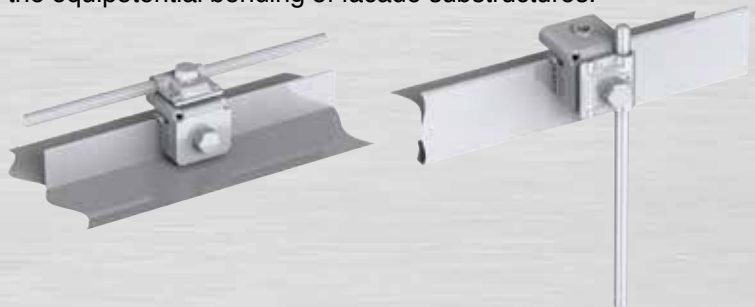

## PV-connector



for equipotential bonding

- Benefits:**
- Easy assembly without damaging the mounting rail when clamping.
  - Quick installation – only one hexagon nut M8.
  - Subsequent installation possible by simply swiveling the hammer head screw into the mounting rail groove.
  - PV-connector „Flex“, suitable for various conductor materials corrosion-proof connection through contact plate made of stainless steel

Page 100

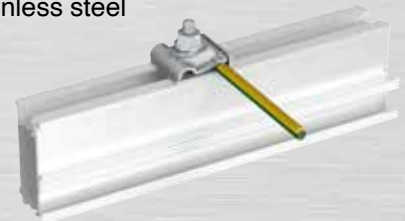

## Further factory expansion in Deining



Another newly constructed production hall in plant III in Deining with a space of 4,000 sqm







## 2020 **HVC-protected** - Conductor fastener for exterior air termination installation of the HVC-conductor



- Benefits:**
- Fixing the position of the HVC-conductor by exterior air termination installations in the area of the insulated support.
  - Easy and quick installation by fixing with calbe tie.



Page 167

## 2021 Surge arrester type 2+3 P-VM 280 *slim*

multipole / mains system compliant



Page 183

- Benefits:**
- Narrow dimensions of only 2 mods.
  - Compact design facilitates retrofitting in existing electrical plants.
  - Push-In terminal block for fast connection without tools.
  - Combined medium and fine protection type 2+3.
  - Ideal surge protection for industrial terminal devices with three-phase connection.
  - Min. cross section for connection 0.5 mm<sup>2</sup>.
  - Standard-compliant, economic surge protection solution e.g. for residential and office buildings.
  - Optimal price/performance ratio.

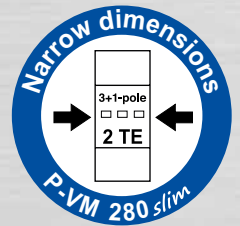

## **HVC-protected** - Roof conductor holder for standing seam roofs

for mounting the HVC-conductor on the standing seam.

- Benefits:**
- Installation of the clamp on the standing seam with only one screw M8.
  - Secure positioning on the standing seam due to the prongs

## Roof conductor holder for interlocking tiles



Page 76

for hooking into interlocking tiles with a wide rebate or less opportunity to list the roof tile.

## Connection clamp max



Page 117

for different combinations  $\varnothing$  25-38 mm and flat 30 mm / flat 40 mm or  $\varnothing$  10 mm

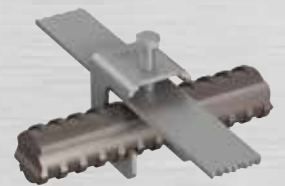

Page 95

## Disconnecting clamp

for the fast and easy opening of the connection down conductor – earth entry with fixed conductor ends.

- Benefit:**
- Conductor ends stay fixed when opening the disconnecting clamp due to the insulated connection.



## Air termination pole with flange plate

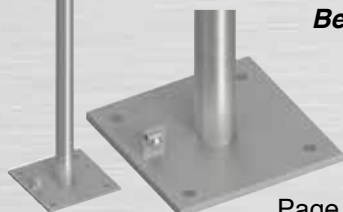

Page 61

- Benefits:**
- Air termination pole entirely in stainless steel.
  - Air termination pole max. 4m pole-part length.
  - Statically tested, taking into account
    - Ice accretion.
    - Gust reaction factor.
    - Static safety factor 1.5, required due to building authorities
  - Everything from one source.



2021

## HVC-protected

### Insulation test for HVC-50 and HVC-85

**J.P. Innovation:**



The HCV-50 and HVC-85 conductors are the first insulated conductors used in lightning protection that can be tested for function. Here, for the first time, it is possible to determine by a simple and practical measurement that no lightning-induced insulation breakdown of the insulated cables has occurred and that they are therefore still safe and fully functional. A real innovation from the house of J. Pröpster.

- Benefits:**
- Regular insulation testing of the HVC lines
  - Simple and practical implementation of the insulation test
  - Permanent protection can be guaranteed



Page 168



## HVC-protected - Air termination pole system for HVC-50 and HVC-85

free-standing resp. unsupported air termination pole system for HVC-50 and HVC-85 for HVC-exterior pole installation resp. meshed systems

- Benefits:**
- Transport length of the pole parts max. 2.8 m.
  - Telescopic air termination rod in aluminium.
  - Enormous saving of HVC conductor lengths for meshed systems.
  - Significantly less time required for the installation.
  - Separation distances better manageable due to shorter HVC-conductor lengths.



Pole height at delivery



Page 159

**J.P. -developments and innovations are becoming standards in lightning protection**

Stand: 07/2021



## "Germany's innovation leader" 2021

The F.A.Z. Institute - a subsidiary of the renowned "Frankfurter Allgemeine Zeitung" - has been honoured the company J. Pröpster GmbH with the certificate "Germany Innovation leader".

Therefore F.A.Z. Institute analyzed the patent applications of 170,000 German companies. Therefore the number of patents and their relevance was evaluated. J. Pröpster GmbH belongs to the top group of innovative German companies.



## Table of contents - Main catalogue 2021

Round wires, strips, cables

Page 37-40



Wires, Strips, Cables

Air termination systems

Page 41-62

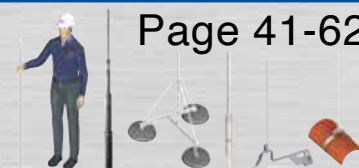

Air termination systems

Wall and roof conductor holder

Niro-Clip · Conductor fastener · Pipe clamps · Roof conductor holder

Page 63-82



Wall and roof conductor holders

PRÖCOLOR & colour design in lightning protection

Roof conductor holder in PRÖCOLOR · powder-coated components

Page 83-86



Colour design in lightning protection

Connection clamps, terminal clamps

Gutter clamps · System Multi-clamp · Disconnecting clamps · Connectors · System Vario-clamp · Saddle clamps · System bimetal · bridging components · Pipe clamps

Page 87-108



Connection and terminal clamps

Earthing material

Earth lead-in rods · Connection clamps · Earth rods · Tubular earth rods · Fixed earthing terminals

Page 109-130



Earthing material

Equipotential bonding systems

Bonding bars · Earthing busbars

Page 131-134



Equipotential bonding

Insulated lightning protection,

Insulated lightning protection air termination poles · Insulated stand-offs · Lightning protection for radio and mobile phone antennas

Page 135-146



Insulated lightning protection

HVC - high voltage conductor

HVC-50 conductor · HVC-85 conductor ·

Air termination poles for HVC · Conductor fastener for HVC · Equipotential bonding · Accessories

Page 147-170



HVC-Conductor

Accessories

Straightening device for wires and strips · Bolts and nuts · Earth tester

Page 171-176



Accessories

Surge protection

Power supply · photovoltaic systems · measurement and control technology · information technology · accessories

Page 177-197



Surge protection

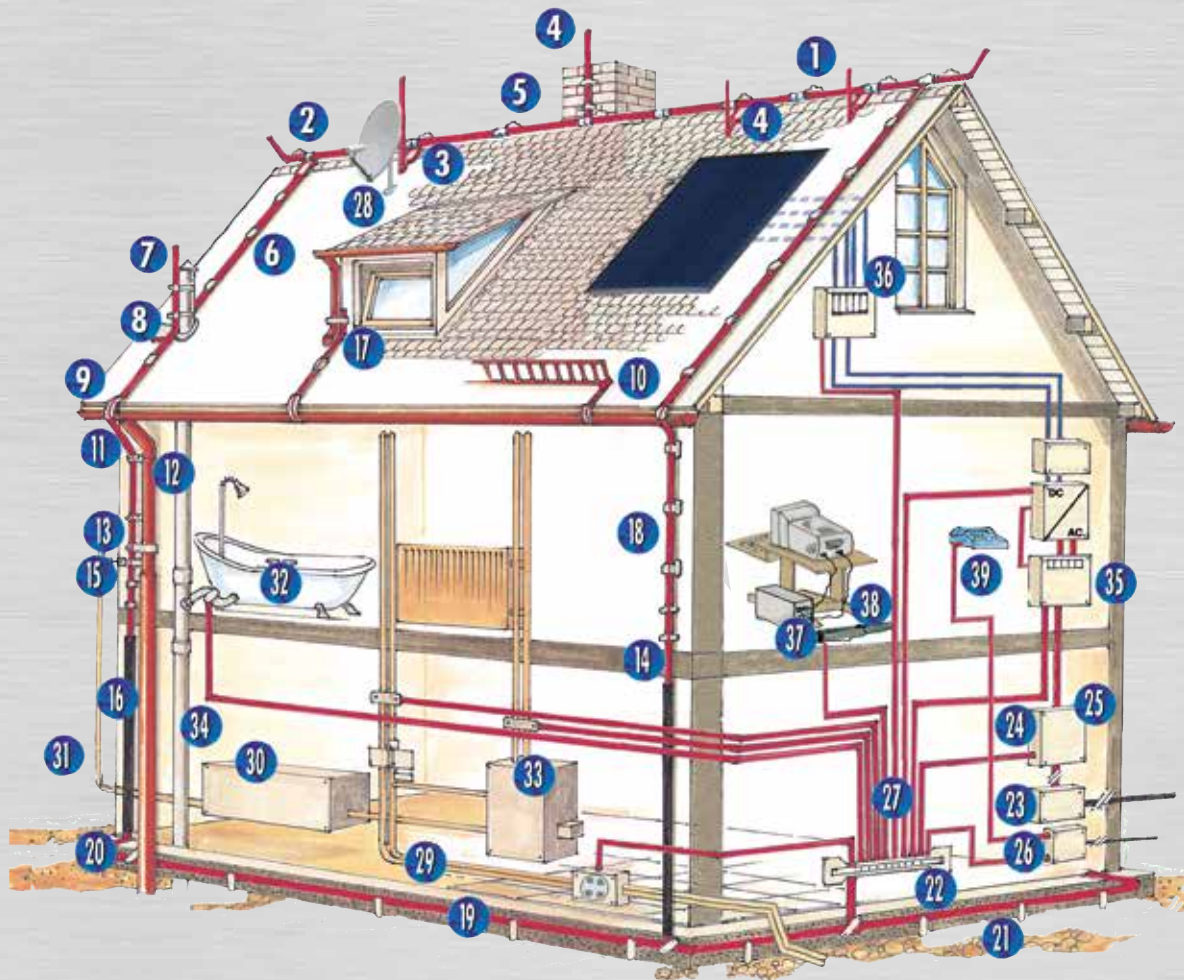

## External lightning protection system

- 1 Roof conductor holder for ridge tiles
- 2 Multi-clamp
- 3 Air termination rod with insulated stand-off
- 4 Air termination rod
- 5 Rod holder
- 6 Roof conductor holder
- 7 Pipe clamp
- 8 KS clamp
- 9 Gutter clamp
- 10 Snow guard clamp
- 11 Wall conductor holder
- 12 Downpipe conductor fastener
- 13 Isolating spark gap
- 14 Disconnecting clamp flat/round
- 15 Tape conductor holder
- 16 Insulation
- 17 Saddle clamp
- 18 Down conductor
- 19 Earth electrode
- 20 Diagonal-cross clamp
- 21 Spacer for conductor

## Internal lightning protection system

- 22 Main earthing terminal
- 23 House connection box
- 24 Main distribution board
- 25 Combined lightning current and surge arrester
- 26 Surge arrester for telecommunication
- 27 Equipotential bonding conductor
- 28 Antenna grounding / coax protection
- 29 Water supply
- 30 Oil tank
- 31 Oil tank ventilation
- 32 Bathtub
- 33 Heating system
- 34 Wastewater pipe
- 35 Surge arrester
- 36 Surge arrester for photovoltaic systems
- 37 Surge arrester for data networks
- 38 Surge arrester type 3
- 39 Telephone system

### Important Note:

The information about possible application areas for our products is intended as productspecific information only. Our technical application notes are the result of many years of experience and are made to the best of our knowledge. This information is, however, nonbinding, since the different possibilities of application and individual installation conditions that our products may be subjected to, lie outside our sphere of influence. We therefore recommend that you observe the current country-specific standards and check that the products in question are suitable for the intended application.

Use and installation of the products are outside of our control and are therefore the sole responsibility of the user.



# Round wires, strips, cables

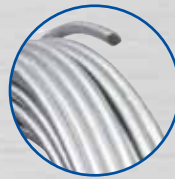
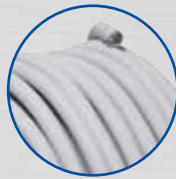
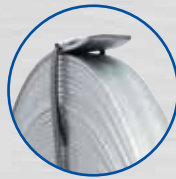



## Strips



Ord. no. 100 336



## Straightening tool for strips



Ord. no. 111 083

## Cables



Ord. no. 100 038



## Sign and protective cap



Ord. no. 102 220



Ord. no. 102 219

## Conductors for lightning protection and earthing systems

- Different materials.
- Available in various dimensions.

### Strips according to EN 62561-2.

Specification		Size	Weight/m	PU	Ord. no.
Steel, hot galvanized	Z 500	30 x 3.5 mm	0.84 kg	50 kg	100 336
Steel, hot galvanized	Z 500	30 x 3.5 mm	0.84 kg	25 kg	100 336 k
Steel, hot galvanized	Z 500	30 x 4.0 mm	0.96 kg	50 kg	113 231
Steel, hot galvanized	Z 500	40 x 4.0 mm	1.28 kg	50 kg	100 440
Steel, hot galvanized	Z 500	40 x 5.0 mm	1.60 kg	50 kg	100 540
Steel, hot galvanized	Z 500	20 x 2.5 mm	0.40 kg	50 kg	100 225
Stainless steel V2A 1.4301		30 x 3.5 mm	0.83 kg	50 kg	100 114
Stainless steel V2A 1.4301		30 x 3.5 mm	0.83 kg	25 kg	100 114 k
Stainless steel V4A (e.g. 1.4571)		30 x 3.5 mm	0.83 kg	50 kg	100 112
Stainless steel V4A (e.g. 1.4571)		30 x 3.5 mm	0.83 kg	25 kg	100 112 k
Stainless steel V4A (e.g. 1.4571)		40 x 4.0 mm	1.26 kg	50 kg	100 115
Stainless steel V4A (e.g. 1.4571)		40 x 5.0 mm	1.60 kg	50 kg	100 116
E-copper	medium	20 x 2.5 mm	0.45 kg	run.m.	100 118

**Straightened** and/or **perforated** strips on request (customized performance pattern).

Earthing components, like connection clamps, fixed earthing terminals, etc. on page 109.

Example for the on end installation of flat strips in the foundation area

Ord. no. 1321, 1319 or 1321 S on page 110:

### Straightening tool for strips with 5 levelling rolls, for strips 30 x 3.5 mm

Technical data	PU	Ord. no.
Weight: 23 kg, Length: 1390 mm, Width: 120* mm, Height: 670 mm (* base can be swivelled in) Uncoil, straighten and install in one step. Very easy handling, time saving due to clean, effortless and quick installation of earth strips.	1	111 083

### Cables according to EN 62561-2.

Specification according to EN 62561-2	Cross section	Weight/m	PU	Ord. no.
Aldrey cable	50 mm <sup>2</sup>	0.135 kg	run.m.	100 058
E-copper	bare 50 mm <sup>2</sup>	0.438 kg	run.m.	100 033
E-copper	bare 70 mm <sup>2</sup>	0.597 kg	run.m.	100 034
E-copper	bare 95 mm <sup>2</sup>	0.846 kg	run.m.	100 035
E-copper	bare 120 mm <sup>2</sup>	1.061 kg	run.m.	100 036
E-copper	tinned 50 mm <sup>2</sup>	0.438 kg	run.m.	100 037
E-copper	tinned 70 mm <sup>2</sup>	0.597 kg	run.m.	100 038
E-copper	tinned 95 mm <sup>2</sup>	0.846 kg	run.m.	100 039
E-copper	tinned 120 mm <sup>2</sup>	1.061 kg	run.m.	100 040
NY-Y-I underground cable E-copper 1 kV	50 mm <sup>2</sup>	0.615 kg	run.m.	100 043

### Cables for equipotential bonding.

Specification	Cross section	Outer diameter	Weight/m	PU	Ord. no.
Steel, hot galvanized	38 mm <sup>2</sup>	ø 10 mm	0.380 kg	run.m.	100 030
Stainless steel V4A 1.4401	27 mm <sup>2</sup>	ø 8 mm	0.250 kg	run.m.	100 041
Stainless steel V4A 1.4401	44 mm <sup>2</sup>	ø 10 mm	0.380 kg	run.m.	100 042

Conductor holder for cables on page 72

### Sign "ACHTUNG! Blitzschutz/Erdung" and Protective cap for earthing conductor





Specification	Length	Fit	PU	Ord. no.
Signpost PVC (printed on both sides)	200 x 50 mm	up to ø 10 mm or up to flat 40 x 4 mm	10	102 220

On request, also with your company logo and translated text. Price on request.

Protective cap plastic (HD-PE) yellow	ø 10 mm or flat 30 x 3.5 mm	50	102 219
---------------------------------------	-----------------------------	----	---------



## Round wires according to EN 62561-2.

Specification		Size	Weight/m	PU	Ord. no.
Steel, hot galvanized	Z 350	ø 8 mm	0.40 kg	40 kg	100 008
Steel, hot galvanized	Z 350	ø 10 mm	0.62 kg	50 kg	100 010
Aluminium AlMgSi 0.5	medium F 15	ø 8 mm	0.135 kg	20 kg	100 018
Aluminium AlMgSi 0.5	soft F 9	ø 8 mm	0.135 kg	20 kg	100 019
Aluminium	soft F 6	ø 10 mm	0.212 kg	20 kg	100 020
E-copper	medium F 25	ø 8 mm	0.45 kg	50 kg	100 028
E-copper	soft F 22	ø 8 mm	0.45 kg	50 kg	100 029
E-copper	soft F 22	ø 8 mm	0.45 kg	25 kg	100 029 k
Stainless steel V2A 1.4301		ø 8 mm	0.40 kg	~ 40 kg	100 011 
Stainless steel V2A 1.4301		ø 10 mm	0.62 kg	~ 50 kg	100 012 
Stainless steel V4A		ø 8 mm	0.40 kg	~ 40 kg	100 014 
Stainless steel V4A		ø 10 mm	0.62 kg	~ 50 kg	100 015 
Steel with PVC coating		ø 10/ø 13 mm	0.68 kg	50 kg	100 013
Steel with PVC coating		ø 8/ø 11 mm	0.44 kg	50 kg	100 121

**Aluminium wire, powder-coated, upon request.** For colour scale, see page 85, or according to your wishes

## ISO - Fugal down conductor wire according to EN 62561-2.

Specification	Size	Weight/m	PU	Ord. no.
Aluminum alloy AlMgSi 0.5 with halogen-free plastic coating	ø 8/ø 11 mm	0.20 kg	20 kg	100 123

## Round wire made of aluminium with copper coating

Specification		Size	Weight/m	PU	Ord. no.
Aluminium core with copper coating (Al/Cu)	soft	ø 8 mm	0.18 kg	20 kg	100 022

**Universal straightening tool**, with vertical reel-off unit, to be used for round wire ø 8 - 10 mm and for earth strips 30 x 3.5 mm.

Technical data	PU.	Ord. no.
Weight: 47 kg; Straightening device (as described on page 172) Vertical reel-off unit, adjustable to different ring diameters. Uncoiling of earth strips 30 x 3.5 also possible.	1	111 082

## Round wire



Ord. no. 100 010

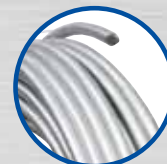

## ISO - Fugal down conductor wire



Ord. no. 100 123



## Round wire PräCu/Al



Ord. no. 100 022



## Universal straightening tool



Ord. no. 111 082



## Special components

Our long experience in the construction, development and manufacturing of lightning protection components, surge protection devices and earthing material has shown us that some lightning protection systems cannot be perfected using only the parts offered on the market.

For that reason, our company manufactures **special components according to your wishes and ideas** as

- punched parts
- turned parts
- cast parts
- welded constructions and
- special tools

according to drawings or samples out of

- stainless steel V2A and V4A
- copper
- steel or
- aluminium

in both small and large series.

## Special air termination rods & special holders in stainless steel and GRP



## Special mounting system in stainless steel for air termination rods



## Rope spans







# Air termination systems





## J.P. Selection guide for air-termination rods with a height of 1.5 - 3.5 m

Air termination systems

Height	Wind Zone	Concrete base Ord. no.	Support plate Ord. no.	Air termi- nation rod Ord. no.	Base frame Ord. no.	Max. wind speed		SET-No.
						Static safety factor 1.0	Static safety factor 1.5	
1.5m	Zone 1	103 103 1x 12 kg	103 102	103 111	-	177 km/h	145 km/h	912 075
	Zone 2	103 103 1x 12 kg (ø 380 mm)	103 102	103 111	-	177 km/h	145 km/h	
	Zone 2	103 191 1x 16 kg (Wedge connection 300x300 mm)	103 188	103 180	-	183 km/h	149 km/h	912 082
	Zone 3	103 101 1x 16 kg (ø 380 mm)	103 102	103 111	-	192 km/h	161 km/h	912 075 S
2.0m	Zone 1	103 101 1x 16 kg (ø 380 mm)	103 102	103 112	-	177 km/h	145 km/h	912 077
	Zone 2	103 101 1x 16 kg (ø 380 mm)	103 102	103 112	-	177 km/h	145 km/h	
	Zone 2	103 191 1x 16 kg (Wedge connection 300x300 mm)	103 188	103 181	-	168 km/h	137 km/h	912 083
	Zone 3	103 110 1x 20 kg (ø 380 mm)	103 102	103 112	-	189 km/h	160 km/h	912 077 S
2.5m	Zone 1	103 118 1x 25 kg (ø 420 mm)	103 102	103 113	-	158 km/h	132 km/h	912 078
	Zone 2	2x 103 101 2x 16 kg (930x380 mm)	2x 103 102	912 500		183 km/h	150 km/h	912 079 S
	Zone 3	2x 103 110 2x 20 kg (930x380 mm)	2x 103 102	912 500		198 km/h	167 km/h	912 079
3.0m	Zone 1	2x 103 101 2x 16 kg (930x380 mm)	2x 103 102	912 501		143 km/h	120 km/h	912 080
	Zone 2	2x 103 110 2x 20 kg (930x380 mm)	2x 103 102	912 501		165 km/h	135 km/h	912 081
	Zone 3	2x 103 118 2x 25 kg (970x420 mm)	2x 103 102	912 501		192 km/h	157 km/h	912 069
3.5m	Zone 1	3x 103 110 3x 20 kg (930x790 mm)	3x 103 102	912 502		145 km/h	120 km/h	912 068 S
	Zone 2	3x 103 118 3x 25 kg (970x830 mm)	3x 103 102	912 502		152 km/h	124 km/h	912 068
	Zone 3	(look at system: Air-termination pole set free-standing, Ord. no. 912 700)						

### Air termination rods for Zone 4 on request.

For the installation of air termination rods in Zone 4, further requirements regarding material (near to coast, material selection etc.) must be respected!

For an overview of the wind zone map, see page 52



## J.Pröpster optimal air termination rods with air termination tip

### Benefits:

- Visually attractive - optimal static designed.
- Ideal coordination of protective effects and material requirements.
- Minimum surface area exposed to the wind and maximum protection.
- Reduced load pressure on roof covering and insulation.

### J.Pröpster - Optimal air termination rods without thread

for concrete base 16 kg with J.Pröpster - wedge technology, according to EN 62561-2.

Specification	Length	PU	Ord. no.
<b>Tube air termination rod</b> , tube $\varnothing$ 16 x 3 mm with air termination tip $\varnothing$ 10 mm, 1 m long Material: <a href="#">Aluminium AlMgSi 0.5</a>	1500 mm	10	103 170
	2000 mm	10	103 171
	2500 mm*)	10	103 172
	3000 mm*)	10	103 173
	4000 mm*)	10	103 174
	5000 mm*)	10	103 174 S
	6000 mm*)	10	103 168

\*) only with additional, insulated stand-off (see page 140-144)

From 5 m also available in 2-parts (price on request)

### J.Pröpster - Optimal air termination rods without thread

for concrete base 16 kg with J.Pröpster - wedge technology, according to EN 62561-2.

Specification	Length	PU	Ord. no.
<b>Optimal air termination rod</b> $\varnothing$ 16 mm with air termination tip $\varnothing$ 10 mm, 1 m long Material: <a href="#">Aluminium AlMgSi 0.5</a>	1500 mm	10	103 180
	2000 mm	10	103 181
	2500 mm*)	10	103 182
	3000 mm*)	10	103 183

\*) only with additional, insulated stand-off (see page 140-144)

### Optimal air termination rods with M16 thread according to EN 62561-2

Specification	Length	PU	Ord. no.
<a href="#">Aluminium AlMgSi 0.5</a> $\varnothing$ 16 mm with M16 thread and air termination tip $\varnothing$ 10 mm, 1 m long longer than 2500 mm with lock nut	1500 mm	10	103 111
	2000 mm	10	103 112
	2500 mm*)	10	103 113
	3000 mm*)	10	103 114
	4000 mm*)	10	103 117
	5000 mm*)	10	103 128
	6000 mm*)	10	103 143

\*) only with additional, insulated stand-off (see page 140-144)

From 5 m also available in 2-parts (price on request)

### Air termination rods with M16 thread

for flat roofs and the protection of roof installations according to EN 62561-2

Specification	Length	PU	Ord. no.
Air termination rods $\varnothing$ 16 mm made of <a href="#">Aluminium AlMgSi 0.5</a> with M16 thread longer than 2500 mm with lock nut	1000 mm	10	103 100
	1500 mm	10	103 150
	2000 mm	10	103 200
	2500 mm*)	10	103 250

Additional lengths on request!

\*) only with additional, insulated stand-off (see page 140-144)

### Optimal air termination rod without thread



Ord. no. 103 170



Ord. no. 103 180

### Optimal air termination rod with M16 thread



Ord. no. 103 111

### Air termination rod with M16 thread



Ord. no. 103 100



## Air termination rods, $\varnothing 16$ mm



Ord. no. 100 750

## Air termination rod with M10 thread



Ord. no. 103 147

## Concrete base with M16 female thread



Ord. no. 103 103

## Support plate



Ord. no. 103 102

## Support tool



Ord. no. 103 189

Ord. no. 110 240

## Air termination rods, $\varnothing 16$ mm, chamfered on both sides, according to EN 62561-2.

Specification	Fit	Length	PU	Ord. no.
Steel, hot galvanized	$\varnothing 16$ mm	750 mm	10	100 750
Steel, hot galvanized	$\varnothing 16$ mm	1000 mm	10	101 000
Steel, hot galvanized	$\varnothing 16$ mm	1200 mm	10	101 200
Steel, hot galvanized	$\varnothing 16$ mm	1500 mm	10	101 500
Steel, hot galvanized	$\varnothing 16$ mm	2000 mm	10	101 002
E-Copper	$\varnothing 16$ mm	1000 mm	10	101 005
E-Copper	$\varnothing 16$ mm	1200 mm	10	101 205
E-Copper	$\varnothing 16$ mm	1500 mm	10	101 505
Stainless steel V2A	$\varnothing 16$ mm	1000 mm	10	102 005
Stainless steel V2A	$\varnothing 16$ mm	1200 mm	10	102 205
Stainless steel V2A	$\varnothing 16$ mm	1500 mm	10	102 505
Stainless steel V4A	$\varnothing 16$ mm	1000 mm	10	103 137
Stainless steel V4A	$\varnothing 16$ mm	1200 mm	10	102 207
Stainless steel V4A	$\varnothing 16$ mm	1500 mm	10	910 347
Aluminium AlMgSi 0.5	$\varnothing 16$ mm	1000 mm	10	102 000
Aluminium AlMgSi 0.5	$\varnothing 16$ mm	1200 mm	10	102 200
Aluminium AlMgSi 0.5	$\varnothing 16$ mm	1500 mm	10	102 550

Additional lengths on request!

Connection clamps  $\varnothing 8-10$  mm /  $\varnothing 16$  mm see page 50.

## Air termination rods with M10 thread

for flat roofs to protect roof installations, according to EN 62561-2.

Specification	Length	PU	Ord. no.
Air termination rods $\varnothing 10$ mm made of Aluminium AlMgSi 0.5 with M10 thread	500 mm	10	103 147
	750 mm	10	103 148
	1000 mm	10	103 124
Air termination rods $\varnothing 10$ mm made of Stainless steel V2A with M10 thread	1000 mm	10	103 106
	1200 mm	10	103 107

Additional lengths on request.

## Concrete base with stainless steel threaded sleeve for air termination rods with M16 thread for flat roofs to protect roof installations.

Specification	Weight	Diameter	PU	Ord. no.
Concrete base with female thread M16 as socket for air termination rods	12 kg	$\varnothing 380$ mm	1	103 103
	16 kg	$\varnothing 380$ mm	1	103 101
	20 kg	$\varnothing 380$ mm	1	103 110
	25 kg	$\varnothing 420$ mm	1	103 118

## Support plate for concrete base round (up to $\varnothing 445$ ) and concrete base (300 x 300 mm) to protect roofing material. Neutral to all conventional roof foils.

Specification	Diameter	PU	Ord. no.
Plastic, black - without plasticizer	$\varnothing 445$ mm 300 x 300 mm	1	103 102

The support plate for concrete base is necessary on synthetic roofing membranes.

## Support tool for concrete base

Specification	Size	PU	Ord. no.
Nylon tissue white	440 x 430 x 100 mm	1	103 189
Reinforced steel $\varnothing 12$ mm (coated) with soft PVC handle $\varnothing 14$ mm	for concrete base with wedge technology	1	110 240



## Concrete base with wedge technology

- Benefits:**
- Tilting of the air termination rod adjustable to the roof.
  - Curving the air termination is not necessary.
  - High quality: Wedge + clamp completely made of stainless steel V2A. 
  - Safety - "100 kA tested".
  - Specification: Compressed frost-proof concrete base 16 kg - with recessed grip.
  - Installation and price benefits: J.Pröpster wedge technology including connection clamp for the roof conductor -all in one.

### Concrete base with J.Pröpster - wedge technology, for air termination rods for flat roofs to protect roof installations.

Specification	Fit wege	PU	Ord. no.
Concrete base 16 kg; 300 x 300 x 80 mm with wedge connection clamp stainless steel V2A  for air termination rod ø 16 mm	ø 8 mm	1	103 191
<b>Support plate;</b> Neutral to all synthetic roofing membranes Plastic, black - without plasticizer		1	103 188

The support plate for concrete base is necessary on synthetic roofing membranes.

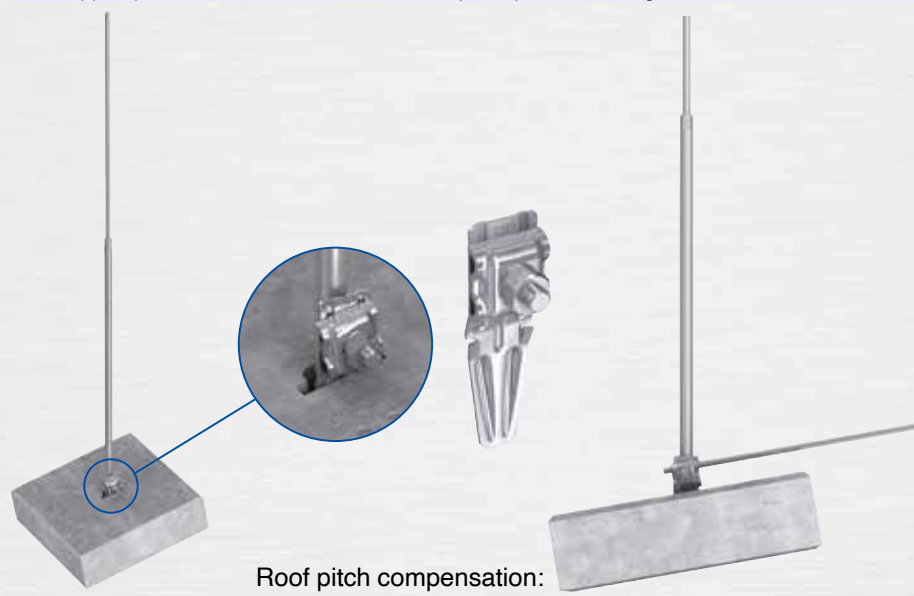

## Concrete base with wedge technology

(J&P patent)

Ord. no. 103 191

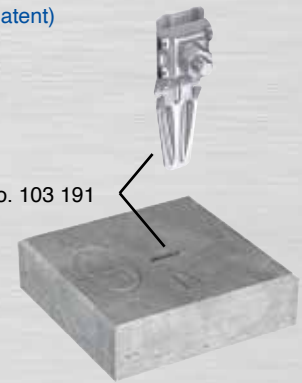

## Support plate

Ord. no. 103 188



### Concrete base for air termination rods for flat roofs to protect roof installations.

Specification	Weight	PU	Ord. no.
Concrete base 300 x 300 x 60 mm with female thread M10	12 kg	1	103 104
Concrete base 300 x 300 x 80 mm with female thread M10	16 kg	1	103 146

### Support plate for concrete base to protect roofing material. Neutral with all roofing materials.

Specification	Size	PU	Ord. no.
Plastic, black - without plasticizer	300 x 300 mm	1	103 188

The support plate for concrete base is necessary on synthetic roofing membranes.

## Concrete base with M10 female thread

Ord. no. 103 104



## Support plate

Ord. no. 103 188

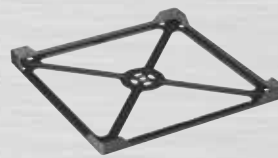



## k<sub>C</sub>-clamp

special clamp for cross connection of conductors  
incl. an additional air termination rod

### Benefits:

- All connection types (cross, T-, corner, parallel, end-to-end connection) and additional connection of one air termination rod or tip with solely one clamp.
- Connection of crossing points of conductor leading and one air termination rod also without concrete base.
- Easy k<sub>C</sub> value reduction by the factor 0.25 by splitting up the current path.
- Also to be used in existing systems.

### k<sub>C</sub>-clamp (J.P. patent)



Ord. no. 111 299

### k<sub>C</sub>-clamp with wedge technology (J.P. patent)



Ord. no. 111 296

### Concrete base for k<sub>C</sub>-clamp with wedge technology



Ord. no. 103 185

### k<sub>C</sub>-clamp according to EN 62561-1 class H (10/350μs)

Specification	Fit	Air termination rod	PU	Ord. no.
Aluminium - steel, hot galvanized	ø 8 mm / ø 8 mm	ø 16 mm	25	111 298
Aluminium - stainless steel V2A	ø 8 mm / ø 8 mm	ø 16 mm	25	111 299
Aluminium - stainless steel V2A	ø 8 mm / ø 8 mm	ø 10 mm	25	111 297

Examples of application:

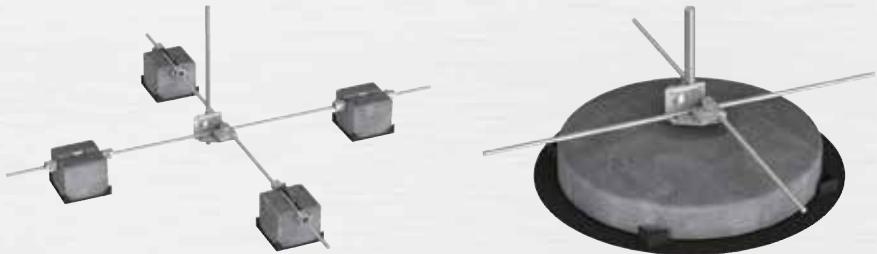

### Wedge technology incl. k<sub>C</sub>-clamp

according to EN 62561-1 class H (10/350μs)

Specification	Fit	Air termination rod	PU	Ord. no.
Aluminium - stainless steel V2A	ø 8 mm / ø 8 mm	ø 16 mm	25	111 296

Detail drawing of wedge fixture:

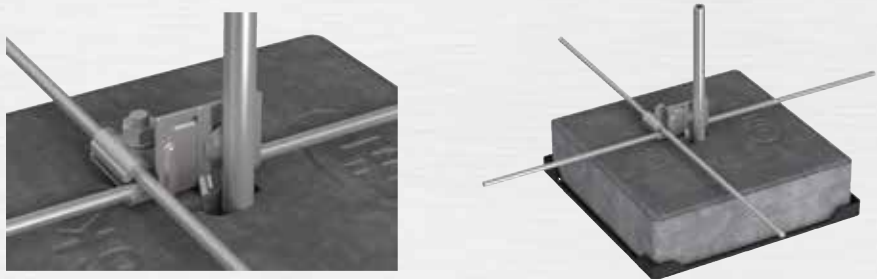

### Concrete base for k<sub>C</sub>-clamp with J.Pröpster wedge technology

Specification	PU	Ord. no.
Concrete base 16 kg; 300 x 300 x 80 mm for k <sub>C</sub> -clamp with wedge fixture	1	103 185
Support plate; neutral to all roof foils plastic (black) – without plasticizers	1	103 188

Foil roofs must have a support plate for the concrete base.



## Air termination rod holder for ridge tiles

### Benefits:

- Large range for ridge tiles with a width of 150 - 300 mm
- Fast and simple tool-free rough adjustment of the required clamping area by means of two symmetric clamping bracket with self-retaining locking catches
- Direct lightning-current capable connection of the ridge/down-conductor on the air termination rod holder.

**Air termination rod system** with a width of 150 - 300 mm, according to EN 62561-2.

Specification	Length	PU	Ord. no.
1 holder, <b>stainless steel V2A</b> and air termination rod, <b>aluminium</b> ø 10 mm	1050 mm	1	1250
2 holder with connection rail, <b>stainless steel V2A</b> and air termination rod, <b>aluminium</b> ø 16/10 mm	1500 mm	1	1251

Example of application:

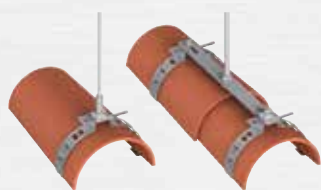

Note:  
Pay attention that each ridge tile is screw-fastened to the roof!

**Air termination rod system** for ridge tiles (size 200 - 220 mm) according to EN 62561-2.

Specification	Length	PU	Ord. no.
1 holder, <b>stainless steel V2A</b> and air termination rod, <b>aluminium</b> ø 10 mm	1050 mm	1	1255
2 holder, <b>stainless steel V2A</b> and air termination rod, <b>aluminium</b> ø 16/10 mm	1350 mm	1	1255 S2

Additional lengths on request!

Example of application:

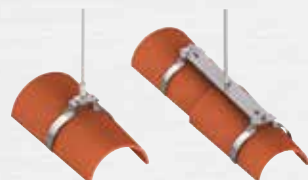

Note:  
Pay attention that each ridge tile is screw-fastened to the roof!

## Air termination rods for all common types of roof tiles

Infinitely adjustable to fit the tile, according to EN 62561-2.

Specification	Length	PU	Ord. no.
1 holder, <b>stainless steel V2A</b> - with air termination rod <b>aluminium</b> ø 10 mm	1000 mm	1	1254
2 holder with connection bar, <b>stainless steel V2A</b> - with air termination rod <b>aluminium</b> ø 16/10 mm	1500 mm	1	1254 S2
1 holder, <b>stainless steel V2A</b> - without air termination rod	-	1	1254 S1
2 holder with connection bar, <b>stainless steel V2A</b> - without air termination rod	-	1	1254 S3

**On request also available in desired RAL-colour.**

Example of application:

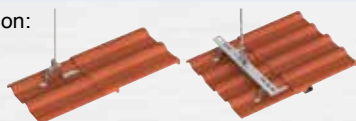

## Air termination rod

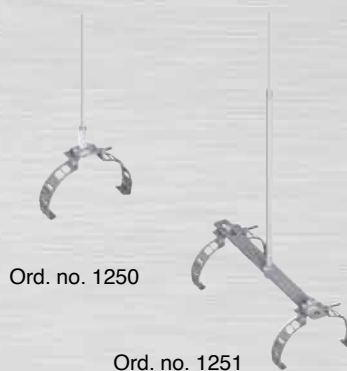

Ord. no. 1250

Ord. no. 1251

## Air termination rod



Ord. no. 1255

Ord. no. 1255 S2

## Air termination rod

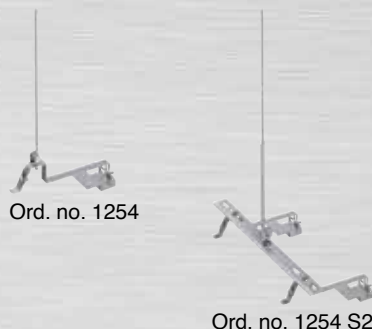

Ord. no. 1254

Ord. no. 1254 S2



## Air termination rod system

(J&P utility patent)

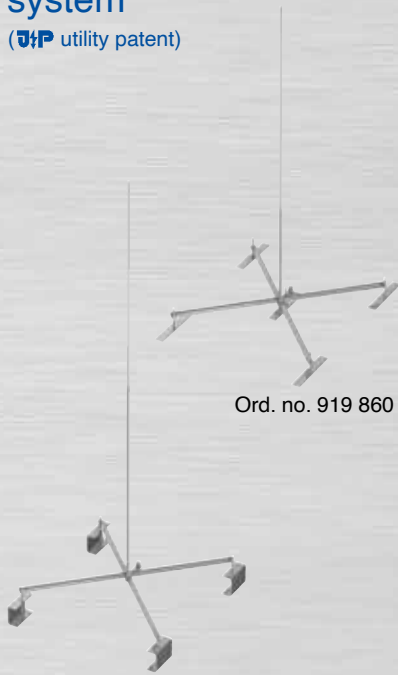

Ord. no. 919 860

Ord. no. 919 860 S

## Conductor fastener



Ord. no. 920 860

Ord. no. 920 860 B

## Roof pitch compensation



Ord. no. 920 181 S

Ord. no. 920 181

## Air termination rod system for metal / tin roofs (also for roof inclinations up to 10°)

**Air termination rod system** with mounting cross, bases incl. **magnetic plates** and KS-Connector, according to EN 62561-2.

Specification	Length	PU	Ord. no.
Mounting cross <b>stainless steel V2A</b> with 5 bases <b>stainless steel</b> incl. magnetic plate, Air termination rod <b>Aluminium</b> ø 16/10 mm, 1.5 m length and connection with KS-connector	1500 mm	1	919 860
Mounting cross <b>stainless steel V2A</b> with 4x St-profile each ~ 1.5 kg, magnetic plate, Air termination rod <b>aluminium</b> ø 16/10 mm 2.0 m length and connection with KS-connector	2000 mm	1	919 860 S
Mounting cross <b>stainless steel V2A</b> with 4x St-profile each ~ 2.0 kg, magnetic plate, Air termination rod <b>aluminium</b> ø 16/10 mm, 2.5 m length and connection with KS-connector	2500 mm	1	919 860 S1

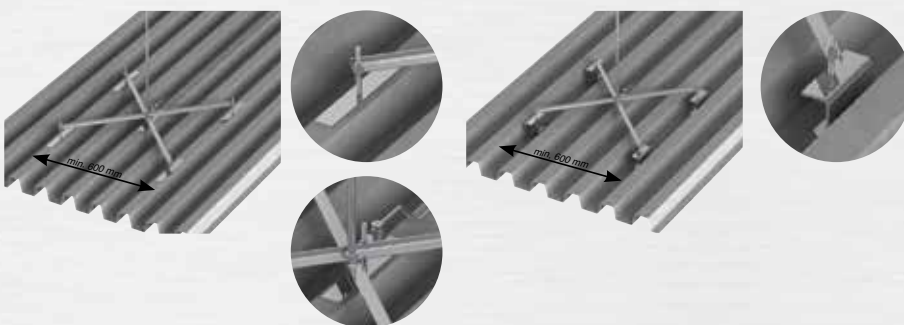

## Conductor fastener for metal / tin roofs

**Conductor fastener**, **stainless steel V2A** with magnetic plate and Niro-Clip **V2A**; for ø 8 mm loose conductor leading incl. plate **V2A** 180x40x3mm.

Specification	Fit	PU	Ord. no.
<b>Stainless steel V2A</b> with Niro Clip	ø 8 mm / <i>type B</i>	1	920 860

**Conductor fastener**, **stainless st. V2A** with magnetic plate, Niro-Clip **V2A** and spacer to raise the conductor distance for ø 8 mm loose conductor leading incl. plate **V2A** 180x40x3 mm.

Specification	Height	Fit	PU	Ord. no.
<b>Stainless steel V2A</b> with Niro Clip	80 mm	ø 8 mm / <i>type B</i>	1	920 860 B

\*) **type A (fl)** = fixed conductor leading; **type B (ll)** = loose conductor leading

**Roof pitch compensation** infinitely adjustable!  
Also suitable for concrete base with thread M16

Specification	Fit	PU	Ord. no.
Roof pitch compensation <b>stainless steel V2A</b> for air termination rods ø 16/10 mm <b>max. 1.5m length</b> and fixing with CC-Clamp.	ø 16 mm	1	920 181
Roof pitch compensation <b>stainless steel V2A</b> for air termination rods ø 16/10 mm <b>over 1.5m length.</b> and fixing with Vario-clamp.	ø 16 mm	1	920 181 S

Application example

Ord. no. 920 181 S in conjunction with Air termination rod system Ord. no. 919 860:







## Air termination rod system light-weight type suitable for Kalzip 50

according to EN 62561-1 and EN 62561-2

Specification	Length	PU	Ord. no.
<b>NEW!</b> Aluminium/stainless steel V2A complete with air termination rod aluminium ø 10 mm	1000 mm	1	111 300
<b>NEW!</b> Aluminium/stainless steel V2A complete with Optimal air termination rod ø 16 / ø 10 mm	1500 mm	1	111 301



## Air termination rods with mounting cross for Kalzip

according to EN 62561-1 and EN 62561-2.

Specification	Length	PU	Ord. no.
Stainless steel V2A complete with Optimal air termination rod (aluminium) and 4 Kalzip-mounting clamps (stainless steel V2A)	2000 mm	1	910 247
Stainless steel V2A without Optimal air termination rod and 4 Kalzip-mounting clamps (stainless steel V2A)	---	1	910 248
SET 4x Kalzip mounting clamp (stainless steel V2A) for mounting cross		1	910 242

## Air termination rods with mounting cross for RIB-ROOF 500

according to EN 62561-2.

Specification	Length	PU	Ord. no.
Stainless steel V2A complete with Optimal air termination rod (aluminium) and 4 RIB-ROOF-mounting clamps (stainless steel V2A)	2000 mm	1	910 257
Stainless steel V2A without Optimal air termination rod and 4 RIB-ROOF-mounting clamps (stainless steel V2A)	---	1	910 258
SET 4x RIB-ROOF mounting clamp (stainless steel V2A) for mounting cross		1	910 243

**Note:** For other lengths of the Optimal air termination rods with thread M16, see page 43.

## Air termination rods with mounting cross for standing seam

Clamping range up to 19 mm according to EN 62561-1 and EN 62561-2.

Specification	Length	PU	Ord. no.
Stainless steel V2A complete with Optimal air termination rod (aluminium) and 4 standing seam mounting clamps (stainless steel V2A)	2000 mm	1	912 505
Stainless steel V2A without Optimal air termination rod with 4 standing seam mounting clamps (stainless steel V2A)	---	1	912 506
SET 4x standing seam mounting clamps (stainless steel V2A) Clamping range up to 19 mm for mounting cross		1	924 192

Additional clamping range on request.

## Fangstangensystem



Best.-Nr. 111 300

## Air termination rod system for metal roofs



Ord. no. 910 247

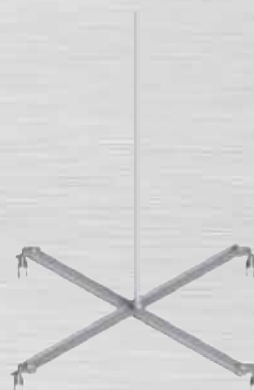

Ord. no. 910 257



Ord. no. 912 505



## Air termination tip



Ord. no. 103 158

## Air termination tip with base



Ord. no. 103 125

## Air termination stud



Ord. no. 2040

Ord. no. 2046

## Air termination tip



Ord. no. 1252

## U-Connector



Ord. no. 111 410

## Multi-Clamp ø 8-10 mm / ø 16 mm



Ord. no. 111 430

## Connection clamp for air termination rods ø 16 mm



Ord. no. 2108

50

**Aluminium-air termination tip** ø 10 mm with thread M10,  
for direct connection to Multi-clamps, for T- and cross connections, according to EN 62561-2.

Specification	Length	PU	Ord. no.
Aluminium AlMgSi 0.5 ø 10 mm with female thread M10	250 mm	10	103 158
	500 mm	10	103 121
	750 mm	10	103 122

Air termination tips in **stainless steel V2A** on request  
Example of application:



**Air termination tip with base** for flat roofs, to protect small roof installations.  
e.g. ventilation systems. For installation along the conductor routing, according to EN 62561-2.

Specification	PU	Ord. no.
Air termination tip with base consisting of: plastic cover (equal to PR-ÖKO 1; page 81), but with 2 kg frost proof concrete filling, contact clamp for conductors ø 8 mm and air termination tip ø 10 mm Aluminium, 1.0 m long	1	103 125

**Air termination stud** for walkable and passable flat roofs.

Specification	Installation depth	Fit	PU	Ord. no.
Aluminium/steel, hot galvanized	min 60 mm	ø 8-10 mm	10	2040
<b>NEW</b> Stainless steel V2A	min 80 mm	ø 8-10 mm	10	2046

**Air termination tip** for screwing on conductor ends

Specification	Fit	PU	Ord. no.
Aluminium with V2A-bolt M6 x 8 mm	ø 8 mm	100	1252
Copper-alloy with V2A-bolt copper plated M6 x 8 mm	ø 8 mm	100	1253

## Terminal and connection clamps for air termination rods

### U-Connector

with M10 hexagonal screw V2A for conductors ø 8-10 mm and air termination rods ø 16 mm.

Specification	Fit	PU	Ord. no.
Steel, hot galvanized	ø 8-10/ø 16 mm	100	111 410
Copper	ø 8-10/ø 16 mm	100	111 411
Stainless steel V2A	ø 8-10/ø 16 mm	100	111 412

### Multi-Clamp ø 8-10 mm / ø 16 mm

**Benefits:** The approved System Multi-Clamp for rod connections ø 16 mm.

Specification	Fit	PU	Ord. no.
Steel, hot galvanized	ø 8-10/ø 16 mm	50	111 430
Copper	ø 8/ø 16 mm	50	111 432
Stainless steel V2A	ø 8-10/ø 16 mm	50	111 433

### Connection clamp for air termination rods ø 16 mm

for the connection of 2 air termination rods ø 16 mm.

Specification	Fit	PU	Ord. no.
Aluminium, mounted with four M8 hexagonal screw stainless steel V2A	ø 16 mm	25	2108

**Air termination rods** for ridge area in **stainless steel V2A**; infinitely adjustable, according to EN 62561-2.

Specification	Length	PU	Ord. no.
<b>Holder stainless steel V2A type A:</b>			
with air termination tip <b>aluminium</b> ø 10 mm	1000 mm	1	1257
with air termination rod <b>aluminium</b> ø 16/10 mm	1500 mm	1	1257 S
<b>Holder stainless steel V2A type B</b> (adjustable to fit the roof inclination):			
with air termination rod <b>aluminium</b> ø 16/10 mm	2000 mm	1	1259
with air termination rod <b>aluminium</b> ø 16/10 mm	2500 mm	1	1259 S

## Air termination rod SET

**Air termination rod SET** - **stainless steel V2A** with air termination tip **aluminium**. with **stainless steel V2A** angular frame V2A 50x50x5mm for 2 or 3 concrete bases.

Specification	Footprint (mm)	Concrete base (optional)	Wind speed Static safety factor 1.5	Height	Ord. no.
<b>Stainless steel V2A / aluminium</b>	ca. 930 x 380	2x 16 kg (Ord. no. 103 101)	150 km/h	<b>2.5 m</b>	912 500
<b>Stainless steel V2A / aluminium</b>	ca. 970 x 420	2x 25 kg (Ord. no. 103 118)	157 km/h	<b>3.0 m</b>	912 501
<b>Stainless steel V2A / aluminium</b>	ca. 970 x 830	3x 25 kg (Ord. no. 103 118)	124 km/h	<b>3.5 m</b>	912 502

**Note:**

**Concrete bases (round) and support plates (ord. no. 103 102) must be ordered separately.**

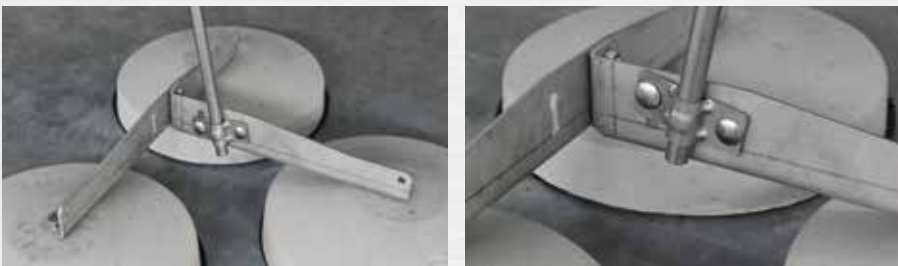

**NEW!** With integrated roof inclination adjustment up to 10° roof pitch and connection option (square 11 mm) at all corners.

## Concrete base

Specification	Weight	PU	Ord. no.
<b>Concrete base round</b> with female thread M16 for the base frame	12 kg	1	103 103
	16 kg	1	103 101
	20 kg	1	103 110
	25 kg	1	103 118
<b>Concrete base, 300 x 300 x 60 mm</b>	12 kg	1	499 100
<b>Concrete base, 300 x 300 x 80 mm</b>	16 kg	1	499 101
<b>Support plate, plastic black - without plasticizer</b>		1	103 102

## Air termination rod

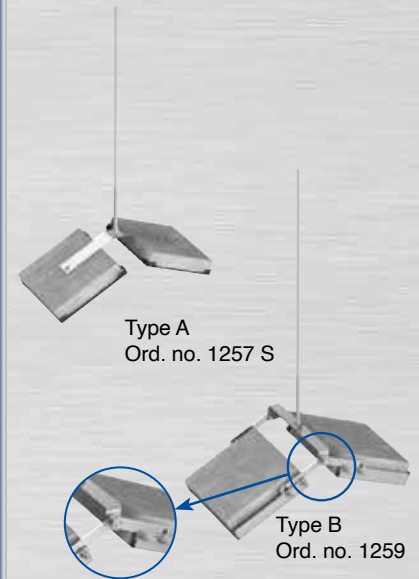

Air termination systems

## Air termination rod SET

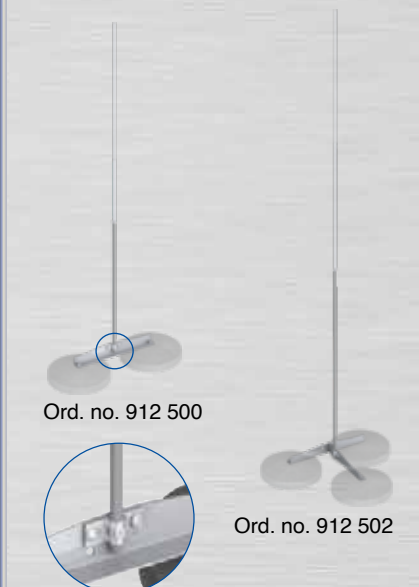

With integrated roof inclination adjustment up to 10° roof pitch

## Concrete base

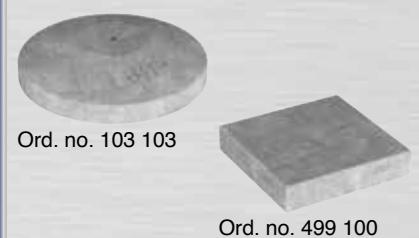



## Overview of gust wind speed according to (DIN) EN 1991-1-4 (part of Eurocode) Example: Map of Germany

Air termination systems

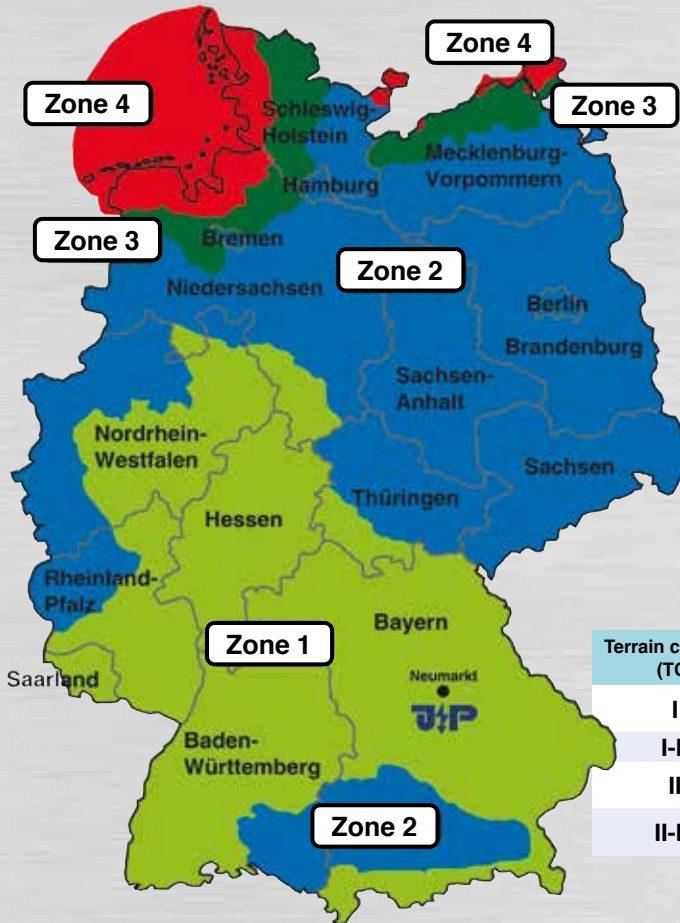

Terrain category (TC)	Description of terrain category (TC)
I	"Open sea; free lakes with at least 5 km surface wind direction; smooth, flat land without barriers."
I-II	Coastline territory, applicable in Zone 3 in most cases.
II	"Terrain with hedges, individual farmsteads, houses or tree, for example agricultural areas."
II-III	Inland, applicable in Zone 1 and Zone 2 in most cases (local land profile is often not clearly defined between TC II & III)

Height above ground in m	Zone 1 $v_{b,0}$ 22.5 m/s		Zone 2 $v_{b,0}$ 25.0 m/s		Zone 3 $v_{b,0}$ 27.5 m/s	Zone 4 $v_{b,0}$ 30.0 m/s
	TC II-III	TC II	TC II-III	TC II	TC I-II	TC I
0	100 km/h	106 km/h	111 km/h	118 km/h	133 km/h	151 km/h
5	100 km/h	109 km/h	111 km/h	120 km/h	137 km/h	160 km/h
10	106 km/h	118 km/h	118 km/h	131 km/h	150 km/h	171 km/h
15	115 km/h	124 km/h	127 km/h	137 km/h	158 km/h	178 km/h
20	121 km/h	129 km/h	134 km/h	142 km/h	165 km/h	182 km/h
25	126 km/h	132 km/h	139 km/h	146 km/h	170 km/h	186 km/h
30	130 km/h	135 km/h	144 km/h	149 km/h	174 km/h	190 km/h
40	138 km/h	140 km/h	152 km/h	154 km/h	181 km/h	195 km/h
50	143 km/h	143 km/h	158 km/h	158 km/h	186 km/h	199 km/h
60	147 km/h	147 km/h	162 km/h	162 km/h	189 km/h	202 km/h
70	150 km/h	150 km/h	165 km/h	165 km/h	192 km/h	205 km/h
100	156 km/h	156 km/h	172 km/h	172 km/h	198 km/h	212 km/h

**Notifications regarding static safety:**

A 1.5-fold stability safety applies to load-carrying constructions (houses, halls, bridges, radio towers) regarding the measured typical wind loads, i.e. load-carrying constructions must resist 1.5 times of the wind uplifting pressure.

This also applies to air termination poles, the failure or tilting of which can cause major economic damage, subsequent damage or personal damage on exposed positions (above a main building entrance, above a railway track etc.)

The builder or the owner must consider whether the a/m criteria apply to the planned site. If the a/m criteria do not apply, he must assume a 1.0-fold stability safety regarding the characteristic wind loads acc. to standard, i.e. the lightning termination rod can withstand only the maximum characteristic load (=1.5-fold) before it fails or collapses.

For example, a 4m air termination pole positioned at a distance of 10m from the edge of a flat roof with attic can protect an air conditioning against lightning strikes. In case of any doubt whether a 1.0-fold stability safety can be chosen, contact the insurance company. A 1.5-fold stability safety is always a safe approach.



## Selection guide for free standing air termination poles with a height of 3.0 - 12.0 m

Height of air termination pole	Wind Zone	Air termination pole base frame Ord. no.	Concrete base Ord. no.	Max. wind speed		SET-no.
				Static safety factor 1.0	Static safety factor 1.5	
<b>3.0m</b> (Ord. no. 912 000)	Zone 1	499 000	4x 499 100	211 km/h	172 km/h	912 089
	Zone 2	499 000	4x 499 100	211 km/h	172 km/h	
	Zone 3	499 000	4x 499 100	211 km/h	172 km/h	
<b>3.5m</b> (Ord. no. 912 001)	Zone 1	499 000	4x 499 100	177 km/h	145 km/h	912 090
	Zone 2	499 000	4x 499 100	177 km/h	145 km/h	
	Zone 3	499 000	4x 499 101	200 km/h	163 km/h	912 700
<b>4.0m</b> (Ord. no. 912 002)	Zone 1	499 000	4x 499 100	150 km/h	122 km/h	912 705
	Zone 2	499 000	4x 499 101	168 km/h	137 km/h	912 091
	Zone 3	499 000	8x 499 100	200 km/h	163 km/h	912 710
<b>4.5m</b> (Ord. no. 912 003)	Zone 1	499 005	3x 103 101	143 km/h	116 km/h	912 715
	Zone 2	499 005	3x 103 110	154 km/h	126 km/h	912 092
	Zone 3	499 005	3x 103 118	172 km/h	141 km/h	912 720
<b>5.0m</b> (Ord. no. 912 004)	Zone 1	499 005	3x 103 101	139 km/h	114 km/h	912 725
	Zone 2	499 005	3x 103 110	151 km/h	123 km/h	912 093
	Zone 3	499 005	3x 103 118	168 km/h	137 km/h	912 730
<b>5.5m</b> (Ord. no. 912 005) (Ord. no. 912 005 S)	Zone 1	499 005	3x 103 110	134 km/h	110 km/h	912 735
	Zone 2	499 005	3x 103 118	149 km/h	121 km/h	912 094
	Zone 3	499 006	6x 103 103	167 km/h	136 km/h	912 740
<b>6.0m</b> (Ord. no. 912 006)	Zone 1	499 006	6x 103 103	164 km/h	134 km/h	912 095
	Zone 2	499 006	6x 103 103	164 km/h	134 km/h	
	Zone 3	499 006	6x 103 103	164 km/h	134 km/h	
<b>6.5m</b> (Ord. no. 912 007)	Zone 1	499 006	6x 103 103	155 km/h	127 km/h	912 096
	Zone 2	499 006	6x 103 103	155 km/h	127 km/h	
	Zone 3	499 006	6x 103 101	170 km/h	139 km/h	912 745
<b>7.0m</b> (Ord. no. 912 008)	Zone 1	499 006	6x 103 103	136 km/h	111 km/h	912 750
	Zone 2	499 006	6x 103 101	148 km/h	121 km/h	912 097
	Zone 3	499 006	6x 103 110	160 km/h	131 km/h	912 755
<b>7.5m</b> (Ord. no. 912 009)	Zone 1	499 006	6x 103 101	141 km/h	116 km/h	912 760
	Zone 2	499 006	6x 103 110	153 km/h	125 km/h	912 098
	Zone 3	499 006	6x 103 118	168 km/h	137 km/h	912 765
<b>8.0m</b> (Ord. no. 912 010)	Zone 1	499 006	6x 103 118	147 km/h	120 km/h	912 099
	Zone 2	499 006	6x 103 118	147 km/h	120 km/h	
	Zone 3	499 007	10x 103 118	183 km/h	149 km/h	912 770
<b>9.0m</b> (Ord. no. 912 011)	Zone 1	499 007	10x 103 118	163 km/h	133 km/h	914 185
	Zone 2	499 007	10x 103 118	163 km/h	133 km/h	
	Zone 3	499 007	10x 103 118	163 km/h	133 km/h	
<b>10.0m</b> (Ord. no. 912 013)	Zone 1	499 007	10x 103 118	141 km/h	115 km/h	914 186
	Zone 2	499 007	10x 103 118	141 km/h	115 km/h	
	Zone 3	on request				on request
<b>11.0m</b> (Ord. no. 912 015)	Zone 1	499 009 / complete SET		181 km/h	148 km/h	912 061
	Zone 2	499 009 / complete SET		181 km/h	148 km/h	
	Zone 3	on request				on request
<b>12.0m</b> (Ord. no. 912 019)	Zone 1	499 009 / complete SET		177 km/h	145 km/h	912 070
	Zone 2	499 009 / complete SET		177 km/h	145 km/h	
	Zone 3	on request				on request

### Air termination poles for Zone 4 on request.

For the installation of air termination poles in Zone 4, further requirements regarding material (near to coast, material selection etc.) must be respected!



## Air termination pole

free-standing up to a max. height of 12.0 m

**Note: Air termination pole selection guide on page 55.**

**Air termination pole** - stainless steel V2A with aluminium air termination tip.  
Multi-component, on each other pluggable system with screw locking.

Type	Height of pole	Pole parts	PU	Ord. no.
JP-LPH 3.0 F	3.0 m	2-part, 1.5 m / 1.5 m	1	912 000
JP-LPH 3.5 F	3.5 m	2-part, 2.0 m / 1.5 m	1	912 001
JP-LPH 4.0 F	4.0 m	2-part, 2.5 m / 1.5 m	1	912 002
JP-LPH 4.5 F	4.5 m	2-part, 3.5 m / 1.0 m	1	912 003
JP-LPH 5.0 F	5.0 m	2-part, 3.5 m / 1.5 m	1	912 004
JP-LPH 5.5 F	5.5 m	2-part, 4.0 m / 1.5 m	1	912 005
JP-LPH 6.0 F	6.0 m	3-part, 2.0 m / 2.0 m / 2.0 m	1	912 006
JP-LPH 6.5 F	6.5 m	3-part, 2.5 m / 2.0 m / 2.0 m	1	912 007
JP-LPH 7.0 F	7.0 m	3-part, 3.0 m / 2.0 m / 2.0 m	1	912 008
JP-LPH 7.5 F	7.5 m	3-part, 3.5 m / 2.0 m / 2.0 m	1	912 009
JP-LPH 8.0 F	8.0 m	3-part, 4.0 m / 2.0 m / 2.0 m	1	912 010
JP-LPH 9.0 F	9.0 m	3-part, 4.0 m / 2.5 m / 2.5 m	1	912 011
JP-LPH 10.0 F	10.0 m	3-part, 5.0 m / 2.5 m / 2.5 m	1	912 013
JP-LPH 11.0 F	11.0 m	3-part, 5.0 m / 3.5 m / 2.5 m	1	912 015
JP-LPH 12.0 F	12.0 m	3-part, 6.0 m / 3.5 m / 2.5 m	1	912 019

Additional air termination pole heights on request!

## Air termination pole base frame

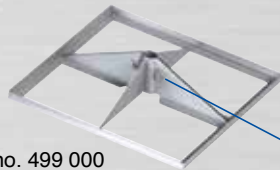

Ord. no. 499 000

## Support plate



Ord. no. 499 010

## Concrete base



Ord. no. 103 103

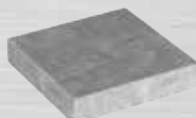

Ord. no. 499 100

## Air termination pole base frame with roof inclination adjustment up to 5°.

For concrete bases 300 x 300 mm to position air termination poles ø 42 mm (e.g. 111 496).

Specification	Footprint	PU	Ord. no.
Stainless steel V2A	ca. 650 x 650 mm	1	499 000
Support plate (one side aluminium-laminated)	ca. 650 x 650 mm	1	499 010
Roof inclination adjustment, inclination up to 10°		1	499 700



Roof inclination adjustment up to 5°

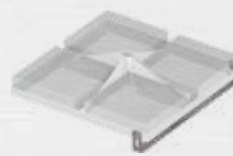

Roof inclination adjustment up to 10°  
Ord. no. 499 700.



Air termination pole base frame with **optional** concrete base  
Ord. no. 499 100.

## Concrete base

Specification	Weight	PU	Ord. no.
<b>Concrete base round</b> with female thread M16 for the base frame	12 kg	1	103 103
	16 kg	1	103 101
	20 kg	1	103 110
	25 kg	1	103 118
<b>Concrete base, 300 x 300 x 60 mm</b>	12 kg	1	499 100
<b>Concrete base, 300 x 300 x 80 mm</b>	16 kg	1	499 101
<b>Support plate, plastic black - without plasticizer</b>		1	103 102



## Air termination pole base frame

with a 2- or 3-part base frame for roof inclinations up to 3°

**Air termination pole base frame**, with **2-part base frame** and 3 safety braces for 3 round concrete bases for air termination poles  $\varnothing$  42 mm (max. 5.5 m pole height).

Specification	Pole base frame	Footprint	PU	Ord. no.
Stainless steel V2A	2-part	ca. 1350 x 1350 mm	1	499 005

**Air termination pole base frame**, with **2-part base frame** and 3 safety braces for 6 round concrete bases for air termination poles  $\varnothing$  60 mm (max. 8.0 m pole height).

Specification	Pole base frame	Footprint	PU	Ord. no.
Stainless steel V2A	2-part	ca. 1850 x 1850 mm	1	499 006

**Air termination pole base frame**, with **3-part base frame** and 3 safety braces for 6 round concrete bases for air termination poles  $\varnothing$  60 mm (max. 10.0 m pole height).

Specification	Pole base frame	Footprint	PU	Ord. no.
Stainless steel V2A	3-part	ca. 1850 x 1850 mm	1	499 007

**Note:**

Concrete bases (round) and support plates (ord. no. 103 102) must be ordered separately.

**Air termination pole base frame - SET incl. 36 concrete bases** with 4 safety braces and turnbuckle. For air termination poles  $\varnothing$  60 mm (max. 12.0 m pole height).

Specification	Footprint	PU	Ord. no.
Stainless steel V2A	ca. 3400 x 3400 mm	1	499 009

## Roof inclination adjustment for air termination poles

for roof inclinations up to 10°

### Roof inclination adjustment,

complete angle SET, stainless steel V2A with screw accessories.

Specification	for base frames with 3 round concrete bases	PU	Ord. no.
Stainless steel V2A	ord. no. 499 005	1	499 500

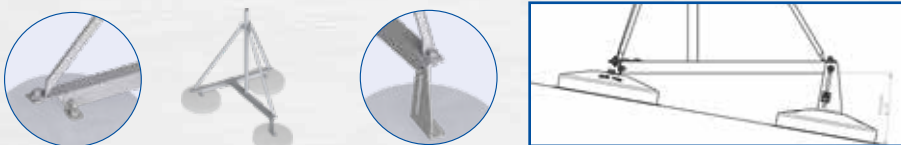

### Roof inclination adjustment,

complete angle SET, stainless steel V2A with screw accessories.

Specification	for base frames with 6 round concrete bases	PU	Ord. no.
Stainless steel V2A	ord. no. 499 006	1	499 600



## Base frame



Ord. no. 499 005



Ord. no. 499 006



Ord. no. 499 007

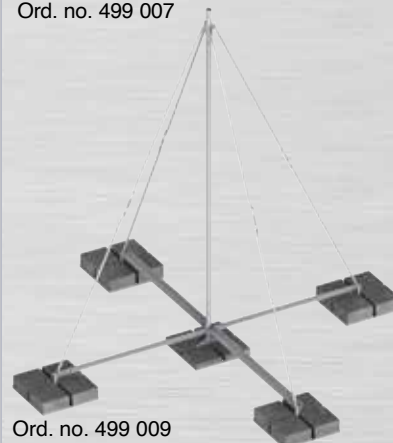

Ord. no. 499 009

## Roof inclination adjustment



Ord. no. 499 500



Ord. no. 499 600



## Telescopic-air termination pole

5°

Air termination systems

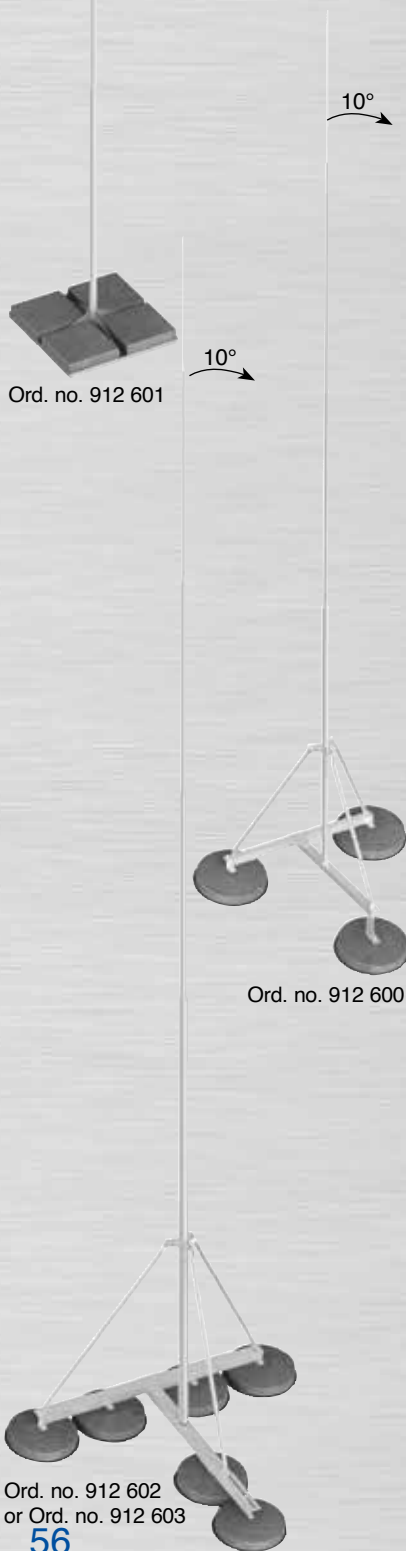

Ord. no. 912 601

Ord. no. 912 600

Ord. no. 912 602  
or Ord. no. 912 603

## Telescopic-air termination pole, free-standing aluminium with base frame for roof inclinations up to 10°

(J.P. utility patent)

### Benefits:

- Less space required for storage and in transport vehicle (**transport / delivery length ca. 2 m**).
- Adjustment of roof inclination up to max. 10°.
- Easy transport in lifts, staircases and through roof openings.
- Shorter and easier assembly of the air termination pole with self-locking set screws M8 or M10.
- Pole heights in the SET adjustable up to 4.35 m, 5.5 m, 6.5 m & 8.0 m.
- Statically calculated according to Eurocode (EC)

## Telescopic-air termination pole-SET in aluminium, freestanding incl. base frame with roof inclination adjustment, concrete bases and support plates.

Height of pole	Pole parts	Base frame	Concrete base	Ord. no.
up to 4.35 m	4-part	499 000 (5°)	4x 16 kg	912 601
up to 5.50 m	4-part	912 300 (10°)	3x 25 kg	912 600
up to 6.50 m	5-part	912 310 (10°)	6x 12 kg	912 602
up to 8.00 m	6-part	912 311 (10°)	6x 25 kg	912 603

Note: The air termination pole base frame must be secured against slipping from a roof inclination of 5°.

Roof inclination adjustment up to 10° (ord. no. 499 700) for the base frame (ord. no. 499 000) see on page 54.

### Wind speed according to Eurocode:

Height of pole	SET ord. no.	Wind speed	
		Static safety factor 1.0	Static safety factor 1.5
up to 4.35 m	912 601	146 km/h	119 km/h
up to 5.50 m	912 600	161 km/h	130 km/h
up to 6.50 m	912 602	142 km/h	116 km/h
up to 8.00 m	912 603	155 km/h	127 km/h

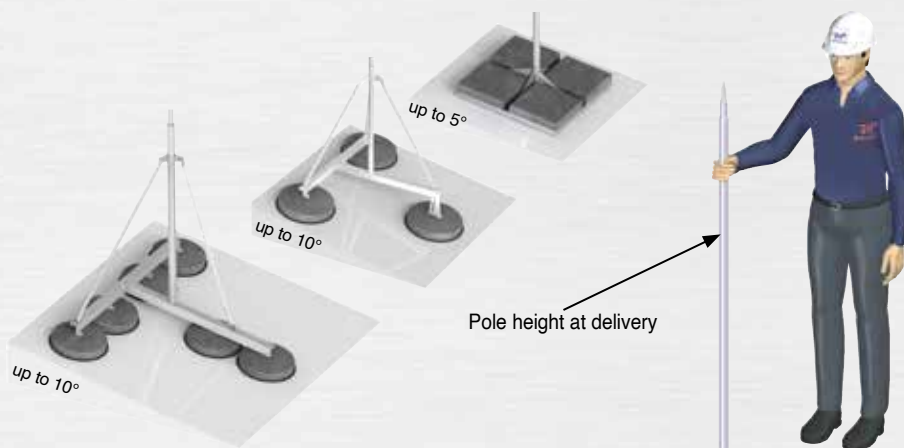





## Air termination pole for wall mounting - wind speed according to Eurocode

Height of air termination pole	Ord.-no.	Wall mounting	UL 1	CL 1	CL 2	Max. wind speed	
						Static safety factor 1.0	Static safety factor 1.5
Air termination pole for wall mounting in <b>stainless steel V2A</b>							
3.0 m	912 000 W	2x Type A	2.5 m	0.5 m	-	150 km/h	123 km/h
3.5 m	912 001 W	2x Type A	2.8 m	0.7 m	-	158 km/h	129 km/h
4.0 m	912 002 W	2x Type A	3.0 m	1.0 m	-	156 km/h	127 km/h
4.5 m	912 003 W	2x Type B	3.8 m	0.7 m	-	196 km/h	160 km/h
5.0 m	912 004 W	2x Type B	4.3 m	0.7 m	-	196 km/h	160 km/h
5.5 m	912 005 W	2x Type B	4.5 m	1.0 m	-	196 km/h	160 km/h
6.0 m	912 006 W	2x Type C	5.0 m	1.0 m	-	198 km/h	162 km/h
6.5 m	912 007 W	2x Type C	5.5 m	1.0 m	-	198 km/h	162 km/h
7.0 m	912 008 W	2x Type C	6.0 m	1.0 m	-	198 km/h	162 km/h
7.5 m	912 009 W	2x Type C	6.5 m	1.0 m	-	198 km/h	162 km/h
8.0 m	912 010 W	2x Type C	7.0 m	1.0 m	-	200 km/h	163 km/h
9.0 m	912 011 W	3x Type C	7.7 m	1.3 m	0.5 m	200 km/h	163 km/h
10.0 m	912 013 W	3x Type C	8.7 m	1.3 m	0.5 m	175 km/h	145 km/h
11.0 m	912 015 W	3x Type C	9.4 m	1.6 m	0.6 m	175 km/h	145 km/h
12.0 m	912 019 W	3x Type C	10.4 m	1.6 m	0.6 m	157 km/h	128 km/h
Telescopic air termination pole in <b>Aluminium</b> for wall mounting ↑							
up to 4.35 m	912 401	2x Type A	3.35 m	1.00 m	-	149 km/h	122 km/h
up to 5.35 m	912 400	2x Type B	4.65 m	0.70 m	-	196 km/h	160 km/h
up to 6.50 m	912 402	2x Type C	5.50 m	1.00 m	-	198 km/h	162 km/h
up to 8.00 m	912 403	2x Type C	7.00 m	1.00 m	-	200 km/h	163 km/h

Air termination poles with air termination tip aluminium are generally not designed for WZ4 (fatigue strength of the material, type of wind load).

The specified wind speeds regarding the 1.0-fold stability safety are not linear applicable for the use in WZ4 or for ground level > 1000m ASL.

Air termination pole with wall mounting for the installation in Zone on request.

### Explanation clamping lengths for the air termination poles with wall fastener

Example: 3.0 m air termination pole 912 000 W + 2x wall fastener type A

CL1 = 0.5 m  
UL1 = 2.5 m

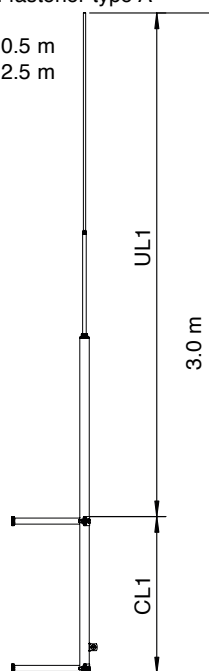

Beispiel: 10.0 m air termination pole 912 013 W + 3x wall fastener type Typ C

CL1 = 1.3 m  
CL2 = 0.5 m  
UL1 = 8.7 m

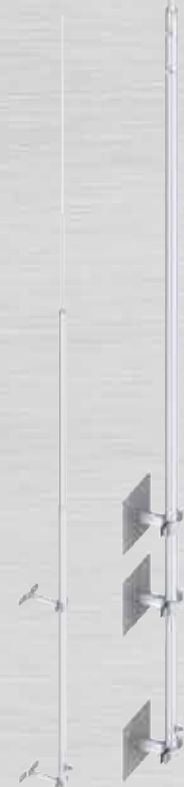
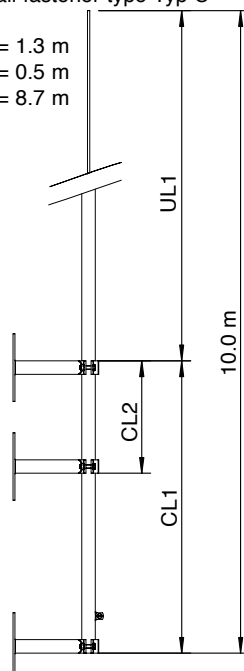



## Air termination pole for wall mounting unsupported for poles up to max. 12.0 m length

**Air termination pole** - stainless steel V2A with aluminium air termination tip.  
Multi-component, on each other pluggable system with screw locking.  
Incl. connection lug with clamping screw "KS" and slip-proofing.

Height of pole	Necessary wall fastener	Pole parts	PU	Ord. no.
3.0 m	2x Type A	2-part, 1.5 m / 1.5 m	1	912 000 W
3.5 m	2x Type A	2-part, 2.0 m / 1.5 m	1	912 001 W
4.0 m	2x Type A	2-part, 2.5 m / 1.5 m	1	912 002 W
4.5 m	2x Type B	2-part, 3.5 m / 1.0 m	1	912 003 W
5.0 m	2x Type B	2-part, 3.5 m / 1.5 m	1	912 004 W
5.5 m	2x Type B	2-part, 4.0 m / 1.5 m	1	912 005 W
6.0 m	2x Type C	3-part, 2.0 m / 2.0 m / 2.0 m	1	912 006 W
6.5 m	2x Type C	3-part, 2.5 m / 2.0 m / 2.0 m	1	912 007 W
7.0 m	2x Type C	3-part, 3.0 m / 2.0 m / 2.0 m	1	912 008 W
7.5 m	2x Type C	3-part, 3.5 m / 2.0 m / 2.0 m	1	912 009 W
8.0 m	2x Type C	3-part, 4.0 m / 2.0 m / 2.0 m	1	912 010 W
9.0 m	3x Type C	3-part, 4.0 m / 2.5 m / 2.5 m	1	912 011 W
10.0 m	3x Type C	3-part, 5.0 m / 2.5 m / 2.5 m	1	912 013 W
11.0 m	3x Type C	3-part, 5.0 m / 3.5 m / 2.5 m	1	912 015 W
12.0 m	3x Type C	3-part, 6.0 m / 3.5 m / 2.5 m	1	912 019 W



## Telescopic air-termination pole aluminium for wall mounting unsupported up to 6.5 m air termination pole height (mounting length 1.5m)

Height of pole	Necessary wall fastener	Pole parts	PU	Ord. no.
up to 4.35 m	2x Type A	4-part	1	912 401
up to 5.35 m	2x Type B	4-part	1	912 400
up to 6.50 m	2x Type C	5-part	1	912 402
up to 8.00 m	2x Type C	6 part	1	912 403





**Wall fastener** for poles with a max. height of 4.0 m and  $\varnothing$  42 mm.  
Hole pattern for rivet and screw mounting and 2 x  $\varnothing$  10.5 mm.

Specification	Wall distance	PU	Ord. no.
Completely in <b>stainless steel V2A for <math>\varnothing</math> 42 mm</b>	150 mm	1	490 550
pole clamp with 2 x screws M10	200 mm	1	490 551
spring lock washer and nut in <b>V2A</b>	250 mm	1	490 552
	300 mm	1	490 553

**Wall fastener** for poles with a max. height of 5.5 m and  $\varnothing$  42 mm.  
Hole pattern 4 x  $\varnothing$  10.5 mm.

Specification	Wall distance	PU	Ord. no.
Completely in <b>stainless steel V2A for <math>\varnothing</math> 42 mm</b>	150 mm	1	490 560
pole clamp with 2 x screws M10,	200 mm	1	490 561
spring lock washer and nut in <b>V2A</b>	250 mm	1	490 562
mounting plate <b>V2A</b> : 200 x 200 x 8 mm	300 mm	1	490 563
hole pattern mounting plate: $\square$ 170 x 170 mm			

**Wall fastener** for poles with a max. height of 12.0 m and  $\varnothing$  60 mm.  
Hole pattern 4 x  $\varnothing$  12.5 mm.

Specification	Wall distance	PU	Ord. no.
Completely in <b>stainless steel V2A for <math>\varnothing</math> 60 mm</b>	150 mm	1	490 570
pole clamp with 2 x screws M16,	200 mm	1	490 571
spring lock washer and nut in <b>V2A</b>	250 mm	1	490 572
mounting plate <b>V2A</b> : 300 x 300 x 8 mm	300 mm	1	490 573
hole pattern mounting plate: $\square$ 260 x 260 mm			

**Fixing anchors**, **stainless steel V4A** for wall fastener on concrete walls.

Specification	PU	Ord. no.
M10 for wall fastener Type A and Type B	1	490 548
M12 for wall fastener Type C	1	490 549

**Air termination pole fastener** for steel constructions (e.g. side rails)  
consisting of: Holder V2A on profile and pole holder V2A (cross clamp).

Specification	Profile	Fit in inch	Square profile	PU	Ord. no.
<b>Round profile</b>					
<b>Stainless steel V2A</b>	$\varnothing$ 26.9 mm	3/4"		1	490 490
<b>Stainless steel V2A</b>	$\varnothing$ 42.4 mm	1 1/4"		1	490 491
<b>Stainless steel V2A</b>	$\varnothing$ 48.5 mm	1 1/2"		1	490 492
<b>Square profile</b>					
<b>Stainless steel V2A</b>		suitable for	20 x 20 mm to 50 x 50 mm	1	490 495

Additional diameters and dimensions on request.

**Air termination pole fastener** for poles up to 5.5 m height and  $\varnothing$  42 mm.  
Tape pipe clamp **V2A** for clamping range up to 800 mm.

Specification	Wall distance	PU	Ord. no.
Completely in <b>stainless steel V2A for <math>\varnothing</math> 42 mm</b>	150 mm	1	490 540
pole clamp with 2 x screws M10,	200 mm	1	490 541
spring lock washer and nut in <b>V2A</b>	250 mm	1	490 542
Tape pipe clamp with 2 x screws M8 <b>V2A</b>	300 mm	1	490 543

## Wall fastener

### Type A:



Ord. no. 490 550

### Type B:

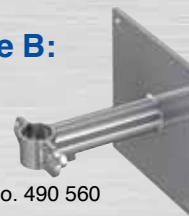

Ord. no. 490 560

### Type C:



Ord. no. 490 570

## Fixing anchors



Ord. no. 490 548

## Air termination pole fastener



Ord. no. 490 491



Ord. no. 490 495



Ord. no. 490 540



## Air termination pole - SET

Air termination systems

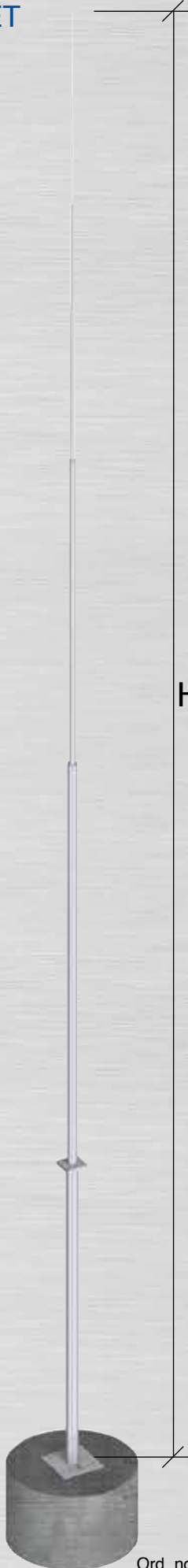

60

Ord. no. 912 205

## Lightning protection - air termination pole – SET with prefabricated concrete foundation

### Benefits:

- Air termination pole entirely in stainless steel. 
- Prefabricated foundation including transport aid.
- Air termination pole max. 4m pole-part length.
- No trench works.
- No excavation work from a static point of view.
- Statically tested, taking into account
  - Ice accretion.
  - Gust reaction factor.
  - Static safety factor 1.5, required due to building authorities
- Everything from one source.

**Air termination pole - SET with flange plate**, complete in stainless steel with aluminium tip and prefabricated foundation for max. Wind Zone 2.

Type	Height (H)	Foundation	Total weight	Ord. no.
JP-BFF 6.0	6.0 m	Ø 0.96 m / FH 0.5 m	ca. 924 kg	912 180
JP-BFF 7.0	7.0 m	Ø 0.96 m / FH 0.5 m	ca. 929 kg	912 182
JP-BFF 8.0	8.0 m	Ø 0.96 m / FH 0.5 m	ca. 932 kg	912 184
JP-BFF 9.0	9.0 m	Ø 0.96 m / FH 0.5 m	ca. 968 kg	912 186
JP-BFF 10.0	10.0 m	Ø 0.96 m / FH 0.5 m	ca. 976 kg	912 200
JP-BFF 11.0	11.0 m	Ø 0.96 m / FH 0.5 m	ca. 978 kg	912 201
JP-BFF 12.0	12.0 m	Ø 0.96 m / FH 0.5 m	ca. 986 kg	912 202
JP-BFF 13.0	13.0 m	Ø 1.16 m / FH 0.5 m	ca. 1,414 kg	912 203
JP-BFF 14.0	14.0 m	Ø 1.16 m / FH 0.5 m	ca. 1,423 kg	912 204
JP-BFF 15.0	15.0 m	Ø 1.16 m / FH 0.75 m	ca. 2,031 kg	912 205
JP-BFF 16.0	16.0 m	Ø 1.16 m / FH 0.75 m	ca. 2,083 kg	912 206
JP-BFF 17.0	17.0 m	Ø 1.16 m / FH 1.0 m	ca. 2,798 kg	912 207
JP-BFF 18.0	18.0 m	Ø 1.16 m / FH 1.0 m	ca. 2,806 kg	912 208

**Transport aid**, complete in stainless steel, for easy lifting the JP - prefabricated concrete foundation, e. g. with forklift truck

Specification	Hole pattern	PU	Ord. no.
Stainless steel V2A	for 4x M12, 4x M16 and 4x M20	1	912 180



Transport aid ord. no. 912 240

**JP prefabricated concrete foundation with 4 load anchors made of stainless steel (M12, M16 and M20) for easy installation of the air termination pole.**



Delivery condition with already set load anchors

### Note:

**All air termination poles are suitable for Wind Zone 2 up to 150 km/h. Wind Zone 3/4 and other dimensions on request.**



## Lightning protection - air termination pole with flange plate

### Benefits:

- Air termination pole entirely in stainless steel.
- Air termination pole max. 4m pole-part length.
- Statically tested, taking into account
  - Ice accretion.
  - Gust reaction factor.
  - Static safety factor 1.5, required due to building authorities
- Everything from one source.

**Air termination pole with flange plate**, complete in stainless steel with aluminium tip. For fastening to existing concrete surface on site; max. Wind Zone (WZ) 2.

Type	Height (H)	Hole pattern flange plate	Heavy-duty anchor	Ord. no.
JP-FP 6.0	6.0 m	□ 260 x 260 mm	4x M12	912 181
JP-FP 7.0	7.0 m	□ 260 x 260 mm	4x M12	912 183
JP-FP 8.0	8.0 m	□ 260 x 260 mm	4x M12	912 185
JP-FP 9.0	9.0 m	□ 300 x 300 mm	4x M16	912 187
JP-FP 10.0	10.0 m	□ 300 x 300 mm	4x M16	912 210
JP-FP 11.0	11.0 m	□ 300 x 300 mm	4x M16	912 211
JP-FP 12.0	12.0 m	□ 300 x 300 mm	4x M16	912 212
JP-FP 13.0	13.0 m	□ 300 x 300 mm	4x M16	912 213
JP-FP 14.0	14.0 m	□ 300 x 300 mm	4x M16	912 214
JP-FP 15.0	15.0 m	□ 300 x 300 mm	4x M16	912 215
JP-FP 16.0	16.0 m	□ 300 x 300 mm	4x M20	912 216
JP-FP 17.0	17.0 m	□ 300 x 300 mm	4x M20	912 217
JP-FP 18.0	18.0 m	□ 300 x 300 mm	4x M20	912 218

Foot flange plate made of stainless steel V2A including ground connection for  $\varnothing$  10 mm



## Air termination pole with flange plate

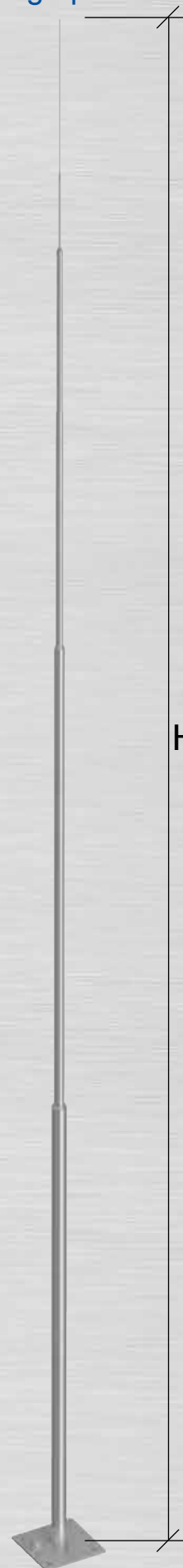

Air termination systems

### Note:

**All air termination poles are suitable for Wind Zone 2 up to 150 km/h.**  
Wind Zone 3/4 and other dimensions on request.



## Lightning protection - air termination pole for block foundations

This system was developed to protect objects and installations, such as areas with potentially explosive atmospheres, power distributors, transformer stations, biogas plants or other facilities with especially hazardous areas.

To ensure compliance with the valid standard EN 62305 1-4 we recommend the installation of an insulated lightning air termination system using air termination poles. With this method, it is also possible to completely encase larger objects within a protective zone and avoid bridging horizontally installed air termination conductors.

The air termination pole is embedded in a concrete block foundation that must be prefabricated on site according to our instructions. Please request our data sheet JP-LPH/BFM, with all the important information about the block foundation.

**Lightning protection pole** - Steel, hot galvanized (inside and outside). Multi-part, conic pluggable system with air termination rod (0.3 m - 1.5 m) and earthing connection.

Type	Height (H)	Pole diameter		Weight (entire pole)	Parts	Ord. no.
		top	bottom			
JP-LPH 9.5	9.5 m	58 mm	153 mm	ca. 100 kg	3 -part	920 700
JP-LPH 10.5	10.5 m	58 mm	153 mm	ca. 101 kg	3 -part	920 701
JP-LPH 11.5	11.5 m	89 mm	189 mm	ca. 158 kg	3 -part	920 702
JP-LPH 14.0	14.0 m	58 mm	189 mm	ca. 181 kg	4 -part	920 703
JP-LPH 15.0	15.0 m	89 mm	224 mm	ca. 256 kg	4 -part	920 704
JP-LPH 16.0	16.0 m	89 mm	224 mm	ca. 257 kg	4 -part	920 705
JP-LPH 17.5	17.5 m	108 mm	264 mm	ca. 361 kg	4 -part	920 706
JP-LPH 18.5	18.5 m	108 mm	264 mm	ca. 362 kg	4 -part	920 707
JP-LPH 20.5	20.5 m	89 mm	264 mm	ca. 385 kg	5 -part	920 708
JP-LPH 22.0	22.0 m	139 mm	344 mm	ca. 737 kg	3 -part	920 709
JP-LPH 25.0	25.0 m	108 mm	344 mm	ca. 790 kg	4 -part	920 710
JP-LPH 28.0	28.0 m	89 mm	344 mm	ca. 813 kg	5 -part	920 711

**Note:**

All air termination poles are suitable for Wind Zone 2 up to 150 km/h. Wind Zone 3/4 and other dimensions on request.





# Wall and roof conductor holders

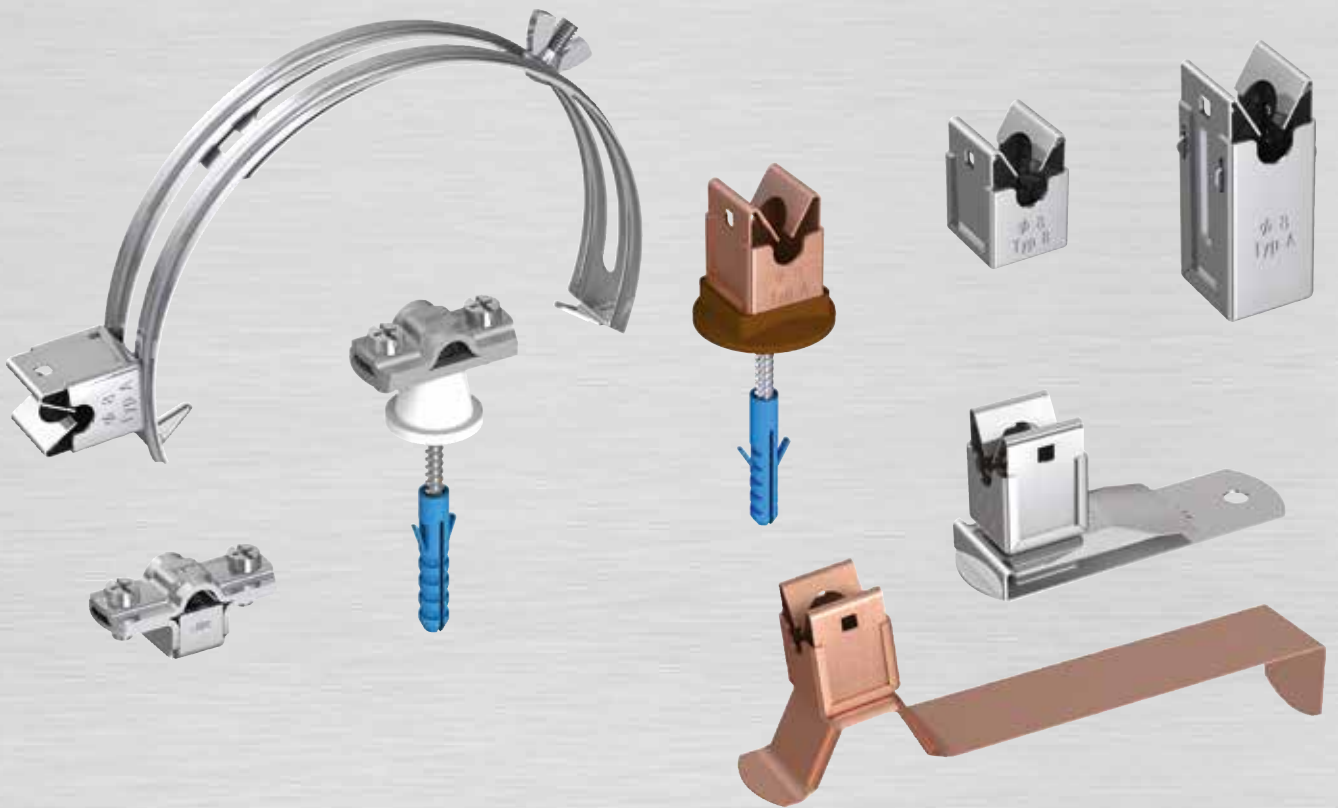



## Niro-Clip conductor fastener system

The **original-Niro-Clip**, the first stainless steel Clip in lightning protection, is a multifunctional fastener system for all round conductor attachments to roofs and walls.

Since its invention by J.PRÖPSTER in 1984, the Niro-Clip has been extremely successful. The unique construction of the patented original Niro-Clip has many benefits.

### Benefits:

- Maximal mechanical strength.
- 100% weather resistant.
- Easy handling: simply push in the round conductor and it is secured as if it were screwed on.

**Proven millions  
of times  
since 1984**

### Example of application:

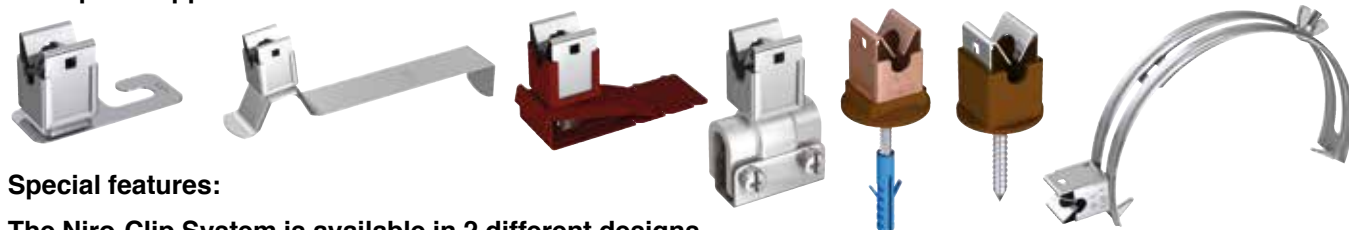

### Special features:

The Niro-Clip System is available in 2 different designs.

- **Niro-Clip Type A** = **fixed conductor leading** - round conductor is clamped down as securely as if it were screwed (e.g. Ord. no. 111 001).
- **Niro-Clip Type B** = **loose conductor leading** - round conductor can shift inside fastener e.g. when round conductor expands. (e.g. Ord. no. 110 090).

### Note:

Round conductor can be removed with straightening tool (Ord. no. 110 230 page 173) or Niro-Clip opener (Ord. no. 1049; page 65)



## Niro-Clip conductor fastener (J.P. patent)



Ord. no. 111 001



Ord. no. 110 090



**Niro-Clip type B:**  
Rounded edges -  
Improved loose conductor leading

## Niro-Clip conductor fastener

for fixing round conductor to walls. Fastener and base made of metal.

<b>Type A = fixed conductor leading</b>					
Specification fastener / base	Bore / thread	Fit *)	PU	Ord. no.	
Stainless steel V2A / stainless steel V2A	ø 6.5 mm	ø 8 mm / type A	200	111 001	
Stainless steel V2A coppered / copper	ø 6.5 mm	ø 8 mm / type A	200	111 002	
Stainless steel V2A / stainless steel V2A	M6	ø 8 mm / type A	200	111 005	
Stainless steel V2A coppered / copper	M6	ø 8 mm / type A	200	111 006	
Stainless steel V2A / stainless steel V2A	ø 7 mm	ø 10 mm / type A	200	110 090 S	
Stainless steel V2A / stainless steel V2A	M6	ø 10 mm / type A	200	110 095 S	

Conductor height Niro-Clip type A: 15 mm

<b>Type B = loose conductor leading</b>					
Specification fastener / base	Bore / thread	Fit *)	PU	Ord. no.	
Stainless steel V2A / stainless steel V2A	ø 6.5 mm	ø 8 mm / type B	200	110 090	
Stainless steel V2A coppered / copper	ø 6.5 mm	ø 8 mm / type B	200	110 091	
Stainless steel V2A / stainless steel V2A	M6	ø 8 mm / type B	200	110 095	
Stainless steel V2A coppered / copper	M6	ø 8 mm / type B	200	110 096	

Conductor height Niro-Clip type B: 14 mm

For washers and spacers see page 67

\*) **Type A (fl)** = fixed conductor leading; **Type B (ll)** = loose conductor leading





**Niro-Clip conductor fastener -high version-** (Height: up to 36 mm)  
for fixing round conductors to walls. Fastener and base made of metal.

<b>Type A = fixed conductor leading</b>				
Specification fastener / base	Bore / thread	Fit *)	PU	Ord. no.
Stainless steel V2A / stainless steel V2A	ø 6.5 mm	ø 8 mm / type A	100	111 501
Stainless steel V2A / stainless steel V2A	M6	ø 8 mm / type A	100	111 503
Stainless steel V2A / stainless steel V2A	ø 7 mm	ø 10 mm / type A	100	111 509
Stainless steel V2A / stainless steel V2A	M6	ø 10 mm / type A	100	111 510

Conductor height Niro-Clip high version type A: 36 mm

<b>Type B = loose conductor leading</b>				
Specification fastener / base	Bore / thread	Fit *)	PU	Ord. no.
Stainless steel V2A / stainless steel V2A	ø 6.5 mm	ø 8 mm / type B	100	111 505
Stainless steel V2A / stainless steel V2A	M6	ø 8 mm / type B	100	111 507

Conductor height Niro-Clip high version type B: 35 mm

**Niro-Clip conductor fastener** with washer, screw and ø 8 mm dowel.

<b>Type A = fixed conductor leading</b>				
Specification fastener / base	Height	Fit *)	PU	Ord. no.
Stainless steel V2A / stainless steel V2A	18 mm	ø 8 mm / type A	100	111 031
Stainless steel V2A coppered / copper	18 mm	ø 8 mm / type A	100	111 032
Stainless steel V2A / stainless steel V2A	42 mm	ø 8 mm / type A	50	110 500
Stainless steel V2A coppered / copper	42 mm	ø 8 mm / type A	50	110 502

<b>Type B = loose conductor leading</b>				
Specification fastener / base	Height	Fit *)	PU	Ord. no.
Stainless steel V2A / stainless steel V2A	17 mm	ø 8 mm / type B	100	110 080
Stainless steel V2A coppered / copper	17 mm	ø 8 mm / type B	100	110 081
Stainless steel V2A / stainless steel V2A	41 mm	ø 8 mm / type B	50	110 501
Stainless steel V2A coppered / copper	41 mm	ø 8 mm / type B	50	110 503

**Niro-Clip cover cap**, additional locking and edge protection.

Specification	PU	Ord. no.
Stainless steel V2A	100	111 000
Stainless steel V2A coppered	100	110 999

**Niro-Clip opener** - to open and loosen the wire from the Niro-Clip. Bending and straightening function for soft materials (e.g. aluminium up to ø 8 mm).

Specification	Weight	Fit	PU	Ord. no.
Niro-Clip opener, polyamide with bi-hexagonal wrench width 13/17	54 g	ø 8 mm	1	110 230

## Niro-Clip conductor fastener



Ord. no. 111 501

## Niro-Clip conductor fastener



Ord. no. 111 031

Ord. no. 110 502

## Niro-Clip cover cap



Ord. no. 111 000

Example of application:



## Niro-Clip opener



Ord. no. 110 230

\*) **Type A (fl)** = fixed conductor leading; **Type B (ll)** = loose conductor leading



## Niro-Clip conductor fastener



Ord. no. 111 003    Ord. no. 111 004

## Niro-Clip conductor fastener

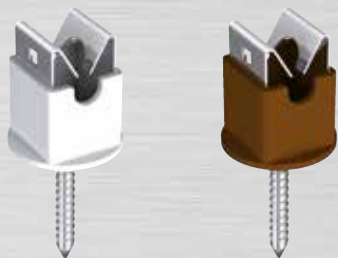

Ord. no. 111 029    Ord. no. 111 030

## Screw cap conductor fastener (SK)

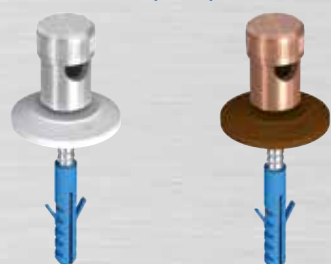

Ord. no. 1010    Ord. no. 1014

## Plastic conductor fastener



Ord. no. 1152    Ord. no. 1154

**Niro-Clip conductor fastener**, for fixing round conductors to walls.  
Fastener made of stainless steel V2A, base made of polyamide 6 (PA 6).

Specification fastener / base	Bore / thread	Fit	PU	Ord. no.
Stainless steel V2A / PA 6-base grey	ø 7 mm	ø 8 mm	100	111 003
Stainless steel V2A / PA 6-base brown	ø 7 mm	ø 8 mm	100	111 004
Stainless steel V2A / PA 6-base grey	M6	ø 8 mm	100	111 007

**Niro-Clip conductor fastener with screw**, base made of polyamide 6 (PA 6).

Specification fastener / base	Height	Fit	PU	Ord. no.
Stainless steel V2A / PA 6 grey	18 mm	ø 8 mm	100	111 029
Stainless steel V2A / PA 6 brown	18 mm	ø 8 mm	100	111 030

**Screw cap conductor fastener SK** with fastening element and cover rosette, designed for round conductor ø 8 mm for quick and safe wire attachment to walls.

Specification	Height	Fit	PU	Ord. no.
Aluminium	17 mm	ø 8 mm	100	1010
Aluminium	27 mm	ø 8 mm	100	1011
Copper-alloy	17 mm	ø 8 mm	100	1014
Copper-alloy	27 mm	ø 8 mm	100	1015

Also available without screw and dowel.

**Plastic conductor fastener -discontinued model-** for fixing round conductors ø 8 mm to walls. Conductor fastener for low load, made of nylon.

Specification	Height	Fit	PU	Ord. no.
Grey	M6 thread	ø 8 mm	100	1152
Grey	M8 thread	ø 8 mm	100	1153
Copper-coloured	M6 thread	ø 8 mm	100	1158
Copper-coloured	M8 thread	ø 8 mm	100	1159
Grey	M6 thread	ø 8 mm	100	1150
Copper-coloured	M6 thread	ø 8 mm	100	1151
Grey	Dowel 6 x 35 mm	ø 8 mm	100	1154
Grey	Dowel 8 x 35 mm	ø 8 mm	100	1155



## Fastener

Specification	Hole spacing	Fit	Material	PU	Ord. no.
with two bore holes elongated hole ø 6.5 x 8.5 mm	28 mm	ø 8-10 mm	Aluminium	100	110 001
	38 mm	ø 8-10 mm	Aluminium	100	110 002
	38 mm	ø 16 mm	Aluminium	100	110 003
	28 mm	ø 8-10 mm	Copper	100	110 004
	28 mm	ø 8-10 mm	Stainless steel V2A	100	110 006
	38 mm	ø 16 mm	Stainless steel V2A	100	110 007
	38 mm	flat 30 mm	Aluminium	100	110 008
Fastener for strip (flat 30 mm), for fixing directly to walls			Stainless steel V2A	100	110 015

Specification	Material	PU	Ord. no.
with one bore hole ø 6.5 mm for flush-mounted installation of conductors ø 8 - 11 mm	Stainless steel V2A	100	110 009
	Copper	100	110 010
with plastic dowel (ø 6 mm) for flush-mounted installation of conductors ø 8 - 11 mm	Stainless steel V2A	100	110 014

## Washers and spacers

Specification	Length	Material	PU	Ord. no.
Washer		Plastic grey	100	1042
Washer		Plastic brown	100	1046
Washer for Niro-Clip		Plastic grey	100	1047
Washer for Niro-Clip		Plastic brown	100	1048
Washer		Stainless steel V2A	100	111 049
Spacer		Plastic grey	100	111 047
Spacer		Plastic brown	100	111 048
Dowel for composite head insulation systems	90 mm	Plastic white	25	110 097
	50 mm	Plastic white	50	110 098

Screws on page 174.

## Fastener



Wall and roof conductor holders

## Accessories





## Conductor fastener



Ord. no. 110 171

Ord. no. 1034

Ord. no. 1132

## Conductor fastener



Ord. no. 110 069

Ord. no. 110 160

Ord. no. 1137

## Conductor fastener with fixed pin



Ord. no. 2030

## with loose pin



Ord. no. 110 045

## Conductor fastener



Ord. no. 110 099

Ord. no. 110 056

Ord. no. 110 034

**Conductor fastener** for round conductor  $\varnothing$  8-10 mm, mounted with screws M6 V2A, washer or spacer, fastening screw and dowel  $\varnothing$  8 mm.

Specification	Fastener	Inner thread	Height	PU	Ord. no.
Zinc die-cast	Steel, hot galv.	M8	24 mm	100	110 171
Zinc die-cast	Stainless steel V2A	M8	24 mm	100	110 180
Red brass	Copper	M8	24 mm	100	110 172
Steel, hot galv. - plastic	Steel, hot galv.		20 mm	100	1034
Aluminium - plastic	Aluminium		20 mm	100	1033
Copper - plastic	Copper		20 mm	100	1032
Stainless steel V2A - plastic	Stainless steel V2A		20 mm	100	1031
Stainless steel V2A	Stainless steel V2A		15 mm	100	1132

**Conductor fastener** for round conductor  $\varnothing$  8-10 mm, mounted with screws M6 V2A.

Specification	Fastener	Inner thread	Height	PU	Ord. no.
Zinc die-cast	Steel, hot galvanized	M6	20 mm	100	110 069
Zinc die-cast	Steel, hot galvanized	M8	20 mm	100	110 071
Zinc die-cast	Stainless steel V2A	M8	20 mm	100	110 189
Zinc die-cast with washer	Steel, hot galvanized	M6	23 mm	100	110 160
Zinc die-cast with washer	Stainless steel V2A	M6	23 mm	100	110 190
Zinc die-cast with washer	Steel, hot galvanized	M8	23 mm	100	110 161
Zinc die-cast with washer	Stainless steel V2A	M8	23 mm	100	110 191
Red brass	Copper	M8	20 mm	100	110 072
Stainless steel V2A	Stainless steel V2A	M8	15 mm	100	1137

**Conductor fastener** with **fixed pin** or **loose pin** for round conductor  $\varnothing$  8-10 mm, mounted with screws M6 V2A

Specification with fixed pin (discontinued model)	Length	PU	Ord. no.
Copper-alloy	100 mm	100	1035
Copper-alloy	120 mm	100	1036
Copper-alloy	150 mm	50	1037
Stainless steel V2A	100 mm	50	2030

Specification with loose pin	Length	PU	Ord. no.
Aluminium with steel pin	70 mm	100	110 270
Aluminium with steel pin	100 mm	100	110 271
Aluminium with steel pin	150 mm	50	110 272
Steel, hot galvanized with steel pin	70 mm	100	110 050
Steel, hot galvanized with steel pin	100 mm	100	110 045
Steel, hot galvanized with steel pin	150 mm	50	110 047
Stainless steel V2A with stainless steel pin	100 mm	100	110 276
Stainless steel V2A with stainless steel pin	150 mm	50	110 277
Copper with stainless steel pin	100 mm	100	110 280
Copper with stainless steel pin	150 mm	50	110 281

**Conductor fastener** for insulated walls with insulation thickness of 40-170 mm.

Specification	Insulation thickness	Fit	PU	Ord. no.
<b>Conductor fastener *)</b>				
Niro-Clip stainless steel V2A	up to 60 mm	$\varnothing$ 8 mm /type A	50	110 030
Niro-Clip stainless steel V2A	up to 120 mm	$\varnothing$ 8 mm /type A	50	110 056
Niro-Clip stainless steel V2A	up to 170 mm	$\varnothing$ 8 mm /type B	50	110 056 S3
Niro-Clip stainless steel V2A with dowel	min. 50 mm	$\varnothing$ 8 mm /type B	50	110 099
Fastener aluminium	up to 60 mm	$\varnothing$ 8 mm	50	110 034
Fastener aluminium	up to 170 mm	$\varnothing$ 8 mm	50	110 034 S3
<b>Rod holder</b>				
Fastener aluminium	up to 170 mm	$\varnothing$ 16 mm	50	110 038 S1

Fastener for additional insulation thicknesses available on request!

\*) **Type A (fl)** = fixed conductor leading; **Type B (ll)** = loose conductor leading



**Downpipe conductor fastener with beading** for  $\varnothing$  8 mm, to install conductors behind downpipes. **Benefit:** No additional wall fastener required! Fast, clean installation without drilling.

Specification	Diameter of pipe	PU	Ord. no.
<b>With bolt and nut M6</b>			
Steel, hot galvanized	$\varnothing$ 80 mm	25	111 222
Steel, hot galvanized	$\varnothing$ 100 mm	25	111 225
Steel, hot galvanized	$\varnothing$ 120 mm	25	111 227
Copper	$\varnothing$ 80 mm	25	111 232
Copper	$\varnothing$ 100 mm	25	111 235
Copper	$\varnothing$ 120 mm	25	111 237
Aluminium	$\varnothing$ 100 mm	25	111 265
Aluminium	$\varnothing$ 110 mm	25	111 266
Aluminium	$\varnothing$ 120 mm	25	111 267
<b>With bolt M6 and through-hole thread (without nut)</b>			
Steel, hot galvanized	$\varnothing$ 80 mm	25	111 222 G
Steel, hot galvanized	$\varnothing$ 100 mm	25	111 225 G
Steel, hot galvanized	$\varnothing$ 120 mm	25	111 227 G
Copper	$\varnothing$ 80 mm	25	111 232 G
Copper	$\varnothing$ 100 mm	25	111 235 G
Copper	$\varnothing$ 120 mm	25	111 237 G
Aluminium	$\varnothing$ 100 mm	25	111 265 G
Aluminium	$\varnothing$ 110 mm	25	111 266 G
Aluminium	$\varnothing$ 120 mm	25	111 267 G

Additional diameters on request!

**With snap-mounting** **NEW:** also for diameter 85 mm and 95 mm

Steel, hot galvanized	$\varnothing$ 80/85/90/95/100/110/120 mm	25	110 255
Aluminium	$\varnothing$ 80/85/90/95/100/110/120 mm	25	110 256
Copper	$\varnothing$ 80/85/90/95/100/110/120 mm	25	110 257
Stainless steel V2A	$\varnothing$ 80/85/90/95/100/110/120 mm	25	110 258

**Universal downpipe conductor fastener**, to install conductors behind downpipes. **Benefit:** No additional wall fastener required! Fast, clean installation without drilling.

Specification pipe bracket / tensioning strip	Diameter of pipe	PU	Ord. no.
Stainless steel V2A / stainless steel V2A	$\varnothing$ 60-120 mm	50	110 250
Stainless steel V2A / stainless steel V2A	$\varnothing$ 80-150 mm	50	110 251
Stainless steel V2A / <b>without strip</b>	--	200	110 249
Stainless steel V2A/coppered / Copper-tin-alloy	$\varnothing$ 60-120 mm	50	110 252
Stainless steel V2A/coppered / Copper-tin-alloy	$\varnothing$ 80-150 mm	50	110 253

**Stainless steel - tensioning strap** in practical cut-to length packaging

Specification	Length	Fit	PU	Ord. no.
Strap stainless steel V2A	25 m	15 x 0.4 mm	1	110 248

**Downpipe conductor fastener with beading** for  $\varnothing$  8-10 mm, to install conductors behind downpipes. **Benefit:** No additional wall fastener required! Fast, clean installation without drilling.

Specification	Dimensions of pipe	PU	Ord. no.
Steel, hot galvanized	80 x 80 mm	25	911 654
Steel, hot galvanized	100 x 100 mm	25	911 280
Aluminium	80 x 80 mm	25	911 654 S
Aluminium	100 x 100 mm	25	911 280 S
Copper	80 x 80 mm	25	913 610
Copper	100 x 100 mm	25	913 611

Additional dimensions on request.

**Conductor fastener** for insulated mounting of earth lead-in rods and terminal lugs to the downpipes.

Specification	Fit of holder	PU	Ord. no.
Stainless steel V2A	$\varnothing$ 16 mm	50	111 396
<b>Benefits:</b> universally mountable to the downpipe conductor fasteners with hexagonal screw M8 (e.g. Ord. no. 111 213, 111 120 or 111 391).	$\varnothing$ 8-10 mm	50	111 397
	fl. 30 mm	50	111 398
	$\varnothing$ 13 mm	50	111 399

**Note:** For pipe clamps for fixing the conductor fastener to the downpipe on page 109

## Downpipe conductor fastener with beading

with M6 nut



Ord. no. 111 265

with M6 through-hole thread



Ord. no. 111 225 G

with snap-mounting



Ord. no. 110 256

## Universal downpipe conductor fastener



Ord. no. 110 250

Ord. no. 110 249

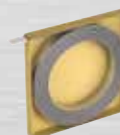

Ord. no. 110 248

## Downpipe conductor fastener with beading



Ord. no. 911 280

## Conductor fastener



Ord. no. 111 396

Ord. no. 111 398

Example of application:





## Rod holder

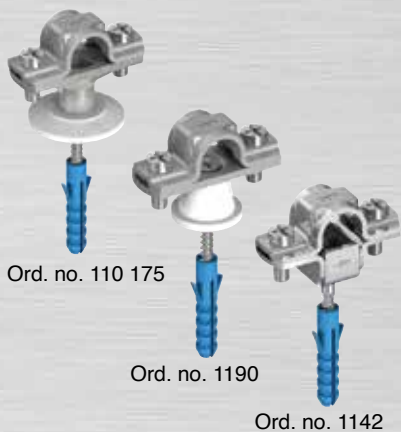

Ord. no. 110 175

Ord. no. 1190

Ord. no. 1142

## Rod holder



Ord. no. 110 073

Ord. no. 110 164

Ord. no. 1147

## Rod holder with fixed pin



Ord. no. 1195

## with loose pin



Ord. no. 110 279

## Conductor fastener



Ord. no. 110 265

**Rod holder** for fixing air termination rods and earth lead-in rods, with screws M6 V2A, washer or spacer, fixing screw and dowel ø 8 mm.

Specification	Fastener	Fem. thread	Fit	Height	PU	Ord. no.
Zinc die-cast	Steel, hot galvanized	M8	ø16 mm	24 mm	50	110 175
Zinc die-cast	Stainless steel V2A	M8	ø16 mm	24 mm	50	110 182
Red brass	Copper	M8	ø16 mm	24 mm	50	110 176
Zinc die-cast	Steel, hot galvanized	M8	ø13 mm	24 mm	50	110 187
Steel, hot galv. -plastic	Steel, hot galvanized		ø16 mm	20 mm	100	1190
Aluminium - plastic	Aluminium		ø16 mm	20 mm	100	1187
Copper - plastic	Copper		ø16 mm	20 mm	100	1188
Stainless steel V2A -plastic	Stainless steel V2A		ø16 mm	20 mm	100	1189
Steel, hot galv. -plastic	Steel, hot galvanized		ø13 mm	20 mm	100	1194
Stainless steel V2A	Stainless steel V2A		ø16 mm	15 mm	100	1142

**Rod holder** for fixing air termination rods and earth lead-in rods, with screws M6 V2A.

Specification	Fastener	Fem. thread	Fit	Height	PU	Ord. no.
Zinc die-cast	Steel, hot galvanized	M6	ø16 mm	20 mm	100	110 073
Zinc die-cast	Stainless steel V2A	M6	ø16 mm	20 mm	100	110 196
Zinc die-cast	Steel, hot galvanized	M8	ø16 mm	20 mm	100	110 075
Zinc die-cast	Stainless steel V2A	M8	ø16 mm	20 mm	100	110 197
Zinc die-cast with washer	Steel, hot galvanized	M6	ø16 mm	23 mm	100	110 164
Zinc die-cast with washer	Stainless steel V2A	M6	ø16 mm	23 mm	100	110 198
Zinc die-cast with washer	Steel, hot galvanized	M8	ø16 mm	23 mm	100	110 165
Zinc die-cast with washer	Stainless steel V2A	M8	ø16 mm	23 mm	100	110 199
Red brass	Copper	M8	ø16 mm	20 mm	100	110 076
Zinc die-cast	Steel, hot galvanized	M8	ø13 mm	20 mm	100	110 087
Stainless steel V2A	Stainless steel V2A	M8	ø16 mm	15 mm	100	1147

**Rod holder** with **fixed pin** or **loose pin**, for fixing air termination rods and earth lead-in rods, mounted with screws M6 V2A.

Specification with fixed pin (discontinued model)	Fit	Length	PU.	Ord. no.
Steel, hot galvanized	ø16 mm	100 mm	50	1195
Steel, hot galvanized	ø16 mm	150 mm	50	1196

Specification with loose pin	Fit	Length	PU	Ord. no.
Steel, hot galvanized with steel pin	ø16 mm	100 mm	100	110 046
Steel, hot galvanized with steel pin	ø16 mm	150 mm	50	110 048
Stainless steel V2A mit stainless steel pin	ø16 mm	100 mm	100	110 278
Stainless steel V2A mit stainless steel pin	ø16 mm	150 mm	50	110 279
Copper with stainless steel pin	ø16 mm	100 mm	100	110 282
Copper with stainless steel pin	ø16 mm	150 mm	50	110 283

**Conductor fastener** for fixing cables ø 10.5 - 14 mm, with button head screw V2A and ø 8 mm dowel.

Specification	Fit	PU	Ord. no.
Stainless steel V2A	ø 10.5 - 14 mm	100	110 265



## Tape conductor holder for 30 mm wide flat strips.

**Benefit:** less work - insert the strip, bend the lug - ready

Specification	Fit	PU	Ord. no.
Stainless steel V2A with screw and dowel ø 8 mm	fl. 30 mm	100	1178
Stainless steel V2A	fl. 30 mm	100	1178 S

Example of application:

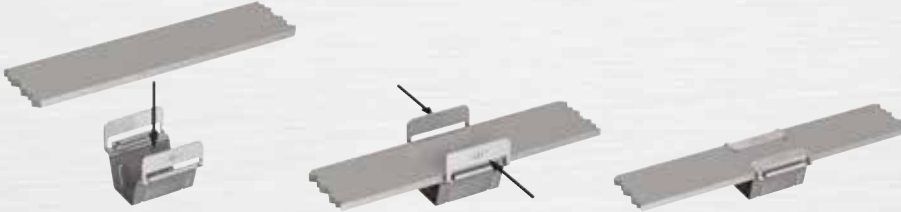

## Tape conductor holder for 30 mm wide flat strip, with screws M6 V2A, washer or base, fixing screw and dowel ø 8 mm.

Specification	Fastener	Fem. thread	Height	PU	Ord. no.
Zinc die-cast	Steel, hot galvanized	M8	24 mm	100	110 178
Zinc die-cast	Stainless steel V2A	M8	24 mm	100	110 181
Steel, hot galvanized - plastic	Steel, hot galvanized		20 mm	100	1183
Aluminium - plastic	Aluminium		20 mm	100	1185
Stainless steel V2A - plastic	Stainless steel V2A		20 mm	100	1184
Stainless steel V2A	Stainless steel V2A		15 mm	100	1121

For 40 mm wide flat strips on request.

## Tape conductor holder for 30 mm wide flat strip, with screws M6 V2A.

Specification	Fastener	Fem. thread	Height	PU	Ord. no.
Zinc die-cast	Steel, hot galvanized	M6	20 mm	100	110 077
Zinc die-cast	Steel, hot galvanized	M8	20 mm	100	110 078
Zinc die-cast with base	Steel, hot galvanized	M6	23 mm	100	110 162
Zinc die-cast with base	Stainless steel V2A	M6	23 mm	100	110 194
Zinc die-cast with base	Steel, hot galvanized	M8	23 mm	100	110 163
Zinc die-cast with base	Stainless steel V2A	M8	23 mm	100	110 195
Stainless steel V2A	Stainless steel V2A	M8	15 mm	100	1128

For 40 mm wide flat strips on request.

## Tape conductor holder with button head screw V2A and dowel ø 8 mm.

Specification	Height	Fit	PU	Ord. no.
Steel, hot galvanized	15 mm	fl. 30 mm	100	1180
Steel, hot galvanized	15 mm	fl. 40 mm	100	2037
Copper	15 mm	fl. 40 mm	100	2039
Stainless steel V2A	15 mm	fl. 30 mm	100	1181

## Tape conductor holder for wall mounting, with screw M8 and clamping bracket.

Specification	Slot width	Distance to wall	PU	Ord. no.
Steel, hot galvanized	10 mm	18 mm	50	911 314
Copper	10 mm	18 mm	50	911 576
Stainless steel V2A	10 mm	18 mm	50	911 575

## Tape conductor holder (J+P patent)

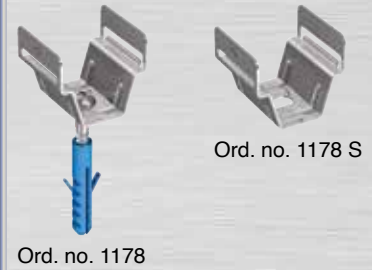

Ord. no. 1178 S

Ord. no. 1178

## Tape conductor holder

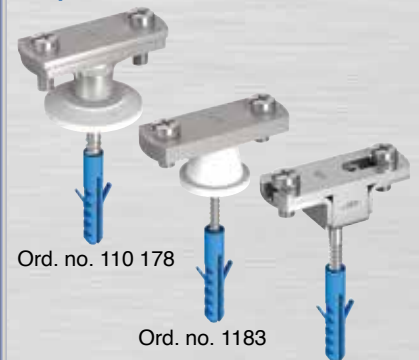

Ord. no. 110 178

Ord. no. 1183

Ord. no. 1121

## Tape conductor holder



Ord. no. 110 077

Ord. no. 110 162

Ord. no. 1128

## Tape conductor holder



Ord. no. 1181

## Tape conductor holder



Ord. no. 911 314



## Roof conductor holder with clamping bracket & Niro-Clip



Ord. no. 111 010



Ord. no. 111 525

## Roof conductor holder with Niro-Clip for thin aluminium roof shingles



Ord. no. 111 010 S

### PRÖ COLOR

## Roof conductor holder with clamping bracket & Niro-Clip



Ord. no. 111 010 az



Ord. no. 111 525 ro

## Roof conductor holder



Ord. no. 1028



Ord. no. 110 517

## Roof conductor holder system Niro-Clip

Roof conductor holder with clamping bracket, for bitumen shingles and slate roofs or for tiles with large clamping range.

Specification	Fixed conductor leading	Clamp. range	Fit	PU	Ord. no.
<b>Base</b>	<b>Niro-Clip type A</b>				
Stainless steel V2A	Stainless steel V2A	up to 5 mm	ø 8 mm	100	111 010
Stainless steel V2A	Stainless steel V2A	up to 18 mm	ø 8 mm	100	111 525
Copper	Stainless steel /coppered	up to 5 mm	ø 8 mm	100	111 012
Copper	Stainless steel /coppered	up to 18 mm	ø 8 mm	100	111 526

Specification	Loose conductor leading	Clamp. range	Fit	PU	Ord. no.
<b>Base</b>	<b>Niro-Clip type B</b>				
Stainless steel V2A	Stainless steel V2A	up to 5 mm	ø 8 mm	100	111 011
Stainless steel V2A	Stainless steel V2A	up to 18 mm	ø 8 mm	100	111 527
Copper	Stainless steel /coppered	up to 5 mm	ø 8 mm	100	111 013
Copper	Stainless steel /coppered	up to 18 mm	ø 8 mm	100	111 528

Roof conductor holder with cranked clamping piece and undercut for secure attachment to thin aluminium roof shingles.

Specification	Fixed conductor leading	Fit	PU	Ord. no.
<b>Base</b>	<b>Niro-Clip type A</b>			
Stainless steel V2A	Stainless steel V2A	ø 8 mm	100	111 010 S

Specification	Loose conductor leading	Fit	PU	Ord. no.
<b>Base</b>	<b>Niro-Clip type B</b>			
Stainless steel V2A	Stainless steel V2A	ø 8 mm	100	111 010 S1

### PRÖ-COLOR Roof conductor holder

for bitumen shingles and slate roofs or for tiles with large clamping range.

Specification	Fixed conductor leading	Clamp. range	Fit	PU	Ord. no.
<b>Base</b>	<b>Niro-Clip type A</b>				
Steel, hot galv. /coated	Stainless steel V2A	up to 5 mm	ø 8 mm	100	111 010 az
Steel, hot galv. /coated	Stainless steel V2A	up to 18 mm	ø 8 mm	100	111 525 ro
Steel, hot galv. /coated	Stainless steel V2A	up to 18 mm	ø 8 mm	100	111 525 az

Specification	Loose conductor leading	Clamp. range	Fit	PU	Ord. no.
<b>Base</b>	<b>Niro-Clip type B</b>				
Steel, hot galv. /coated	Stainless steel V2A	up to 5 mm	ø 8 mm	100	111 011 az
Steel, hot galv. /coated	Stainless steel V2A	up to 18 mm	ø 8 mm	100	111 527 ro
Steel, hot galv. /coated	Stainless steel V2A	up to 18 mm	ø 8 mm	100	111 527 az

**Specifications:** ● ro - colour of the conductor holder: red brown  
● az - colour of the conductor holder: anthracite

Roof conductor holder suitable for all tile shapes; for ø 8 mm round conductor; to be used on the ridge and the roof surface, bore hole ø 12 mm.

Specification	Fastener *)	Height	Fit	PU	Ord. no.
Grommet (TPE-soft)	Niro-Clip stainless steel/ type A	23 mm	ø 8 mm	100	1028
Grommet (TPE-soft)	Niro-Clip stainless steel/ type B	22 mm	ø 8 mm	100	1027
Grommet (TPE-soft)	Niro-Clip stainless steel/ type A	44 mm	ø 8 mm	50	110 517

\*) **Type A (fl)** = fixed conductor leading; **Type B (ll)** = loose conductor leading



## Roof conductor holder with clamping bracket (clamping range up to 5 mm) for slate roofs; especially well-suited for later installation!

Specification	Fixed conductor leading	Length	Fit	PU	Ord. no.
<b>Base</b>	<b>Niro-Clip type A</b>				
Stainless steel V2A with teeth	Stainless steel V2A	180 mm	ø 8 mm	200	111 033
Stainless steel V2A without teeth	Stainless steel V2A	180 mm	ø 8 mm	200	111 512
Copper with teeth	Stainless steel/CC	180 mm	ø 8 mm	200	111 035
<b>Specification</b>	<b>Loose conductor leading</b>	<b>Length</b>	<b>Fit</b>	<b>PU</b>	<b>Ord. no.</b>
<b>Base</b>	<b>Niro-Clip type B</b>				
Stainless steel V2A with teeth	Stainless steel V2A	180 mm	ø 8 mm	200	111 511
Stainless steel V2A without teeth	Stainless steel V2A	180 mm	ø 8 mm	200	111 513
Copper with teeth	Stainless steel/CC	180 mm	ø 8 mm	200	111 516

## PRÖ-COLOR Roof conductor holder (clamping range up to 5 mm) for slate roofs; especially well-suited for later installation!

Specification	Niro-Clip V2A	Length	Fit	PU	Ord. no.
<b>Base</b>	<b>Type A - fixed conductor leading</b>				
Steel, hot galvanized/coated with teeth	Type A - fixed conductor leading	180 mm	ø 8 mm	200	111 033 az
Steel, hot galvanized/coated with teeth	Type B - loose conductor leading	180 mm	ø 8 mm	200	111 511 az

**Specification:** ● az - color of the conductor holder in anthracite

## Roof conductor holder, for direct clamping to flat roof tiles, sheets and ridge tiles. Clamping range 9-15 mm, clamp by twisting holder.

Specification	Fixed conductor leading	Height	Fit	PU	Ord. no.
<b>Base</b>	<b>Niro-Clip type A</b>				
Stainless steel V2A	Stainless steel V2A	30 mm	ø 8 mm	50	111 550
Copper	Stainless steel /coppered	30 mm	ø 8 mm	50	111 552
<b>Specification</b>	<b>Loose conductor leading</b>	<b>Height</b>	<b>Fit</b>	<b>PU</b>	<b>Ord. no.</b>
<b>Base</b>	<b>Niro-Clip type B</b>				
Stainless steel V2A	Stainless steel V2A	29 mm	ø 8 mm	50	111 551
Copper	Stainless steel /coppered	29 mm	ø 8 mm	50	111 553

## Conductor fastener for universal use, with standing seam clamp, clamping range 1-8 mm.

Specification	Niro-Clip *)	Fit	PU	Ord. no.
<b>Bottom part</b>	<b>Niro-Clip *)</b>			
Steel, hot galvanized	Stainless steel V2A/ type B	ø 8 mm	50	913 732
Copper	Stainless steel V2A/coppered / type B	ø 8 mm	50	913 733
Stainless steel V2A	Stainless steel V2A/ type B	ø 8 mm	50	913 734
Aluminium	Stainless steel V2A/ type B	ø 8 mm	50	913 420

## Roof conductor holder with clamping bracket & Niro-Clip



Ord. no. 111 033

## PRÖ COLOR Roof conductor holder with clamping bracket & Niro-Clip



Ord. no. 111 033 az

## Roof conductor holder with Niro-Clip



Ord. no. 111 550

## Conductor fastener with Niro-Clip



Ord. no. 913 420

\*) **Type A (fl)** = fixed conductor leading; **Type B (ll)** = loose conductor leading



## Roof conductor holder



Ord. no. 111 019

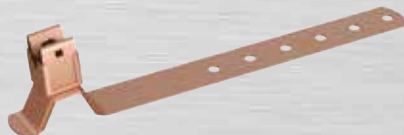

Ord. no. 111 020

Wall and roof conductor holders

## PRÖ COLOR

### Roof conductor holder with Niro-Clip

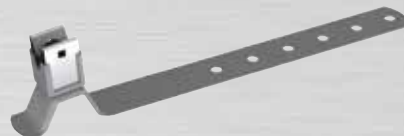

Ord. no. 111 019 az



Ord. no. 111 019 ro

### J.Pröpster patented Roof conductor holder (J.P. patent)



Ord. no. 111 051

Ord. no. 111 052

### Roof conductor holder with screw fastening



Ord. no. 1062

## Roof conductor holder for universal use.

Specification	Type A Fixed conductor leading	Length	Fit	PU	Ord. no.
<b>Bottom part</b>	<b>Niro-Clip</b>				
Stainless steel V2A	Stainless steel V2A	210 mm	ø 8 mm	100	111 019
Stainless steel V2A	Stainless steel V2A	280 mm	ø 8 mm	100	111 015
Stainless steel V2A	Stainless steel V2A	410 mm	ø 8 mm	50	111 535
Copper	Stainless steel V2A/coppered	210 mm	ø 8 mm	100	111 020
Copper	Stainless steel V2A/coppered	280 mm	ø 8 mm	100	111 016
Copper	Stainless steel V2A/coppered	410 mm	ø 8 mm	50	111 537
Specification	Type B Loose conductor leading	Length	Fit	PU	Ord. no.
<b>Bottom part</b>	<b>Niro-Clip</b>				
Stainless steel V2A	Stainless steel V2A	210 mm	ø 8 mm	100	111 540
Stainless steel V2A	Stainless steel V2A	280 mm	ø 8 mm	100	111 541
Stainless steel V2A	Stainless steel V2A	410 mm	ø 8 mm	50	111 536
Copper	Stainless steel V2A/coppered	210 mm	ø 8 mm	100	111 545
Copper	Stainless steel V2A/coppered	280 mm	ø 8 mm	100	111 546

## PRÖ-COLOR Roof conductor holder for universal use.

Specification	Type A Fixed conductor leading	Length	Fit	PU	Ord. no.
<b>Bottom part</b>	<b>Niro-Clip</b>				
Steel, hot galvanized/coated	Stainless steel V2A	210 mm	ø 8 mm	100	111 019 az
Steel, hot galvanized/coated	Stainless steel V2A	280 mm	ø 8 mm	100	111 015 az
Steel, hot galvanized/coated	Stainless steel V2A	210 mm	ø 8 mm	100	111 019 ro
Steel, hot galvanized/coated	Stainless steel V2A	280 mm	ø 8 mm	100	111 015 ro
Specification	Type B Loose conductor leading	Length	Fit	PU	Ord. no.
<b>Bottom part</b>	<b>Niro-Clip</b>				
Steel, hot galvanized/coated	Stainless steel V2A	210 mm	ø 8 mm	100	111 540 az
Steel, hot galvanized/coated	Stainless steel V2A	280 mm	ø 8 mm	100	111 541 az
Steel, hot galvanized/coated	Stainless steel V2A	210 mm	ø 8 mm	100	111 540 ro
Steel, hot galvanized/coated	Stainless steel V2A	280 mm	ø 8 mm	100	111 541 ro

**Specifications:** ● ro - colour of the conductor holder: red brown  
● az - colour of the conductor holder: anthracite

## Roof conductor holder for universal use. Benefits: one piece, no screws or plastic parts! Quick and easy installation! Made of corrosion resistant stainless steel!

Specification	Length	Fit	PU	Ord. no.
Stainless steel V2A	210 mm	ø 8 mm	200	111 050
Stainless steel V2A	280 mm	ø 8 mm	200	111 051
Stainless steel V2A	110 mm angled	ø 8 mm	200	111 052



## Roof conductor holder for universal use. Support riveted to holder.

Specification	Length	Fit	PU	Ord. no.
Stainless steel V2A	210 mm	ø 8 mm	100	1062
with screw fastening in aluminium	280 mm	ø 8 mm	100	1063
	410 mm	ø 8 mm	50	1064
Copper with screw fastening	210 mm	ø 8 mm	100	1065
	280 mm	ø 8 mm	100	1066
	410 mm	ø 8 mm	50	1067

\*) **Type A (fl)** = fixed conductor leading; **Type B (ll)** = loose conductor leading



## Roof conductor holder for pantiled roofs.

Specification	Type A Fixed conductor leading	Length	Fit	PU	Ord. no.
<b>Bottom part</b>	<b>Niro-Clip</b>				
Stainless steel V2A	Stainless steel V2A	120 mm	ø 8 mm	150	111 023 
Copper	Stainless steel V2A/coppered	120 mm	ø 8 mm	150	111 024
Specification	Type B Loose conductor leading	Length	Fit	PU	Ord. no.
<b>Bottom part</b>	<b>Niro-Clip</b>				
Stainless steel V2A	Stainless steel V2A	120 mm	ø 8 mm	150	111 530 
Copper	Stainless steel V2A/coppered	120 mm	ø 8 mm	150	111 532

## PRÖ-COLOR Roof conductor holder for pantiled roofs.

Specification	Type A Fixed conductor leading	Length	Fit	PU	Ord. no.
<b>Bottom part</b>	<b>Niro-Clip</b>				
Steel, hot galvanized/coated	Stainless steel V2A	120 mm	ø 8 mm	150	111 023 az
Steel, hot galvanized/coated	Stainless steel V2A	120 mm	ø 8 mm	150	111 023 ro
Specification	Type B Loose conductor leading	Length	Fit	PU	Ord. no.
<b>Bottom part</b>	<b>Niro-Clip</b>				
Steel, hot galvanized/coated	Stainless steel V2A	120 mm	ø 8 mm	150	111 530 az
Steel, hot galvanized/coated	Stainless steel V2A	120 mm	ø 8 mm	150	111 530 ro

**Specifications:** ● ro - colour of the conductor holder: red brown  
● az - colour of the conductor holder: anthracite

## Roof conductor holder for easy fitting; simply insert in seam, exert pressure and the support moulds itself to the seam. Aluminium type with stainless steel reinforced trapezoidal section.

Specification	Type A Fixed conductor leading	Length	Fit	PU	Ord. no.
<b>Bottom part</b>	<b>Niro-Clip</b>				
Aluminium	Stainless steel V2A	120 mm	ø 8 mm	150	111 043
Copper	Stainless steel V2A/coppered	120 mm	ø 8 mm	150	111 044
Aluminium	Stainless steel V2A	170 mm	ø 8 mm	100	111 057
Copper	Stainless steel V2A/coppered	170 mm	ø 8 mm	100	111 058
Specification	Type B Loose conductor leading	Length	Fit	PU	Ord. no.
<b>Bottom part</b>	<b>Niro-Clip</b>				
Aluminium	Stainless steel V2A	120 mm	ø 8 mm	150	111 043 S
Copper	Stainless steel V2A/coppered	120 mm	ø 8 mm	150	111 044 S
Aluminium	Stainless steel V2A	170 mm	ø 8 mm	100	111 057 S
Copper	Stainless steel V2A/coppered	170 mm	ø 8 mm	100	111 058 S

## Roof conductor holder for hocking into "ergoldsbacher" interlocking tiles

Specification	Type A Fixed conductor leading	Fit	PU	Ord. no.
<b>Bottom part</b>	<b>Niro-Clip</b>			
Stainless steel V2A	Stainless steel V2A	ø 8 mm	150	111 157 
Copper	Stainless steel V2A/coppered	ø 8 mm	150	111 158

## Roof conductor holder with Niro-Clip



Ord. no. 111 023

## PRÖ-COLOR Roof conductor holder with Niro-Clip



Ord. no. 111 023 az



Ord. no. 111 023 ro

## Roof conductor holder for interlocking tiles



Ord. no. 111 043

## Roof conductor holder for interlocking tiles



Ord. no. 111 157

Wall and roof conductor holders

\*) **Type A (fl)** = fixed conductor leading; **Type B (ll)** = loose conductor leading



## Roof conductor holder with Niro-Clip



Ord. no. 111 027



Ord. no. 111 037

## Roof conductor holder with Niro-Clip



Ord. no. 111 451



Ord. no. 111 436

## Roof conductor holder with Niro-Clip



Ord. no. 1095

## Roof conductor holder with Niro-Clip



Ord. no. 1088

## Roof conductor holder with Niro-Clip



Ord. no. 111 150

**Roof conductor holder** for corrugated sheet roofs,  
for installing round conductors, lengthwise and crosswise conductor leading

Specification		Height	Fit	PU	Ord. no.
<b>Bottom part</b>	<b>Niro-Clip stainless steel</b>				
Stainless steel V2A	Type A fixed conductor leading	18 mm	ø 8 mm	100	111 027
Stainless steel V2A	Type B loose conductor leading	17 mm	ø 8 mm	100	111 045

With high version of Niro-Clip on request.

**Roof conductor holder** for corrugated sheet roofs,  
for installing round conductors, lengthwise and crosswise conductor leading with fixing bore ø 6.5 mm

Specification		Height	Fit	PU	Ord. no.
<b>Bottom part</b>	<b>Niro-Clip stainless steel</b>				
Stainless steel V2A	Type A fixed conductor leading	18 mm	ø 8 mm	100	111 037
Stainless steel V2A	Type B loose conductor leading	17 mm	ø 8 mm	100	111 039

**Roof conductor holder** for hooking into interlocking tiles.

Specification	Specification	Height	Fit	PU	Ord. no.
<b>Bottom part</b>	<b>Niro-Clip Type A</b> Fixed conductor leading				
Stainless steel V2A	Stainless steel V2A	48 mm	ø 8 mm	100	111 451
Copper	Stainless steel V2A/coppered	48 mm	ø 8 mm	100	111 452
<b>Bottom part</b>	<b>Niro-Clip Type B</b> Loose conductor leading				
Stainless steel V2A	Stainless steel V2A	47 mm	ø 8 mm	100	111 453
Copper	Stainless steel V2A/coppered	47 mm	ø 8 mm	100	111 454

Specification	Specification	Height	Fit	PU	Ord. no.
<b>Bottom part</b>	<b>Niro-Clip Type A</b> Fixed conductor leading				
Stainless steel V2A	Stainless steel V2A	48 mm	ø 8 mm	100	111 436
Copper	Stainless steel V2A/coppered	48 mm	ø 8 mm	100	111 434
<b>Bottom part</b>	<b>Niro-Clip Type B</b> Loose conductor leading				
Stainless steel V2A	Stainless steel V2A	47 mm	ø 8 mm	100	111 437
Copper	Stainless steel V2A/coppered	47 mm	ø 8 mm	100	111 431

**Roof conductor holder** as intermediate support  
for installing round conductors to corrugated sheet roofs.

Specification		Fit	PU	Ord. no.
<b>Bottom part</b>	<b>Niro-Clip stainless steel V2A</b>			
Stainless steel V2A	Type A fixed conductor leading	ø 8 mm	100	1095

With high version of Niro-Clip on request.

**Roof conductor holder** for corrugated sheet roofs;  
for installing in the valley of corrugation of corrugated sheet roofs.

Specification		Fit	PU	Ord. no.
<b>Bottom part</b>	<b>Niro-Clip stainless steel V2A</b>			
Stainless steel V2A	Type A fixed conductor leading	ø 8 mm	100	1088

**Roof conductor holder** for slate and bitumen roofs

Specification		Fit	PU	Ord. no.
<b>Bottom part</b>	<b>Niro-Clip stainless steel V2A</b>			
Stainless steel V2A	Type B loose conductor leading	ø 8 mm	100	111 153

\*) **Type A (fl)** = fixed conductor leading; **Type B (ll)** = loose conductor leading



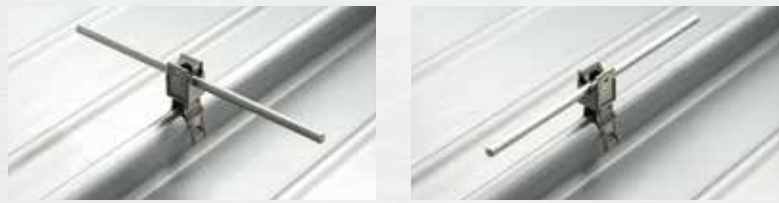

Roof conductor holder for Kalzip, for installing round conductors to Kalzip roof systems (conductor leading lengthwise and crosswise).

Specification		Fit	PU	Ord. no.
<b>Bottom part</b>	<b>Niro-Clip *)</b>			
Stainless steel V2A	Stainless steel type B; crosswise to bead	ø 8 mm	100	111 750 
Stainless steel V2A	Stainless steel type B; lengthwise to bead	ø 8 mm	100	111 750 S



Roof conductor holder for Kalzip, for installing round conductors to Kalzip roof systems (conductor leading lengthwise and crosswise).

Specification		Fit	PU	Ord. no.
<b>Bottom part</b>	<b>Fastener *)</b>			
Aluminium	Niro-Clip stainless steel V2A/ type A	ø 8 mm	25	1309
Aluminium	Niro-Clip stainless steel V2A/ type B	ø 8 mm	25	913 615
Stainless steel V2A	Niro-Clip stainless steel V2A/ type A	ø 8 mm	25	913 616 
Stainless steel V2A	Niro-Clip stainless steel V2A/ type B	ø 8 mm	25	913 617
Aluminium	Double terminal clamp V2A	ø 6-8 mm	25	1309 S
Stainless steel V2A	Double terminal clamp V2A	ø 6-8 mm	25	1308 S 

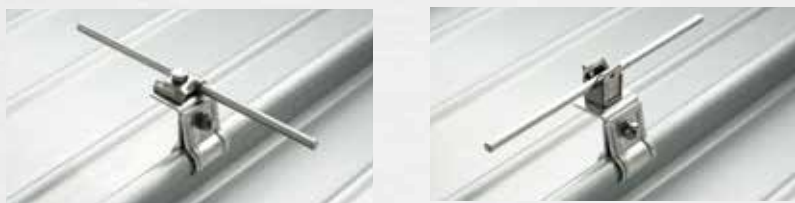

Roof conductor holder for RIB-ROOF 500, for installing round conductors to Rib-Roof 500 roof systems (conductor leading lengthwise and crosswise).

Specification		Fit	PU	Ord. no.
<b>Bottom part</b>	<b>Niro-Clip *)</b>			
Stainless steel V2A	Stainless steel type B; crosswise to bead	ø 8 mm	100	111 760 
Stainless steel V2A	Stainless steel type B; lengthwise to bead	ø 8 mm	100	111 761

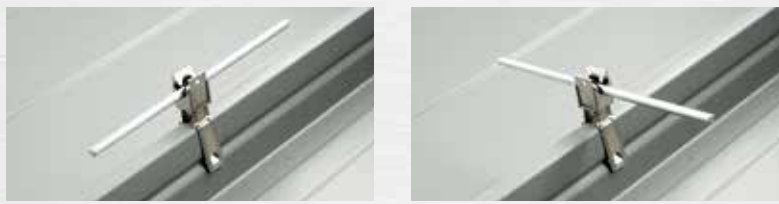

Roof conductor holder for RIB-ROOF 500, for installing round conductors to RIB-ROOF 500 roof systems (conductor leading lengthwise and crosswise).

Specification		Fit	PU	Ord. no.
<b>Bottom part</b>	<b>Fastener *)</b>			
Aluminium	Niro-Clip stainless steel V2A/ type A	ø 8 mm	25	111 764
Aluminium	Niro-Clip stainless steel V2A/ type B	ø 8 mm	25	111 766
Aluminium	Double terminal clamp V2A	ø 6-8 mm	25	111 768
Stainless steel V2A	Double terminal clamp V2A	ø 6-8 mm	25	111 769 

Roof conductor holder for RIB-ROOF 465 on request.

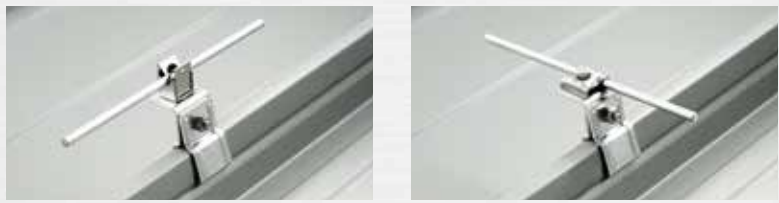

Roof conductor holder for Kalzip, with Niro-Clip (J.P. patent)



Ord. no. 111 750      Ord. no. 111 750 S

Roof conductor holder for Kalzip



Ord. no. 1309      Ord. no. 1309 S

Roof conductor holder for RIB-Roof 500, with Niro-Clip (J.P. patent)

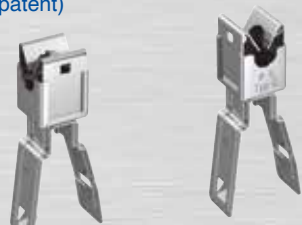

Ord. no. 111 760      Ord. no. 111 761

Roof conductor holder for RIB-Roof 500, with Niro-Clip



Ord. no. 111 764      Ord. no. 111 768

Wall and roof conductor holders

\*) **Type A (fl)** = fixed conductor leading; **Type B (ll)** = loose conductor leading



## Roof conductor holder with Niro-Clip



Ord. no. 111 144

Ord. no. 110 520



Ord. no. 111 145

Ord. no. 110 522

## PRÖ COLOR

## Roof conductor holder with Niro-Clip



Ord. no. 111 144 az



Ord. no. 111 144 ro

## Roof conductor holder



Ord. no. 111 141

Ord. no. 111 132

**Roof conductor holder** suitable for ridge tiles of all sizes  
- universally adjustable installing round conductors. **Benefit:** one type fits all!

Specification	Type A Fixed conductor leading	Height	Fit	PU	Ord. no.
<b>Bottom part</b>	<b>Niro-Clip</b>				
Stainless steel V2A	Stainless steel V2A	17 mm	ø 8 mm	100	111 144
Copper	Stainless steel V2A/coppered	17 mm	ø 8 mm	100	111 145
Stainless steel V2A	Stainless steel V2A	38 mm	ø 8 mm	50	110 520
Copper	Stainless steel V2A/coppered	38 mm	ø 8 mm	50	110 522

Specification	Type B Loose conductor leading	Height	Fit	PU	Ord. no.
<b>Bottom part</b>	<b>Niro-Clip</b>				
Stainless steel V2A	Stainless steel V2A	16 mm	ø 8 mm	100	111 136
Copper	Stainless steel V2A/coppered	16 mm	ø 8 mm	100	111 137
Stainless steel V2A	Stainless steel V2A	37 mm	ø 8 mm	50	110 521
Copper	Stainless steel V2A/coppered	37 mm	ø 8 mm	50	110 523

**PRÖ-COLOR Roof conductor holder** suitable for ridge tiles of all sizes  
- universally adjustable installing round conductors. **Benefit:** one type fits all!

Specification	Type A Fixed conductor leading	Height	Fit	PU	Ord. no.
<b>Bottom part</b>	<b>Niro-Clip</b>				
Steel, hot galvanized/coated	Stainless steel V2A	17 mm	ø 8 mm	100	111 144 az
Steel, hot galvanized/coated	Stainless steel V2A	17 mm	ø 8 mm	100	111 144 ro
Specification	Type B Loose conductor leading	Height	Fit	PU	Ord. no.
<b>Bottom part</b>	<b>Niro-Clip</b>				
Steel, hot galvanized/coated	Stainless steel V2A	16 mm	ø 8 mm	100	111 136 az
Steel, hot galvanized/coated	Stainless steel V2A	16 mm	ø 8 mm	100	111 136 ro

**Specifications:** ● ro - colour of the conductor holder: red brown  
● az - colour of the conductor holder: anthracite

**Roof conductor holder** suitable for ridge tiles of all sizes  
- universally adjustable installing round conductors. **Benefit:** one type fits all!

Specification	Fit	PU	Ord. no.
Stainless steel V2A	ø 8-10 mm	100	111 140
Copper	ø 8 mm	100	111 141
<b>Bottom part</b>	<b>Niro-Clip</b>		
Stainless steel V2A	Type A fixed conductor leading	ø 8 mm	100
Stainless steel V2A	Type B loose conductor leading	ø 8 mm	100
Copper	Type A fixed conductor leading	ø 8 mm	100
Copper	Type B loose conductor leading	ø 8 mm	100

## Roof conductor holder with springs

Universal use for the roof ridge.

**Roof conductor holder** with 2 tension springs made of stainless steel and wire hook for permanent and fast installation on the roof ridge - with lateral conductor leading. Suitable for ridge tiles of all sizes.

Specification	Type A fixed cond. leading	Height	Fit	PU	Ord. no.
<b>Bottom part</b>	<b>Niro-Clip lateral</b>				
Stainless steel V2A	Stainless steel V2A	37 mm	ø 8 mm	25	111 191
Stainless steel / coppered	Stainless steel / coppered	37 mm	ø 8 mm	25	111 196
Stainless steel V2A	Stainless steel V2A	58 mm	ø 8 mm	25	110 524

Specification	Type B loose cond. leading	Height	Fit	PU	Ord. no.
<b>Bottom part</b>	<b>Niro-Clip lateral</b>				
Stainless steel V2A	Stainless steel V2A	36 mm	ø 8 mm	25	111 175
Stainless steel / coppered	Stainless steel / coppered	36 mm	ø 8 mm	25	111 176
Stainless steel V2A	Stainless steel V2A	57 mm	ø 8 mm	25	110 525
Stainless steel / coppered	Stainless steel / coppered	57 mm	ø 8 mm	25	110 527

**Roof conductor holder** with 2 tension springs made of stainless steel and second flat hook for permanent and fast installation on the roof ridge - with lateral conductor leading. Suitable for ridge tiles of all sizes.

Specification	Type A fixed cond. leading	Height	Fit	PU	Ord. no.
<b>Bottom part</b>	<b>Niro-Clip lateral</b>				
Stainless steel V2A	Stainless steel V2A	37 mm	ø 8 mm	25	110 538
Stainless steel / coppered	Stainless steel / coppered	37 mm	ø 8 mm	25	110 542
Stainless steel V2A	Stainless steel V2A	58 mm	ø 8 mm	25	110 539

Specification	Type B loose cond. leading	Height	Fit	PU	Ord. no.
<b>Bottom part</b>	<b>Niro-Clip lateral</b>				
Stainless steel V2A	Stainless steel V2A	36 mm	ø 8 mm	25	110 540
Stainless steel / coppered	Stainless steel / coppered	36 mm	ø 8 mm	25	110 544
Stainless steel V2A	Stainless steel V2A	57 mm	ø 8 mm	25	110 541
Stainless steel / coppered	Stainless steel / coppered	57 mm	ø 8 mm	25	110 545

**Roof conductor holder** with 2 tension springs made of stainless steel and wire hook for permanent and fast installation on the roof ridge - with central conductor leading. Suitable for ridge tiles of all sizes.

Specification	Type A fixed cond. leading	Height	Fit	PU	Ord. no.
<b>Bottom part</b>	<b>Niro-Clip central</b>				
Stainless steel V2A	Stainless steel V2A	39 mm	ø 8 mm	25	111 192
Stainless steel / coppered	Stainless steel / coppered	39 mm	ø 8 mm	25	111 197
Stainless steel V2A	Stainless steel V2A	61 mm	ø 8 mm	25	110 528
Stainless steel / coppered	Stainless steel / coppered	61 mm	ø 8 mm	25	110 530

Specification	Type B loose cond. leading	Height	Fit	PU	Ord. no.
<b>Bottom part</b>	<b>Niro-Clip central</b>				
Stainless steel V2A	Stainless steel V2A	38 mm	ø 8 mm	25	111 177
Stainless steel / coppered	Stainless steel / coppered	38 mm	ø 8 mm	25	111 178
Stainless steel V2A	Stainless steel V2A	60 mm	ø 8 mm	25	110 529
Stainless steel / coppered	Stainless steel / coppered	60 mm	ø 8 mm	25	110 531

**Roof conductor holder** with 2 tension springs made of stainless steel and second flat hook for permanent and fast installation on the roof ridge - with central conductor leading. Suitable for ridge tiles of all sizes.

Specification	Type B loose cond. leading	Height	Fit	PU	Ord. no.
<b>Bottom part</b>	<b>Niro-Clip central</b>				
Stainless steel V2A	Stainless steel V2A	38 mm	ø 8 mm	25	110 546

\*) **Type A (fl)** = fixed conductor leading; **Type B (ll)** = loose conductor leading

## Roof conductor holder with Niro-Clip (with lateral conductor leading)

(J&P patent)

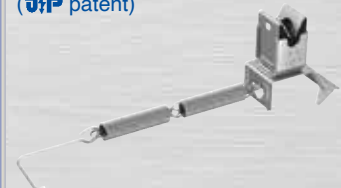

Ord. no. 111 191

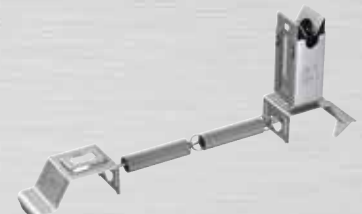

Ord. no. 110 539

## Roof conductor holder with Niro-Clip (with central conductor leading)

(J&P patent)

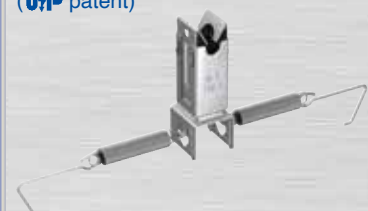

Ord. no. 110 528



Ord. no. 110 546



## Roof conductor holder for synthetic roofing membranes

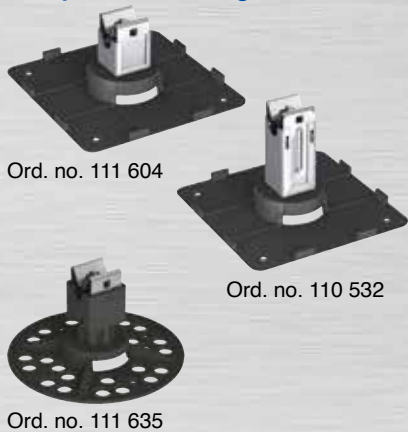

Ord. no. 111 604

Ord. no. 110 532

Ord. no. 111 635

## Roof conductor holder with Niro-Clip

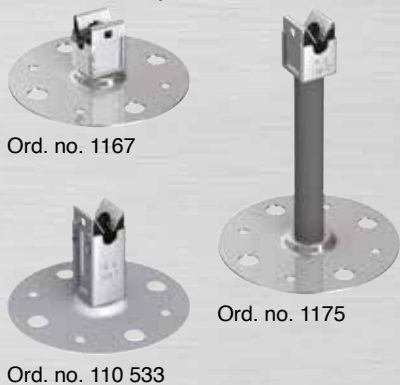

Ord. no. 1167

Ord. no. 1175

Ord. no. 110 533

## Roof conductor holder with Niro-Clip



Ord. no. 111 661

Ord. no. 111 631

**Roof conductor holder** for synthetic roofing membranes and bitumen roofs. To be fixed onto synthetic roofing membranes with weldable fastening strips; glued directly onto bitumen roofs (PA 6 = polyamide 6).

Specification		Height	Fit	PU	Ord. no.
<b>Bottom part</b>	<b>Niro-Clip *)</b>				
Plastic	Stainless steel V2A /type B	30 mm	ø 8 mm	100	111 604
Plastic	Stainless steel V2A /type B	51 mm	ø 8 mm	50	110 532
Plastic PA 6 round for bitumen roofs	Stainless steel V2A with PA 6 base grey	41 mm	ø 8 mm	100	111 635

Upon request, the base can also be equipped with other conductor holders.

Example of application:

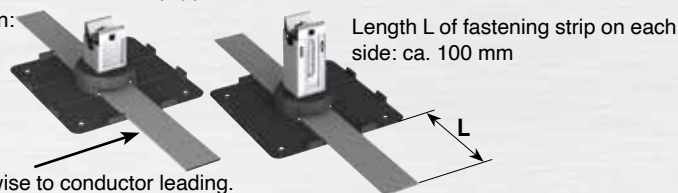

Length L of fastening strip on each side: ca. 100 mm

Fastening strip crosswise to conductor leading.

Based on the leaflet of the German roofing trade "External lightning protection on roofs and walls".

**Roof conductor holder** for bitumen sheet roofs, flat roofs and walls. (PA 6=polyamide 6) Holder with a height of 100 mm (No. 1175) for fixing the conductor onto flammable material.

Specification		Height	Fit	PU	Ord. no.
<b>Plate</b>	<b>Niro-Clip *)</b>				
Stainless steel V2A	Stainless steel V2A type A	21 mm	ø 8 mm	100	1167
Stainless steel V2A	Stainless steel V2A type A	43 mm	ø 8 mm	50	110 533
Stainless steel V2A	Stainless steel V2A type A	121 mm	ø 8 mm	50	1175

Additional types on request.

**Roof conductor holder** for metal roofs and surfaces with adhesive pad: simply remove protective film and stick on.

Specification		Height	Fit	PU	Ord. no.
<b>Support with</b>	<b>Niro-Clip *)</b>				
Adhesive pad aluminium	Stainless steel type B	21 mm	ø 8 mm	100	111 661
Adhesive pad grey	Stainless steel type B	23 mm	ø 8 mm	100	111 662
Adhesive pad aluminium	Stainless steel type B	43 mm	ø 8 mm	50	111 631
Adhesive pad grey	Stainless steel type B	45 mm	ø 8 mm	50	111 632

### Surfaces suitable for installation:

- Metal surfaces (e.g. Stainless steel, steel, aluminium)
- glass
- many plastics (e.g. hard PVC, ABS, PC, PE, PP)
- coated smooth surfaces
- ceramics
- powder coats

In case of any doubt with respect to the processed surface, please contact us!

**Note:** The smooth surface to which the support should be attached must be thoroughly cleaned e.g. with isopropyl alcohol!  
Optimal processing temperature +15 to +25°C. For additional important information please refer to the installation instructions.  
Additional types on request.

## Roof bushing

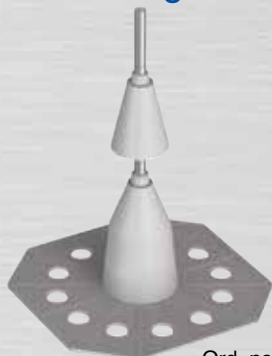

Ord. no. 111 598

**Roof bushing** for flat roofs, e.g. for internal down-conductors.

Specification	Fit	PU	Ord. no.
Nylon with PVC-sealing grommet (150 x 150 mm)	ø 8/10/16 mm	1	111 598

\*) **Type A (fl)** = fixed conductor leading; **Type B (ll)** = loose conductor leading





## PR-ÖKO 3 Roof conductor holder

### Benefits PR-ÖKO 3:

- High quality: Stainless steel clip with loose conductor leading.
- Specification: Compressed concrete block (weight: 1.2 kg) - 100% recyclable.
- No frost-sensitive cavities and recesses - totally frost-resistant.
- Weather-resistant plastic base plate made of HD-PE material.
- Application also without plastic base plate possible (e.g. on gravel roofs).



Roof conductor holder for flat roofs with stainless steel conductor holders ø 8 mm.

Specification	Fit	PU	Ord. no.
with plastic base plate	ø 8 mm	8	111 730
without plastic base plate for gravel roofs	ø 8 mm	8	111 731

## PR-ÖKO 3 (J&P patent) Roof conductor holder



Ord. no. 111 730

Ord. no. 111 731

Wall and roof  
conductor holders

## PR-ÖKO 2

### Benefits PR-ÖKO 2:

- Weather-resistant plastic component made of HD-PE material, can be installed at cold temperatures of up to -10°C.
- Specification: Compressed concrete block (weight: 1 kg) - 100% recyclable.
- No frost-sensitive cavities and recesses - totally frost-resistant.

Roof conductor holder for flat roofs with conductor holder ø 8 mm or ø 10 mm.

Specification	Fit	PU	Ord. no.
Plastic part with concrete stone	ø 8 mm	10	111 630
	ø 10 mm	10	111 633

Specification	Fit	PU	Ord. no.
Plastic part for strip fastening	ø 8 mm	50	111 660
	ø 10 mm	50	111 663

## PR-ÖKO 2 (J&P patent) Roof conductor holder



Ord. no. 111 630

Ord. no. 111 660

## PR-ÖKO 1

Roof conductor holder for flat roofs; made of black, weather-resistant plastic and recyclable filling with double conductor holder.

Specification	Fit	PU	Ord. no.
With closed plastic casing (weight: 1 kg)	ø 8 mm	10	111 600

## PR-ÖKO 1 Roof conductor holder



Ord. no. 111 600

Clamping bracket & fixing clip, to prevent flat roof holders (e.g. Ord. no. 111 630) from slipping on pitched synthetic roofing membranes.

Specification	Fit	PU	Ord. no.
<b>Clamping bracket</b> made of stainless steel V2A with M6 cylinder head screw V2A	ø 8-10 mm	100	910 097
<b>Fixing clip</b> made of stainless steel V2A	ø 8 mm	200	1163

## Clamping bracket & fixing clip



Ord. no. 910 097

Ord. no. 1163



## Spacer for eaves



Ord. no. 111 483

Spacer for eaves in cranked type on request.

## Covering and clamping cap



Ord. no. 111 485

## Roof conductor holder and mounting plate



Ord. no. 111 486



Ord. no. 111 487



Ord. no. 111 488

## Roof conductor holder for thatched roofs

### Spacer for eaves

Specification	Height (adjustable)	PU	Ord. no.
<b>Spacer for eaves</b> complete			
Stainless steel V2A	1400-1510 mm	1	111 483

Spacer for eaves in cranked type on request.

### Covering and clamping cap suitable for wooden stakes 90 x 90 mm.

Specification	PU	Ord. no.
Steel, hot galvanized	1	111 484
Stainless steel V2A	1	111 485

### Roof conductor holder and mounting plate

Specification	PU	Ord. no.
<b>Roof conductor holder</b> made of oak wood	1	111 486
<b>Mounting plate</b> 100 x 100 mm made of stainless steel V2A	1	111 487
<b>Mounting plate</b> 120 x 30 mm made of stainless steel V2A	1	111 488



# PRÖ COLOR

Colour design in lightning protection

Colour design in  
lightning protection





## PRÖ COLOR

### The benefits are obvious:

- Components made of hot galvanized steel and **PRÖ COLOR** coating.
- Decorative look and long-lasting.
- Higher quality than hot galvanized components.
- Cheaper than stainless steel V2A.
- Totally maintenance-free.

### Roof conductor holder with Niro-Clip



Ord. no. 111 144 az Ord. no. 111 144 ro

### Roof conductor holder with Niro-Clip



Ord. no. 111 019 az



Ord. no. 111 019 ro

### Roof conductor holder with Niro-Clip

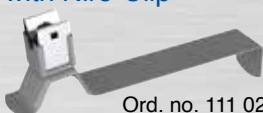

Ord. no. 111 023 az



Ord. no. 111 023 ro

### Roof conductor holder w. clamping bracket & Niro-Clip



Ord. no. 111 033 az

### Roof conductor holder w. clamping bracket & Niro-Clip



Ord. no. 111 010 az



Ord. no. 111 525 ro

Specifications: ● ro - colour of the conductor holder: red brown  
● az - colour of the conductor holder: anthracite

**Roof conductor holder** suitable for ridge tiles of all sizes  
- universally adjustable installing round conductors. **Benefits:** one type fits all!

Specification		Height	Fit	PU	Ord. no.
<b>Bottom part</b>	<b>Niro-Clip *)</b>				
Steel, hot galvanized/coated	Stainless steel V2A/ type A	17 mm	ø 8 mm	100	111 144 az
Steel, hot galvanized/coated	Stainless steel V2A/ type B	16 mm	ø 8 mm	100	111 136 az
Steel, hot galvanized/coated	Stainless steel V2A/ type A	17 mm	ø 8 mm	100	111 144 ro
Steel, hot galvanized/coated	Stainless steel V2A/ type B	16 mm	ø 8 mm	100	111 136 ro

**Roof conductor holder** for universal use.

Specification		Length	Fit	PU	Ord. no.
<b>Bottom part</b>	<b>Niro-Clip *)</b>				
Steel, hot galvanized/coated	Stainless steel V2A/ type A	210 mm	ø 8 mm	100	111 019 az
Steel, hot galvanized/coated	Stainless steel V2A/ type B	210 mm	ø 8 mm	100	111 540 az
Steel, hot galvanized/coated	Stainless steel V2A/ type A	280 mm	ø 8 mm	100	111 015 az
Steel, hot galvanized/coated	Stainless steel V2A/ type B	280 mm	ø 8 mm	100	111 541 az
Steel, hot galvanized/coated	Stainless steel V2A/ type A	210 mm	ø 8 mm	100	111 019 ro
Steel, hot galvanized/coated	Stainless steel V2A/ type B	210 mm	ø 8 mm	100	111 540 ro
Steel, hot galvanized/coated	Stainless steel V2A/ type A	280 mm	ø 8 mm	100	111 015 ro
Steel, hot galvanized/coated	Stainless steel V2A/ type B	280 mm	ø 8 mm	100	111 541 ro

**Roof conductor holder** for pantiled roofs.

Specification		Length	Fit	PU	Ord. no.
<b>Bottom part</b>	<b>Niro-Clip *)</b>				
Steel, hot galvanized/coated	Stainless steel V2A/ type A	120 mm	ø 8 mm	150	111 023 az
Steel, hot galvanized/coated	Stainless steel V2A/ type B	120 mm	ø 8 mm	150	111 530 az
Steel, hot galvanized/coated	Stainless steel V2A/ type A	120 mm	ø 8 mm	150	111 023 ro
Steel, hot galvanized/coated	Stainless steel V2A/ type B	120 mm	ø 8 mm	150	111 530 ro

**Roof conductor holder** with clamping bracket  
(clamping range max 5 mm) for slate roofs; especially well suited for later installation!

Specification		Length	Fit	PU	Ord. no.
<b>Bottom part</b>	<b>Niro-Clip *)</b>				
Steel, hot galvanized/ with teeth	Stainless steel/ type A	180 mm	ø 8 mm	200	111 033 az
Steel, hot galvanized/ with teeth	Stainless steel/ type B	180 mm	ø 8 mm	200	111 511 az

**Roof conductor holder** with clamping bracket  
for bitumen shingles and slate roofs or for tiles with large clamping range.

Specification		Clamping range	Fit	PU	Ord. no.
<b>Bottom part</b>	<b>Niro-Clip *)</b>				
Steel, hot galvanized/coated	Stainless st. V2A/ type A	up to 5 mm	ø 8 mm	100	111 010 az
Steel, hot galvanized/coated	Stainless st. V2A/ type B	up to 5 mm	ø 8 mm	100	111 011 az
Steel, hot galvanized/coated	Stainless st. V2A/ type A	up to 18 mm	ø 8 mm	100	111 525 ro
Steel, hot galvanized/coated	Stainless st. V2A/ type A	up to 18 mm	ø 8 mm	100	111 525 az
Steel, hot galvanized/coated	Stainless st. V2A/ type B	up to 18 mm	ø 8 mm	100	111 527 ro
Steel, hot galvanized/coated	Stainless st. V2A/ type B	up to 18 mm	ø 8 mm	100	111 527 az

\*) **Type A (fl)** = fixed conductor leading; **Type B (ll)** = loose conductor leading



## COLOUR DESIGN in lightning protection

### **Innovation in colour!**

This wish is fulfilled by our COLOUR DESIGN in lightning protection, whose powder-coated components are coloured to match the roof, gutters and rainwater downpipes.

The appearance of an on-roof lightning protection system can be improved by making it unobtrusive to blend in.

Components made of stainless steel, aluminium, hot galvanized steel and also aluminium wires are powder-coated using the sintering technique.

A selection of colours (Additional RAL-colours available!)



Colour design in lightning protection

The illustrated colour examples may differ from the RAL-colour.

#### Product description

#### Components:

All lightning protection components are pre-treated and powder-coated in the RAL-colour of your choice.

#### Powder coating:

The coating powder consists basically of polyester resins, as well as the appropriate weather-, light- and heat-resistant pigments.

The electrostatic charge makes the powder adhere to the component, the ensuing burn-in process binds the powder to the metal permanently. The thickness of the coating is about 60 to 90 µm. To ensure optimal conductivity, the clamping area (e.g. inner surface of the Multi-clamp) remains uncoated.

#### Wire:

Aluminium wire soft, ø 8 mm (Ord. no. 100 019 S) per ring à 10 kg, powder coated.

#### Important! The following installation instructions must be adhered to:

**When installing the wire, the coating must be removed in the area of the clamping connection without changing the cross section to guarantee a faultless conductive and lightning-current proof connection.**

The coating in the clamping area of the aluminium wire is scraped off with a “skinning tool”.

Prices for “colour design in lightning protection” on request.



## Test laboratory with 10/350 $\mu$ s impulse current generator

In our test laboratory, all lightning protection components and surge protective devices are tested according to the latest national and international standards.



## Equipment for environmental testing



Colour design in lightning protection



# Connection clamps, terminal clamps, bridgings, pipe clamps



Connection and  
terminal clamps



## Multi-Quattro - terminal and connecting clamp

The J. Pröpster **Multi-Quattro Clamp** does not only cover the well-known advantages of the Multi Clamp system, but does also offer an added value through its further numerous application possibilities which we would like to pass on to our customers.

### Benefits:

- **Safe connection** for up to **4 incoming wires**  $\varnothing$  8 or  $\varnothing$  10 mm
- Only one clamp for all wire connections.
- Shortened and simplified installation – only one M10 screw.

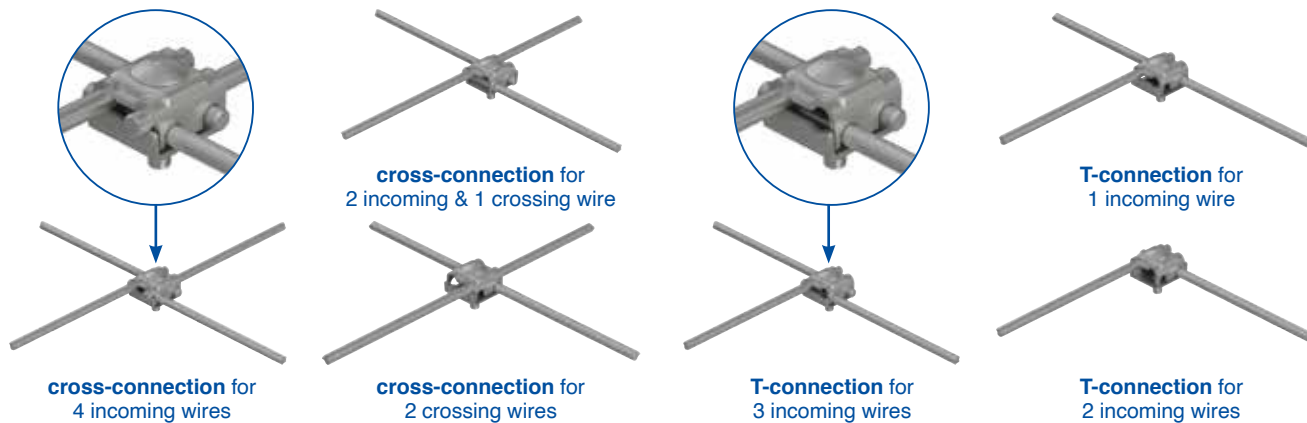

### Multi-Quattro (J.P. patent)



Ord. no. 111 314

### Multi-Quattro terminal and connecting clamp

for the connection of 2 - 4 wires  $\varnothing$  8 mm

Specification	Fit	PU	Ord. no.
Steel, hot galvanized	$\varnothing$ 8 mm	100	111 314
Aluminium	$\varnothing$ 8 mm	100	111 315
Stainless steel V2A	$\varnothing$ 8 mm	100	111 317

### Multi-Quattro terminal and connecting clamp

for connection of 2 - 4 wires  $\varnothing$  10 mm

Specification	Fit	PU	Ord. no.
NEW! Steel, hot galvanized	$\varnothing$ 10 mm	100	111 308
NEW! Stainless steel V2A	$\varnothing$ 10 mm	100	111 309
NEW! Stainless steel V4A	$\varnothing$ 10 mm	100	111 310

### Multi-Plus terminal clamp (J.P. patent)



Ord. no. 111 270

### Connecting- and terminal clamp

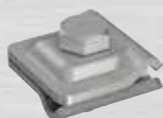

Ord. no. 111 313



Ord. no. 111 319

## System Multi-clamp

**Multi-Plus** metal sheet terminal and connection clamp. Same connection configurations as the original Multi-clamp with guaranteed 10 cm<sup>2</sup> contact surface, clamping range up to 8 mm.

Specification	Carriage bolt with nut	Fit	PU	Ord. no.
Steel, hot galvanized	Steel, hot galvanized	$\varnothing$ 8-10 mm	50	111 270
Steel, hot galvanized	Stainless steel V2A	$\varnothing$ 8-10 mm	50	111 270 S
Aluminium 4 mm	Steel, hot galvanized	$\varnothing$ 8 mm	50	111 271
Aluminium 4 mm	Stainless steel V2A	$\varnothing$ 8 mm	50	111 271 S
Copper	Coppered	$\varnothing$ 8 mm	50	111 272
Stainless steel V2A	Stainless steel V2A	$\varnothing$ 8-10 mm	50	111 273
Bimetal aluminium/copper	Stainless steel V2A	$\varnothing$ 8 mm	50	111 274

All specifications also available with  $\varnothing$  4-6 mm clamping range

### Connecting and terminal clamp

completely made of stainless steel V4A, for wire mesh mats for potential control.

Specification	Fit	PU	Ord. no.
Connection clamp: Multi-Mini	$\varnothing$ 4-6 / $\varnothing$ 4-6 mm	100	111 313
Terminal Clamp: Multi-Mini	$\varnothing$ 10 / $\varnothing$ 4-6 mm	50	111 319



## Original Multi-clamp

The **original Multi-clamp** was invented by J. Pröpster in 1981 and since then has been established a million times worldwide. It is the most varied lightning protection component and the centerpiece of the multifunctional system of J. Pröpster.

The universal use of the Multi-Clamp as T-, cross, parallel, thrust and connection clamp is unmatched.

- Benefits:**
- Only one clamp for all wire connections.
  - Maximum contact due to consistent clamping.
  - Extremely shortened installation time - only one screw M10.
  - Optimal handling at planning, acquisition and storage.

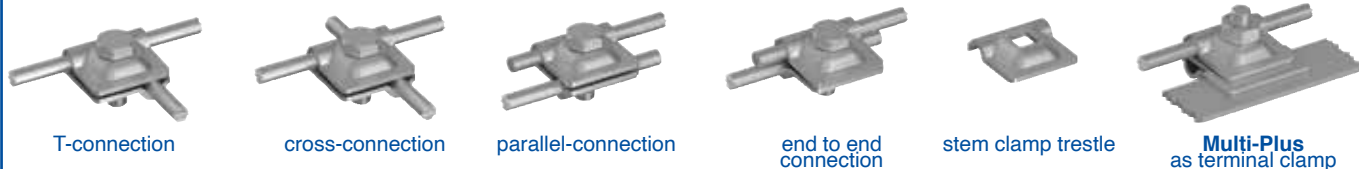

**Multi-clamp**, for the universal use as T-, cross-, parallel- and end to end-connection.

Specification	Carriage bolt with nut	Fit	PU	Ord. no.
Steel, hot galvanized	Steel, hot galvanized	ø 8-10 mm	100	1270
Aluminium 4 mm	Steel, hot galvanized	ø 8 mm	100	1271
Steel, hot galvanized 4 mm	Steel, hot galvanized	ø 8-10 mm	100	1277
Steel, hot galvanized for reinforcements	Steel, hot galvanized	ø 4-6 mm	100	111 279
Steel, bare	Steel, hot galvanized	ø 8-10 mm	100	911 224
Copper	Stainless steel V2A	ø 8 mm	100	910 101
Stainless steel V2A	Stainless steel V2A	ø 8-10 mm	100	910 107
Specification	Hexagonal screw	Fit	PU	Ord. no.
Copper	Coppered	ø 8 mm	100	1272
Stainless steel V2A	Stainless steel V2A	ø 8-10 mm	100	1273
Bimetal aluminium/copper	Stainless steel V2A	ø 8 mm	100	1274
Steel, hot galvanized	Stainless steel V2A	ø 8-10 mm	100	1275
Aluminium 4 mm	Stainless steel V2A	ø 8 mm	100	1276

**Multi-clamp ø 10 mm**, heavy-duty type for the universal use as T-, cross-, parallel- and end to end-connection.

Specification	Carriage bolt with nut	Fit	PU	Ord. no.
Steel, hot galvanized	Steel, hot galvanized	ø 10 mm	75	1278
Stainless steel V2A	Stainless steel V2A	ø 10 mm	75	1279
Stainless steel V4A	Stainless steel V2A	ø 10 mm	75	1279 S
Copper	Coppered	ø 10 mm	75	111 280

**Multi-clamp ø 8-10 mm / ø 16 mm**  
**Benefits:** The reliable Multi-clamp system for ø 16 mm rod connections.

Specification	Carriage bolt with nut	Fit	PU	Ord. no.
Steel, hot galvanized	Steel, hot galvanized	ø 8-10 / ø 16 mm	50	111 430
Copper	Coppered	ø 8 / ø 16 mm	50	111 432
Stainless steel V2A	Stainless steel V2A	ø 8-10 / ø 16 mm	50	111 433

## Original Multi-clamp by J. Pröpster



Ord. no. 1270

Ord. no. 1272

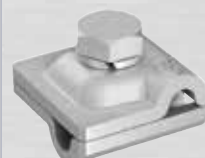

Ord. no. 1276

## Multi-clamp ø 10 mm



Ord. no. 1278

## Multi-clamp ø 8-10 mm / ø 16 mm



Ord. no. 111 430

Connection and terminal clamps



## J.Pröpster CC-Clamping system

for connections  $\varnothing$  8-10 /  $\varnothing$  16 mm

to clamps, pipe clamps or steel constructions.

- **Type A:** Connection of air termination rods or earth lead-in rods  $\varnothing$  16 mm to clamps, pipe clamps or metal constructions.
- **Type B:** Connection of rods  $\varnothing$  16 mm and conductors  $\varnothing$  8-10 mm to clamps, pipe clamps or metal constructions.
- **Type C:** Connection and disconnection clamp  $\varnothing$  8-10 /  $\varnothing$  16 mm - also suitable for cable connections.

### Benefits:

- Clamping system for round connectors  $\varnothing$  8-10 /  $\varnothing$  16 mm.
- Variable fixing lengths by easy swap of the hexagonal bolt M10.

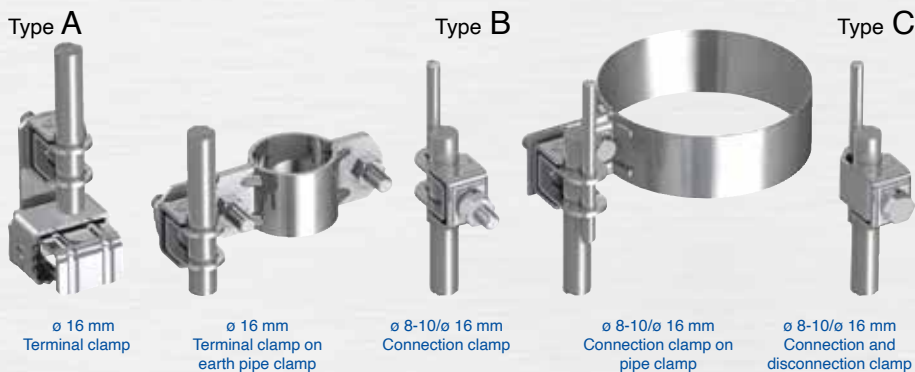

## J.Pröpster CC-Clamp

### Type A



Ord. no. 1460

### Type B



Ord. no. 1461

## U-Connector



Ord. no. 111 410

## J.Pröpster CC-Disconnecting Clamp

### Type C



Ord. no. 1458

## J.Pröpster CC-Clamp

for the connection of round connectors  $\varnothing$  8-10 mm and air termination rods  $\varnothing$  16 mm.

Specification	Type	Fit	PU	Ord. no.
Steel, hot galvanized	<b>A</b>	$\varnothing$ 16 mm	50	1455
<b>Stainless steel V2A</b>	<b>A</b>	$\varnothing$ 16 mm	50	1460
Steel, hot galvanized	<b>B</b>	$\varnothing$ 8-10 / $\varnothing$ 16 mm	50	1456
<b>Stainless steel V2A</b>	<b>B</b>	$\varnothing$ 8-10 / $\varnothing$ 16 mm	50	1461

**U-Connector** with hexagonal screw M10 V2A for round connector  $\varnothing$  8-10 mm and air termination rods  $\varnothing$  16 mm.

Specification	Fit	PU	Ord. no.
Steel, hot galvanized	$\varnothing$ 8-10 / $\varnothing$ 16 mm	100	111 410
<b>Copper</b>	$\varnothing$ 8-10 / $\varnothing$ 16 mm	100	111 411
<b>Stainless steel V2A</b>	$\varnothing$ 8-10 / $\varnothing$ 16 mm	100	111 412

## J.Pröpster CC-Clamping system

for the connection of round conductors  $\varnothing$  8-10 mm and air termination rods  $\varnothing$  16 mm.

Specification	Type	Fit	PU	Ord. no.
Steel, hot galvanized	<b>C</b>	$\varnothing$ 8-10/ $\varnothing$ 16 mm	50	1457
<b>Stainless steel V2A</b>	<b>C</b>	$\varnothing$ 8-10/ $\varnothing$ 16 mm	50	1458
<b>Copper</b>	<b>C</b>	$\varnothing$ 8-10/ $\varnothing$ 16 mm	50	1459

Also suitable for cable connection



**Multi-Quattro** for the connection of up to 4 incoming wires  
 ø 8 mm on clamps

**Multi-Quattro clamping jaw**  
 for the connection of 2 - 4 wires ø 8 mm

Specification	Fit	PU	Ord. no.
Steel, hot galvanized	ø 8 mm	100	111 304
Aluminium	ø 8 mm	100	111 305
Copper	ø 8 mm	100	111 306
Stainless steel V2A	ø 8 mm	100	111 307



## Connectors

**Clamping jaw**, suitable for one or two round conductors with □ 11 mm square hole,  
 light-weight type with ø 8.5 mm.

Specification	Bore hole	Fit	PU	Ord. no.	
Steel, hot galvanized	□ 11 mm	ø 8-10 mm	100	1284	
Aluminium		ø 8 mm	100	1285	
Copper		ø 8 mm	100	1286	
Stainless steel V2A		ø 8-10 mm	100	1287	
Steel, hot galvanized	light-weight type	ø 8.5 mm	ø 6-8 mm	100	111 284
Aluminium	light-weight type		ø 6-8 mm	100	111 285
Copper	light-weight type		ø 6-8 mm	100	111 286
Stainless steel V2A	light-weight type		ø 6-8 mm	100	111 287

## Dual-cross terminal and connection clamps

Specification	Fit	PU	Ord. no.
Suitable for one or two round conductors with M10 screw and nut, with base plate.			
Steel, hot galvanized	ø 8-10 mm	100	1280
Aluminium	ø 8 mm	100	1281
Copper	ø 8 mm	100	1282
Stainless steel V2A	ø 8-10 mm	100	1283

## KS-Connector

Clamping screw with hexagonal nut M10 suitable for round conductor ø 6-10 mm.

Specification	Fit	PU	Ord. no.
Steel, hot galvanized / aluminium clamping ring	ø 6-10 mm	100	1360
Steel, hot galvanized with square clamping bracket	ø 8-10 mm	100	1359
Stainless steel V2A coppered	ø 6-10 mm	100	1361
Stainless steel V2A	ø 6-10 mm	100	1362
NEW! Stainless steel V4A	ø 6-10 mm	100	1464

## KS-Connector, double

Clamping screw with hexagonal nut M10 suitable for round conductor ø 6-10 mm.

Specification	Fit	PU	Ord. no.
Steel, hot galvanized / aluminium clamping ring	ø 6-10 mm	50	111 370
Stainless steel V2A coppered	ø 6-10 mm	50	111 371
Stainless steel V2A	ø 6-10 mm	50	2000

## Multi-Quattro (J.P.R. patent)



Best.-Nr. 111 304

## Clamping jaw



Ord. no. 1284

Ord. no. 111 284

Connection and terminal clamps

## Dual-cross terminal and connection clamp



Ord. no. 1280

## KS-Connector



Ord. no. 1362

Ord. no. 1464

## KS-Connector, double



Ord. no. 2000



## ES-connector



Ord. no. 2105

## Connection Clamp



Ord. no. 2100

## Terminal angle



Ord. no. 1363

Ord. no. 1381

## Terminal angle



Ord. no. 1383

Ord. no. 1384

## Terminal angle with terminal clamp

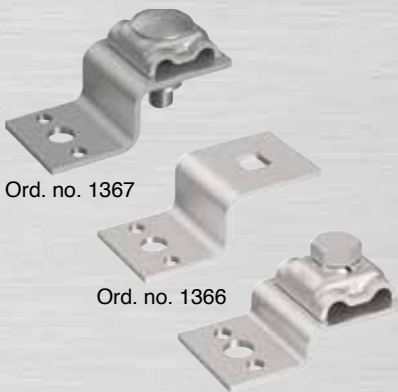

Ord. no. 1367

Ord. no. 1366

Ord. no. 910 183

## ES-connector with screw and nut M10 for the connection of round conductors.

Specification	Fit	PU	Ord. no.
Zinc die-cast with hot galvanized steel-screw	ø 8 mm	100	2105
Zinc die-cast with V2A-screw and nut	ø 8 mm	100	2106

## Connection clamp for the connection of two round conductors.

Specification	Fit	PU	Ord. no.
Zinc die-cast	ø 8-10 mm	100	2100
Aluminium	ø 8 mm	100	2101
Aluminium continuous casting	ø 8-10 mm	100	2104
Copper	ø 8 mm	100	2102
Stainless steel V2A	ø 8 mm	100	2103
Stainless steel V2A	ø 10 mm	100	2107
Aluminium, mounted with four M8 hexagonal screws stainless steel V2A	ø 16 mm	25	2108

## Terminal angle for the connection to metal constructions.

With or without clamping jaw.

Specification	Fit	PU	Ord. no.
Aluminium with connector	ø 8 mm	50	1363
Aluminium without connector	---	100	1381
Copper with connector	ø 8 mm	50	1364
Copper without connector	---	100	1382
Stainless steel V2A with connector	ø 8-10 mm	50	1390 S
Stainless steel V2A without connector	---	100	1390

## Terminal angle to screw or weld on metal constructions.

Bore hole: 2x ø 11 mm; 1x □ 11 mm

Specification	Fit	PU	Ord. no.
Steel, hot galvanized with KS-Connector	ø 6-10 mm	50	1383
Steel, hot galvanized without KS-Connector	---	100	1384
Stainless steel V2A without KS-Connector	---	100	1385

## Terminal angle for the connection of metal structural cladding.

With or without clamping jaw.

Specification	Fit	PU	Ord. no.
Aluminium with connector, screw and nut	ø 8 mm	50	1367
Copper with connector, screw and nut	ø 8 mm	50	1368
Aluminium without connector	---	50	1366

Also available with KS-Connector

Specification	Fit	PU	Ord. no.
Aluminium with connector, hexagonal screw and thread	ø 8 mm	50	910 183

## Gutter clamps

### Benefits gutter clamp - ideal:

- Perfect, large clamping area below the bead.
- Slim conductor holder design - only 32 mm wide, safety tested.
- Clamping screws always made of stainless steel V2A.
- Installation: Clamp and down conductor wire can be mounted separately.

### Gutter clamp - ideal,

for secure connection on gutters with up to  $\varnothing$  20 mm bead thicknesses.

Specification	Fit	PU	Ord. no.
Steel, hot galvanized/zinc-plated	$\varnothing$ 6-8 mm	25	111 670
Aluminium, Wire clamp stainless steel V2A	$\varnothing$ 6-8 mm	25	111 671
Copper	$\varnothing$ 6-8 mm	25	111 672
Stainless steel V2A	$\varnothing$ 6-8 mm	25	111 673
Bimetal Wire clamp - stainless steel V2A	$\varnothing$ 6-8 mm	25	111 674
Bimetal Bead clamp - copper	$\varnothing$ 6-8 mm	25	111 674

**Gutter terminal clamp** to fix air termination conductors and down conductors to the gutter. Fits for bead thicknesses  $\varnothing$  15 - 20 mm.

Specification	Fit	PU	Ord. no.
Steel, hot galvanized	$\varnothing$ 8-10 mm	25	1306
Aluminium	$\varnothing$ 8 mm	25	1305
Copper	$\varnothing$ 8 mm	25	1307
Stainless steel V2A	$\varnothing$ 8-10 mm	25	1308
Aluminium with Stainless steel V2A - screw	$\varnothing$ 8 mm	25	1305 S
Bimetal Wire clamp - aluminium	$\varnothing$ 8 mm	25	1307 Z
Bimetal Bead clamp - copper	$\varnothing$ 8 mm	25	1307 Z

Additional versions on request

**Gutter clamp - slim** to fix air termination conductors and down conductors to the gutter. Fits for bead thicknesses with up to  $\varnothing$  20 mm.

Specification	Fit	PU	Ord. no.
Steel, hot galvanized	$\varnothing$ 6-8 mm	50	111 675
Aluminium, Wire clamp stainless steel V2A	$\varnothing$ 6-8 mm	50	111 676
Copper	$\varnothing$ 6-8 mm	50	111 677
Stainless steel V2A	$\varnothing$ 6-8 mm	50	111 678
Bimetal Wire clamp - stainless steel V2A	$\varnothing$ 6-8 mm	50	111 679
Bimetal Bead clamp - copper	$\varnothing$ 6-8 mm	50	111 679

**Gutter clamp** fits for bead thicknesses  $\varnothing$  10 - 20 mm.

Specification	Fit	PU	Ord. no.
Steel, hot galvanized	$\varnothing$ 8-10 mm	50	1302
Aluminium	$\varnothing$ 8 mm	50	1301
Copper	$\varnothing$ 8-10 mm	50	1300
Stainless steel V2A	$\varnothing$ 8-10 mm	50	2001
Bimetal Wire clamp - aluminium	$\varnothing$ 8 mm	50	1300 Z
Bimetal Bead clamp - copper	$\varnothing$ 8 mm	50	1300 Z

Specification with hexagonal screw available

**Conductor collar** for down conductors to protect frontages and walls from running rainwater

Specification	Fit	PU	Ord. no.
Plastic grey for conductors	$\varnothing$ 8 mm	100	1042 S
Plastic copper - coloured for conductors	$\varnothing$ 8 mm	100	1046 S

More information about the bimetal system on pages 104 and 105.

### Gutter clamp - ideal



Ord. no. 111 670

### Gutter terminal clamp (J&P patent)



Ord. no. 1306

### Gutter clamp - slim



Ord. no. 111 675

### Gutter clamp



Ord. no. 1302

### Conductor collar



Ord. no. 1042 S



## Disconnecting clamp



Ord. no. 1330



Ord. no. 1332



Ord. no. 111 405

## Disconnecting clamp



Ord. no. 1333

## Disconnecting clamp



Ord. no. 111 375

## J.Pröpster CC-Disconnecting Clamp

Type **C**



Ord. no. 1458

## Disconnecting clamp

**Disconnecting clamp** according to EN 62561-1 fits for round conductors  $\varnothing$  8-10 /  $\varnothing$  16 mm or  $\varnothing$  8 /  $\varnothing$  10 mm, mounted with two hexagonal screws M8 stainless steel V2A.

Specification	Fit	PU	Ord. no.
Aluminium	$\varnothing$ 8-10 / $\varnothing$ 16 mm	50	1330

Specification	Fit	PU	Ord. no.
Aluminium	$\varnothing$ 8-10 / $\varnothing$ 10 mm	50	1332

Specification	Fit	PU	Ord. no.
Zinc die-cast, closed type	$\varnothing$ 8-10 / $\varnothing$ 16 mm	50	111 405
Copper-alloy	$\varnothing$ 8-10 / $\varnothing$ 16 mm	50	1331

See also Vario-Disconnecting clamp on pages 98 and 99.

**Disconnecting clamp** fits for round connectors  $\varnothing$  8 mm to  $\varnothing$  10 mm, with one screw M10 and nut.

Specification	Fit	PU	Ord. no.
Stainless steel V2A	$\varnothing$ 8 / $\varnothing$ 10 mm	50	1333

**Disconnecting clamp** according to EN 62561-1, with two KS-Connectors steel, hot galvanized M10 and two hexagonal screws M8 stainless steel V2A.

Specification	Fit	PU	Ord. no.
Steel, hot galvanized / aluminium	$\varnothing$ 6-10 / $\varnothing$ 6-10 mm	50	111 375

Clamp in stainless steel V2A on request.

## J.Pröpster CC-Clamping system

for the connection of round conductors  $\varnothing$  8-10 mm and air termination rods  $\varnothing$  16 mm.

Specification	Type	Fit	PU	Ord. no.
Steel, hot galvanized	C	$\varnothing$ 8-10/ $\varnothing$ 16 mm	50	1457
Stainless steel V2A	C	$\varnothing$ 8-10/ $\varnothing$ 16 mm	50	1458
Copper	C	$\varnothing$ 8-10/ $\varnothing$ 16 mm	50	1459

Also suitable for cable connection. Additional CC-Clamps on page 90.



## Disconnecting clamp with connecting bracket

### Benefits:

- Improved flush fit with open-end wrench by patented cylindrical design of the Vario-clamp upper part.
- Universal utilization, e.g. installation with a terminal clamp on a T-beam or direct installation on a fixed earthing terminal.
- Economical solution: Connecting bracket and disconnection within one component.

**Disconnecting clamp with terminal angle,**  
for test joints  $\varnothing$  8-10 mm or flat 30 mm; mounted with 2 hexagonal screws M8.

Specification	Bore	Conductor height	Fit	PU	Ord. no.
Steel, hot galvanized	$\varnothing$ 12.5 mm	14 mm	$\varnothing$ 8-10 mm	50	111 700
Stainless steel V2A	$\varnothing$ 12.5 mm	14 mm	$\varnothing$ 8-10 mm	50	111 701
Stainless steel V4A	$\varnothing$ 12.5 mm	14 mm	$\varnothing$ 8-10 mm	50	111 704
Steel, hot galvanized	$\varnothing$ 12.5 mm	14 mm	fl. 30 mm	50	111 702
Stainless steel V2A	$\varnothing$ 12.5 mm	14 mm	fl. 30 mm	50	111 703
Stainless steel V4A	$\varnothing$ 12.5 mm	14 mm	fl. 30 mm	50	111 705

Connection bracket with rivet design upon request.

**Disconnecting clamp with terminal angle -high version-,**  
for test joints  $\varnothing$  8-10 mm or flat 30 mm; mounted with 2 hexagonal screws M8.  
Suitable for measurements with clamp-on ground resistance tester (Ord. no. 2081 or 2084).

Specification	Bore	Conductor height	Fit	PU	Ord. no.
Steel, hot galvanized	$\varnothing$ 12.5 mm	30 mm	$\varnothing$ 8-10 mm	50	111 740
Stainless steel V2A	$\varnothing$ 12.5 mm	30 mm	$\varnothing$ 8-10 mm	50	111 741
Stainless steel V4A	$\varnothing$ 12.5 mm	30 mm	$\varnothing$ 8-10 mm	50	111 744
Steel, hot galvanized	$\varnothing$ 12.5 mm	30 mm	fl. 30 mm	50	111 742
Stainless steel V2A	$\varnothing$ 12.5 mm	30 mm	fl. 30 mm	50	111 743
Stainless steel V4A	$\varnothing$ 12.5 mm	30 mm	fl. 30 mm	50	111 745

Connection bracket with rivet design on request.

Application examples



with terminal clamp, heavy-duty type



with fixed earthing terminal

## Test joint with insulating piece

**Test joint** for quick and easy opening of the connection between down conductor and earth lead-in rod with fixed conductor ends

Specification	Fit	PU	Ord. no.
<b>NEW!</b> Stainless steel V2A / plastic	$\varnothing$ 8-10 / fl. 30mm	10	111 377

## Disconnecting clamp with terminal angle



Ord. no. 111 700

Ord. no. 111 702



Ord. no. 111 740

Ord. no. 111 742

Connection and terminal clamps

## Test joint with insulating piece



Ord. no. 111 377



## System Vario-clamp with screws M10, width of clamp 40 mm

The **original system Vario-clamp** is a practical solution for connecting differently shaped conductors. All parts are manufactured using punching technology and are interchangeable.



ø 8-10/8-10 mm



ø 8-10/16 mm



ø 8-10/30x3.5 mm  
ø 8-10/40x4 mm



30x3.5/30x3.5 mm  
40x4/40x4 mm

## Vario-Disconnecting clamp



Ord. no. 1340



Ord. no. 111 339

**Vario-Disconnecting clamp**, for test joints round/flat, flat/flat and round/round; mounted with two hexagonal screws M10 stainless steel V2A.

Specification		Fit	PU	Ord. no.
Steel, hot galvanized	two-part	round/flat	ø 8-10/30 mm	50 1340
Steel, hot galvanized	two-part	round/flat	ø 8-10/40 mm	50 1346
Steel, hot galvanized	two-part	flat/flat	30/30 mm	50 1343
Steel, hot galvanized	two-part	flat/flat	40/40 mm	50 2044
Steel, hot galvanized	two-part	round/round	ø 8-10/ø 8-10 mm	50 1339
<b>Stainless steel V2A</b>	two-part	round/flat	ø 8-10/30 mm	50 <b>2012</b>
<b>Stainless steel V2A</b>	two-part	flat/flat	30/30 mm	50 <b>2014</b>
<b>Stainless steel V2A</b>	two-part	round/round	ø 8-10/ø 8-10 mm	50 <b>2016</b>
<b>Copper</b>	two-part	round/round	ø 8-10/ø 8-10 mm	50 <b>1337</b>
Steel, hot galvanized	three-part	round/round	ø 8-10/ø 8-10 mm	50 111 339
<b>Copper</b>	three-part	round/round	ø 8-10/ø 8-10 mm	50 <b>111 337</b>
<b>Copper-Steel, hot gal.</b>	three-part	round/flat	ø 8-10/30 mm	50 <b>1342 Z</b>
<b>Stainless steel V2A</b>	three-part	round/round	ø 8-10/ø 8-10 mm	50 <b>910 579</b>

## Vario-Disconnecting clamp



Ord. no. 1341



Ord. no. 1345

**Vario-Disconnecting clamp**, for test joints round/round; mounted with two hexagonal screws M10 stainless steel V2A.

Specification		Fit	PU	Ord. no.
Steel, hot galvanized	two-part	round/round	ø 8-10/ø 16 mm	50 1341
<b>Aluminium</b>	two-part	round/round	ø 8-10/ø 16 mm	50 <b>1344</b>
<b>Copper</b>	two-part	round/round	ø 8-10/ø 16 mm	50 <b>111 341</b>
<b>Stainless steel V2A</b>	two-part	round/round	ø 8-10/ø 16 mm	50 <b>2006</b>
<b>Copper-Steel, hot gal.</b>	three-part	round/round	ø 8-10/ø 16 mm	50 <b>1348 Z</b>
Steel, hot galvanized	three-part	round/round	ø 8-10/ø 16 mm	50 1345
<b>Aluminium</b>	three-part	round/round	ø 8-10/ø 16 mm	50 <b>111 344</b>
<b>Copper</b>	three-part	round/round	ø 8-10/ø 16 mm	50 <b>111 345</b>
<b>Stainless steel V2A</b>	three-part	round/round	ø 8-10/ø 16 mm	50 <b>2007</b>
Steel, hot gal. - <b>Copper</b>	three-part	round/round	ø 8-10/fl.30/ø 16 mm	50 <b>1349 Z</b>
<b>Copper-Steel, hot gal.</b>	three-part	round/round	ø 8-10/ø 8-10 mm	50 <b>1343 Z</b>

## Vario-Connecting clamp, two-part



Ord. no. 1342

**Vario-Connecting clamp**, for flat/round and flat/flat connections; mounted with two screws M10 steel, hot galvanized.

Specification		Fit	PU	Ord. no.
Steel, hot galvanized	two-part	round/flat	ø 8-10/30 mm	50 1342
Steel, hot galvanized	two-part	round/flat	ø 8-10/40 mm	50 2043
Steel, hot galvanized	two-part	flat/flat	30/30 mm	50 1347

More information about the bimetal Vario-clamp can be found on page 102.



## System Vario-clamp M8-Plus

with screws M8, width of clamp 30 mm

The **original system Vario-clamp M8-Plus**, is a reasonably priced, practical solution for connecting differently shaped conductors. All parts are manufactured using punching technology and are interchangeable.

**Benefits:** The patented cylindrical attachment on the upper part significantly improves installation.



ø 8-10/8-10 mm



ø 8-10/16 mm



ø 8-10/30x3.5 mm



30x3.5/30x3.5 mm



System Bimetal  
ø 8-10/30x3.5 mm

## Vario-Disconnecting clamp M8-Plus,

for test joints round/flat, flat/flat und round/round; mounted with two hexagonal screws M8 V2A.

Specification			Fit	PU	Ord. no.
Steel, hot galvanized	two-part	round/flat	ø 8-10 / 30 mm	50	111 716
Steel, hot galvanized	two-part	flach/flach	30 / 30 mm	50	111 718
Steel, hot galvanized	two-part	round/round	ø 8-10 / ø 8-10 mm	50	111 710
<b>Stainless steel V2A</b>	two-part	round/flach	ø 8-10 / 30 mm	50	<b>111 717</b>
<b>Stainless steel V2A</b>	two-part	flach/flach	30 / 30 mm	50	<b>111 719</b>
<b>Stainless steel V2A</b>	two-part	round/round	ø 8-10 / ø 8-10 mm	50	<b>111 711</b>
<b>Copper</b>	two-part	round/round	ø 8-10 / ø 8-10 mm	50	<b>111 712</b>
Steel, hot galvanized	three-part	round/round	ø 8-10 / ø 8-10 mm	50	111 713
<b>Copper</b>	three-part	round/round	ø 8-10 / ø 8-10 mm	50	<b>111 715</b>
<b>Copper-steel, hot gal.</b>	three-part	round/flach	ø 8-10 / 30 mm	50	<b>111 727</b>
<b>Stainless steel V2A</b>	three-part	round/round	ø 8-10 / ø 8-10 mm	50	<b>111 714</b>

Sure torque transmission thanks to a better form fit. (open-ended spanner rests securely on the screw head).

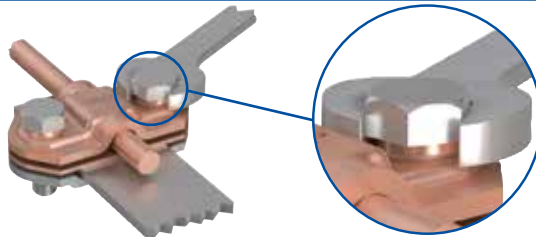

Screw head sits higher due to collar

## Vario-Disconnecting clamp M8-Plus (J&P patent)



Ord. no. 111 717



Ord. no. 111 727



Ord. no. 111 714

## Vario-Disconnecting clamp M8-Plus,

for test joints round/round; mounted with two hexagonal screws M8 stainless steel V2A.

Specification			Fit	PU	Ord. no.
Steel, hot galvanized	two-part	round/round	ø 8-10 / ø 16 mm	50	111 720
<b>Copper</b>	two-part	round/round	ø 8-10 / ø 16 mm	50	<b>111 722</b>
<b>Stainless steel V2A</b>	two-part	round/round	ø 8-10 / ø 16 mm	50	<b>111 721</b>
Steel, hot galvanized	three-part	round/round	ø 8-10 / ø 16 mm	50	111 723
<b>Copper</b>	three-part	round/round	ø 8-10 / ø 16 mm	50	<b>111 725</b>
<b>Stainless steel V2A</b>	three-part	round/round	ø 8-10 / ø 16 mm	50	<b>111 724</b>
<b>Copper-Steel, hot gal.</b>	three-part	round/round	ø 8-10 / ø 16 mm	50	<b>111 728</b>
Steel, hot gal.- <b>Copper</b>	three-part	round/round	ø 8-10/fl.30/ø 16 mm	50	<b>111 729</b>
<b>Copper-Steel, hot gal.</b>	three-part	round/round	ø 8-10 / ø 8-10 mm	50	<b>111 726</b>

Test plates used for Vario-Disconnecting clamp and Vario-Disconnecting clamp M8-Plus on page 106.



## Vario-Disconnecting clamp M8-Plus (J&P patent)



Ord. no. 111 721



Ord. no. 111 724



Ord. no. 111 700

Disconnection clamp with terminal angle (Ord. no. 111 700) on page 95.



## Multi-Plus terminal clamp (J&P patent)



Ord. no. 111 270

## Saddle clamp (J&P utility patent)



Ord. no. 1334

## Saddle clamp (J&P utility patent)

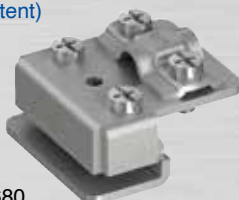

Ord. no. 111 680

## Saddle clamp



Ord. no. 1292

## Saddle clamp "Flex"



Ord. no. 1262



Ord. no. 1266

## Cross-saddle clamp



Ord. no. 1297



Ord. no. 1296

## Saddle clamps

**Multi-Plus** metal sheet terminal and connection clamp. Same connection configurations as the original Multi-clamp with guaranteed 10 cm<sup>2</sup> contact surface, clamping range up to 8 mm.

Specification	Carriage bolt with nut	Fit	PU	Ord. no.
Steel, hot galvanized	Steel, hot galvanized	ø 8-10 mm	50	111 270
Steel, hot galvanized	Stainless steel V2A	ø 8-10 mm	50	111 270 S
Aluminium 4 mm	Steel, hot galvanized	ø 8 mm	50	111 271
Aluminium 4 mm	Stainless steel V2A	ø 8 mm	50	111 271 S
Copper	Coppered	ø 8 mm	50	111 272
Stainless steel V2A	Stainless steel V2A	ø 8-10 mm	50	111 273
Bimetal aluminium/copper	Stainless steel V2A	ø 8 mm	50	111 274

All specifications also available with ø 4-6 mm clamping range

**Saddle clamp** with guaranteed 10 cm<sup>2</sup> contact surface for metal sheet connections. **Clamping range up to 5 mm.**

Specification	Fit	PU	Ord. no.
Steel, hot galvanized	ø 8-10 mm	50	1334
Copper	ø 8-10 mm	50	1336
Aluminium/stainless steel V2A	ø 8-10 mm	50	1335

**Saddle clamp** for secure contact connection to metal sheets and steel constructions. **Clamping range up to 6 mm.**

Specification	Fit	PU	Ord. no.
Steel, hot galvanized	ø 8-10 mm	50	111 680
Copper	ø 8-10 mm	50	111 681
Aluminium/Stainless steel V2A	ø 8 mm	50	111 682
Stainless steel V2A	ø 8-10 mm	50	111 683
Bimetal copper/aluminium	ø 8 mm	50	111 684

**Saddle clamp** for the connection to saddles, lengthwise and crosswise conductor connection. **Clamping range up to 5 mm.**

Specification	Fit	PU	Ord. no.
Steel, hot galvanized	ø 8-10 mm	50	1292
Copper	ø 8-10 mm	50	1293
Stainless steel V2A	ø 8-10 mm	50	910 105
Aluminium	ø 8-10 mm	50	1263

With clamping jaw on request.

**Saddle clamp "Flex"** with one screw M8 and connection clamp for 6 mm<sup>2</sup> (ø 2.8 mm) - 50 mm<sup>2</sup> (ø 8 mm) for clamping on the sheet metal seam

Connection clamp at top	Clamping range	Fit	PU	Ord. no.
NEW! Steel, hot galvanized / Stainless steel V2A	up to 8 mm	6 mm <sup>2</sup> (ø 2.8 mm) - 50 mm <sup>2</sup> (ø 8 mm)	50	1261
NEW! Stainless steel V2A	up to 8 mm	6 mm <sup>2</sup> (ø 2.8 mm) - 50 mm <sup>2</sup> (ø 8 mm)	50	1262

Connection clamp lateral	Clamping range	Fit	PU	Ord. no.
NEW! Steel, hot galvanized / Stainless steel V2A	up to 8 mm	6 mm <sup>2</sup> (ø 2.8 mm) - 50 mm <sup>2</sup> (ø 8 mm)	50	1265
NEW! Stainless steel V2A	up to 8 mm	6 mm <sup>2</sup> (ø 2.8 mm) - 50 mm <sup>2</sup> (ø 8 mm)	50	1266

**Cross-saddle clamp** mounted with four cylinder head screws M6 V2A. Upper part securely riveted, for lengthwise and crosswise conductor connection. **Clamping range up to 8 mm.**

Specification	Fit	PU	Ord. no.
Steel, hot galvanized	ø 8 mm	50	1297
Copper	ø 8 mm	50	1298
Stainless steel V2A	ø 8 mm	50	1299
Aluminium	ø 8 mm	50	1264
Zinc die-cast <b>clamping range max. 5 mm</b>	ø 8-10 mm	50	1296



## Multi-Mini-saddle clamp - slim specification

For connection of conductors with sheets and folds

### Benefits:

- For connection of cables with sheets and profiles up to 8 mm.
- For conductors from 6 mm<sup>2</sup> to 50 mm<sup>2</sup> (ø 2.8 mm - ø 8 mm).
- Suitable for lengthwise and crosswise conductor installation.
- Also suitable for potential equalization applications.

**Multi-Mini-saddle clamp** for equipotential bonding.  
Suitable for lengthwise and crosswise installation. Clamping range up to ø 8 mm.

Specification	Fit	PU	Ord. no.
Stainless steel V2A	6 mm <sup>2</sup> (ø 2.8 mm) - 50 mm <sup>2</sup> (ø 8 mm)	100	111 780
Stainless steel V2A/coppered	6 mm <sup>2</sup> (ø 2.8 mm) - 50 mm <sup>2</sup> (ø 8 mm)	100	111 781
Steel, hot galvanized	6 mm <sup>2</sup> (ø 2.8 mm) - 50 mm <sup>2</sup> (ø 8 mm)	100	111 782

## Attic - saddle clamp

for connection of the down conductor with the attic sheet without damaging the drip edge

### Benefits:

- Connection clamp for secure mounting of an attic sheet.
- Simple installation.
- No damaging or flattening of the drip edge.
- Particularly advantageous if the clamp needs to be repositioned.

**Attic - saddle clamp**  
for connection of the down conductor with the attic sheet without damaging the drip edge

Specification	Fit	PU	Ord. no.
Steel, hot galvanized	ø 8-10 mm	50	111 666
Aluminium	ø 8 mm	50	111 667
Stainless steel V2A	ø 8-10 mm	50	111 669

## Multi-Plus-saddle clamp

### Benefits:

- Lengthwise or crosswise conductor leading possible on top of the standing seam.
- 10 cm<sup>2</sup> contact surface on the standing seam or sheet.

**Multi-Plus-saddle clamp** with bracket and **double terminal clamp**. For connecting saddles and sheets lengthwise and crosswise conductor leading. Clamping range up to 8 mm

Specification	Fit	PU	Ord. no.
Steel, hot galvanized	ø 8-10 mm	25	111 880
Aluminium	ø 8 mm	25	111 881
Copper	ø 8 mm	25	111 882
Stainless steel V2A	ø 8-10 mm	25	111 883

### Additional Benefit:

- For another conductor leading along the standing seam (e.g. down conductor)

**Multi-Plus-saddle clamp** with bracket and **2 double terminal clamps**. For connecting saddles and sheets lengthwise and crosswise conductor leading. Clamping range up to 8 mm

Specification	Fit	PU	Ord. no.
Steel, hot galvanized	ø 8-10 mm	25	111 870
Aluminium	ø 8 mm	25	111 871
Copper	ø 8 mm	25	111 872
Stainless steel V2A	ø 8-10 mm	25	111 873

## Multi-Mini-saddle clamp



Ord. no. 111 780

Application example:



## Attic - saddle clamp



Ord. no. 111 666

Application example:



## Multi-Plus saddle clamp



Ord. no. 111 882



Ord. no. 111 870



## PV-connector



Ord. no. 111 813

Ord. no. 111 812

Ord. no. 111 811

## Terminal clamp



Ord. no. 111 685

## Terminal clamp



Ord. no. 111 381

## Terminal clamp



Ord. no. 1379

Ord. no. 1479

## Terminal clamp



Ord. no. 111 376

## Parallel - saddle clamp



Ord. no. 1295

100

## PV-connector for equipotential bonding

**PV-connector "Flex"** for equipotential bonding; for round conductors of different cross sections and materials; with hammer head bolt and locking nut M8.

Specification	Clamping range	Fit	PU	Ord. no.
<b>NEW</b> Stainless steel V2A	Profile 28/15	6 mm <sup>2</sup> (ø 2.8 mm) - 50 mm <sup>2</sup> (ø 8 mm)	100	111 813

**PV-connector** for equipotential bonding; for round conductors ø 8 mm; with hammer head bolt M8 for profile 28/15 and locking nut.

Specification	Clamping range	Fit	PU	Ord. no.
<b>NEW</b> Aluminium/Stainless steel V2A	Profile 28/15	ø 8 mm	100	111 812

**PV-connector** for equipotential bonding; for round conductors ø 8 mm; through-hole Ø 9 (for fixing screw M8) for customized installation versions.

Specification	Clamping range	Fit	PU	Ord. no.
<b>NEW</b> Aluminium	Customized	ø 8 mm	100	111 811

## Terminal clamp

**Terminal clamp** for the secure contact connection to metal sheets and steel constructions.

Specification	Clamping range	Fit	PU	Ord. no.
Steel, hot galvanized	1 - 5 mm	ø 6-8 mm	50	111 685
Copper	1 - 5 mm	ø 6-8 mm	50	111 686
Aluminium/stainless steel V2A	1 - 5 mm	ø 6-8 mm	50	111 687
Stainless steel V2A	1 - 5 mm	ø 6-8 mm	50	111 688
Bimetal copper/stainless steel V2A	1 - 5 mm	ø 6-8 mm	50	111 689

**Terminal clamp** for steel constructions. Lengthwise and crosswise connections possible.

Specification	Clamping range	Fit	PU	Ord. no.
Steel, hot galvanized	5 - 18 mm	ø 8-10 mm	25	111 381
Stainless steel V2A	5 - 18 mm	ø 8-10 mm	25	111 382

**Terminal clamp** for steel constructions. Lengthwise and crosswise connections possible.

Specification	Clamping range	Fit	PU	Ord. no.
<b>Terminal clamp with KS-Connector</b>				
Steel, hot galvanized	5 - 18 mm	ø 6-10 mm	25	1379
Steel, hot galvanized	18 - 35 mm	ø 6-10 mm	25	111 379
Stainless steel V2A	5 - 18 mm	ø 6-10 mm	25	2002
Stainless steel V2A	18 - 35 mm	ø 6-10 mm	25	111 380

Specification	Clamping range	Fit	PU	Ord. no.
<b>Terminal clamp with clamping jaw</b>				
Steel, hot galvanized	5 - 18 mm	ø 8-10 mm	25	1479
Steel, hot galvanized	18 - 35 mm	ø 8-10 mm	25	111 779

**Terminal clamp** for steel constructions. Lengthwise and crosswise connections possible.

Specification	Clamping range	Fit	PU	Ord. no.
Steel, hot galvanized	bis 12 mm	ø 8-10 mm	50	111 376
Red brass	bis 12 mm	ø 8-10 mm	50	1377

**Parallel - saddle clamp**, special clamp for snowload-safe installation of the down conductor along the saddle. Clamping range up to 4 mm.

Specification	Fit	PU	Ord. no.
Aluminium	ø 8 mm	50	1295

## Terminal clamp, heavy-duty type

- Secure contact connections to steel constructions with up to 52 mm clamping range.
- Variable connections through rotating terminal lugs (360°).
- Connection with KS-Connector, Vario-clamp or with perforated strip possible.

Specification	Clamping range	Fit	PU	Ord. no.
<b>Terminal clamp (heavy-duty type) with terminal lug (bore hole ø 11 mm)</b>				
Steel, hot galvanized	5 - 19 mm		25	111 384
Steel, hot galvanized	19 - 36 mm		25	111 385
Steel, hot galvanized	36 - 52 mm		20	111 386
Stainless steel V2A	5 - 19 mm		25	111 387
Stainless steel V2A	19 - 36 mm		25	111 388
Stainless steel V2A	36 - 52 mm		20	111 389

Specification	Clamping range	Fit	PU	Ord. no.
<b>Terminal clamp (heavy-duty type) with double terminal clamp</b>				
Steel, hot galvanized	5 - 19 mm	ø 8-10 mm	25	111 884
Steel, hot galvanized	19 - 36 mm	ø 8-10 mm	25	111 885
Steel, hot galvanized	36 - 52 mm	ø 8-10 mm	25	111 886
Stainless steel V2A	5 - 19 mm	ø 8-10 mm	25	111 887
Stainless steel V2A	19 - 36 mm	ø 8-10 mm	25	111 888
Stainless steel V2A	36 - 52 mm	ø 8-10 mm	25	111 889

**Terminal clamp "Perfekt" heavy-duty type**, with 2 clamping jaws  
connections possible horizontally and vertically in any direction.

Specification	Clamping range	Fit	PU	Ord. no.
Stahl/verzinkt	5 - 19 mm	ø 8-10 mm	25	111 854
Stahl/verzinkt	19 - 36 mm	ø 8-10 mm	25	111 855
Stahl/verzinkt	36 - 52 mm	ø 8-10 mm	20	111 856
Edelstahl V2A	5 - 19 mm	ø 8-10 mm	25	111 857
Edelstahl V2A	19 - 36 mm	ø 8-10 mm	25	111 858
Edelstahl V2A	36 - 52 mm	ø 8-10 mm	20	111 859

## Terminal disconnecting clamp, heavy-duty type

### Benefits:

- Optimized tight fit with the open-end wrench due to the patented cylindrical part of the Vario-clamp top part.
- For safe contact connection of round conductors or sheets to steel constructions with a material thickness up to 52 mm.
- Economical solution – connecting bracket and disconnecter in one component.

### Terminal disconnecting clamp, heavy-duty type

for test joints of ø 8-10 mm or flat 30 mm

Specification	Clamping range	Fit	PU	Ord. no.
Steel, hot galvanized	5 - 19 mm	fl. 30 mm	25	111 734
Steel, hot galvanized	19 - 36 mm	fl. 30 mm	25	111 735
Steel, hot galvanized	36 - 52 mm	fl. 30 mm	20	111 736
Stainless steel V2A	5 - 19 mm	fl. 30 mm	25	111 737
Stainless steel V2A	19 - 36 mm	fl. 30 mm	25	111 738
Stainless steel V2A	36 - 52 mm	fl. 30 mm	20	111 739
Steel, hot galvanized	5 - 19 mm	ø 8-10 mm	25	111 784
Steel, hot galvanized	19 - 36 mm	ø 8-10 mm	25	111 785
Steel, hot galvanized	36 - 52 mm	ø 8-10 mm	20	111 786
Stainless steel V2A	5 - 19 mm	ø 8-10 mm	25	111 787
Stainless steel V2A	19 - 36 mm	ø 8-10 mm	25	111 788
Stainless steel V2A	36 - 52 mm	ø 8-10 mm	20	111 789

### Terminal clamp, heavy-duty type



Ord. no. 111 388

Ord. no. 111 887

### Terminal clamp "Perfect" heavy-duty type



Ord. no. 111 859

### Terminal disconnecting clamp, heavy-duty type



Ord. no. 111 737

Ord. no. 111 788



## Bimetallic product series (J.P. patent)

The "right" connection between different materials. J. Pröpster offers a conform to standards clamping system, which is tested and practice-oriented. It provides a practical and economical way of joining and connecting different materials: copper, hot galvanized steel, aluminium, etc.

- Benefits:**
- Simple handling – no messing about with self-made bimetallic strips.
  - Corrosion-free connections between copper wires and wires made of other materials (e.g. steel, aluminium).
  - Corrosion-free connections between copper wires and components made of other materials
    - earth lead-in rods
    - test joints
    - skylights
    - metal constructions

### Bimetal Multi-clamp three-part

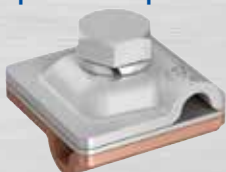

Ord. no. 1274

### Bimetal connection Vario-clamp

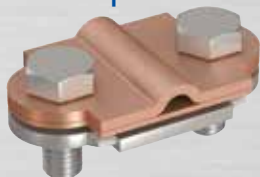

Ord. no. 1342 Z

### Bimetal Vario-clamp M8-Plus



Ord. no. 111 727

### Bimetallic bush and bimetallic strip



Ord. no. 1051

Ord. no. 1052



Ord. no. 1053

### Bimetallic terminal clamp



Ord. no. 111 689

**Bimetal Multi-clamp, three-part, upper piece:** aluminium.  
**intermediate plate:** bimetal aluminium/copper. **bottom piece:** copper.

Specification	Fit	PU	Ord. no.
Multi-connection clamp aluminium/copper	ø 8 mm	100	1274
Multi-Plus-connection clamp aluminium/copper with guaranteed 10 cm <sup>2</sup> contact surface. (picture on page 89)	ø 8 mm	50	111 274

### Bimetal Vario-clamp

with screws M10, made of material 40x4 mm.

Specification	Fit	PU	Ord. no.
Round copper on flat steel, hot galvanized	ø 8-10/ fl. 30 mm	50	1342 Z
Round copper on round (ø 16) steel, hot galvanized	ø 8-10/ø 16 mm	50	1348 Z
Round copper on round/flat steel, hot galvanized	ø 16/fl. 30/ø 8-10 mm	50	1349 Z
Round copper on round steel, hot galvanized	ø 8-10/ø 8-10 mm	50	1343 Z

### Bimetal Vario-clamp M8-Plus

with screws M8, made of material 30x3 mm.

Specification	Fit	PU	Ord. no.
Round copper on flat steel, hot galvanized	ø 8-10/ fl. 30 mm	50	111 727
Round copper on round (ø 16) steel, hot galvanized	ø 8-10/ø 16 mm	50	111 728
Round copper on round/flat steel, hot galvanized	ø 16/fl. 30/ø 8-10 mm	50	111 729
Round copper on round steel, hot galvanized	ø 8-10/ø 8-10 mm	50	111 726

### Bimetallic bush and strip

for corrosion resistant connections between steel/aluminium and copper.

Specification	Length	Fit	PU	Ord. no.
Aluminium outside/ copper inside	40 mm	ø 8 mm	100	1051
Aluminium inside/ copper outside	40 mm	ø 8 mm	100	1052
Bimetallic strip, 40 mm wide; 0.5 mm thick	500 mm	---	1	1053

**Bimetallic terminal clamp** for the secure contact connection to metal sheets and steel constructions.

Specification	Clamping range	Fit	PU	Ord. no.
Wire clamp - stainless steel V2A	1 - 5 mm	ø 6-8 mm	50	111 689
Terminal clamp - copper				



**Bimetal gutter clamp** for secure contact connections between different materials on gutters. Maximum safety due to perfect clamping; no bead damage.

Specification	Fit	PU	Ord. no.
Wire clamp - <b>stainless steel V2A</b>	ø 6-8 mm	25	111 674
Bead clamp - <b>copper</b>	Bead max. ø 20 mm		

**Bimetal gutter clamp** for secure contact connections between different materials on gutters. Maximum safety due to perfect clamping; no bead damage.

Specification	Fit	PU	Ord. no.
Wire clamp - <b>stainless steel V2A</b>	ø 6-8 mm	50	111 679
Bead clamp - <b>copper</b>	Bead max. ø 20 mm		

**Bimetal gutter connection clamp DUO**  
to connect air termination conductors and down conductors with gutters.

Specification	Fit	PU	Ord. no.
Wire clamp - <b>aluminium</b> ;	ø 8 mm	25	1307 Z
Bead clamp - <b>copper</b>	Bead ø 15-20 mm		

**Bimetal gutter clamp upper piece:** Aluminium,  
**intermediate plate:** Bimetall Al/Cu, **bottom piece:** both components copper.

Specification	Fit	PU	Ord. no.
Wire clamp <b>aluminium</b> ;	ø 8 mm	50	1300 Z
Bead clamp <b>copper</b>	Bead ø 10-20 mm		

**Bimetal saddle clamp**, for the connection between different materials.

Specification	Fit	PU	Ord. no.
for wire connections ø 8-10 mm <b>aluminium</b> ; on saddles up to 6 mm <b>copper</b>	ø 8-10 mm	50	1290 Z
for wire connections ø 8-10 mm <b>copper</b> on saddles up to 6 mm steel, hot galvanized or <b>aluminium</b>	ø 8-10 mm	50	1297 Z

**Bimetal Saddle clamp** for secure contact connection to metal sheets and steel constructions. **Clamping range up to 6 mm.**

Specification	Fit	PU	Ord. no.
Wire clamp <b>aluminium</b> ;	ø 8 mm	50	111 684
Saddle clamp <b>copper</b>			

## Bimetal gutter clamp - ideal



Ord. no. 111 674

## Bimetal gutter clamp - slim



Ord. no. 111 679

## Bimetal gutter connection clamp DUO



Ord. no. 1307 Z

## Bimetal gutter clamp



Ord. no. 1300 Z

## Bimetal saddle clamp



Ord. no. 1290 Z

## Bimetal saddle clamp (J.P. utility patent)



Ord. no. 111 680



## Rod clamp



Ord. no. 1312

## Snow guard clamp



Ord. no. 1311

## Clamping shoe



Ord. no. 111 365



Ord. no. 1397



Ord. no. 111 364

## Rod clamp

for connection of round conductors  $\varnothing$  8-10 mm and rods  $\varnothing$  16 and 20 mm.

Specification	Fit	PU	Ord. no.
Steel, hot galvanized	$\varnothing$ 8-10 / $\varnothing$ 16 mm	50	1312
Steel, hot galvanized	$\varnothing$ 8-10 / $\varnothing$ 20 mm	50	1313
Stainless steel V2A	$\varnothing$ 8-10 / $\varnothing$ 16 mm	50	1314
Stainless steel V2A	$\varnothing$ 8-10 / $\varnothing$ 20 mm	50	1315



## Snow guard clamp, mounted with cylinder head screws M6 V2A.

Specification	Fit	PU	Ord. no.
Aluminium/stainless steel V2A	$\varnothing$ 8-10 mm	50	1311
Copper	$\varnothing$ 8-10 mm	50	1310

## Clamping shoe, according to EN 62561-1

with one elongated hole  $\varnothing$  9 x 12 mm for screwing on and four holes  $\varnothing$  5.2 mm for riveting!

Specification	Fit	PU	Ord. no.
Steel, hot galvanized	$\varnothing$ 8 mm	100	1365
Copper	$\varnothing$ 8 mm	100	111 366
Aluminium	$\varnothing$ 8 mm	100	111 365
Stainless steel V2A	$\varnothing$ 8 mm	100	111 362



## Clamping shoe, according to EN 62561-1

with one hole  $\varnothing$  10.5 mm for screwing on.

Specification	Fit	PU	Ord. no.
Steel, hot galvanized	$\varnothing$ 8 mm	100	1395
Aluminium	$\varnothing$ 8 mm	100	1397
Stainless steel V2A	$\varnothing$ 8 mm	100	111 363



## Clamping shoe, according to EN 62561-1

with one hole  $\varnothing$  11 mm for screwing and hexagon bolts M8.

Specification	Fit	PU	Ord. no.
Cast/hot galvanized	$\varnothing$ 8-10 mm	100	111 364





**Bridging bracket** for the connection of metal structural claddings  
(Hole pattern: 4x ø 6.5 mm; 8x ø 5.2 mm)

Specification	Length	PU	Ord. no.
Aluminium	250 mm	100	1369
Aluminium	350 mm	100	111 403
Copper	250 mm	100	1370
Aluminium with centre hole ø 10.5 mm	250 mm	100	111 404
Aluminium with centre hole ø 10.5 mm	350 mm	100	111 402

**Bridging cable**, highly flexible, for the connection of metal structural claddings or as expansion piece 16 mm<sup>2</sup>. Copper with aluminium cable lug; pressed airtight.

Specification	Length	PU	Ord. no.
For screws M8	400 mm	50	1371
Copper/aluminium	300 mm	100	1372
For screws M10	400 mm	50	1373
Copper/aluminium	300 mm	100	1374

Additional cable types, lengths, cross sections and hole patterns on request.

**Bridging cable set**, highly flexible bridging cable set 16 mm<sup>2</sup> for the connection of metal structural claddings, with Multi-Plus clamping jaws (ø 8 mm / flat).

Specification	Length	PU	Ord. no.
Cable copper/aluminium with	400 mm	25	910 096
two stainless steel V2A - clamps	300 mm	25	910 096 S

Additional cable types, lengths, cross sections and hole patterns on request.

**Bridging braid**, highly flexible, for the connection of metal structural claddings or as expansion piece (50 mm<sup>2</sup>). (Hole pattern: 4x ø 6.5 mm; 8x ø 5.1 mm; 2x ø 10.5 mm).

Specification	Length	PU	Ord. no.
Copper	180 mm	100	1375
Aluminium	180 mm	100	1376
Aluminium with central hole ø 10 mm	300 mm	100	911 688

Additional lengths and hole patterns on request.

**Expansion piece**, for the compensation of the temperature-dependent change in length of air termination conductors, e.g. connection with two multi clamps.

Specification	Length	Fit	PU	Ord. no.
Aluminium AlMgSi 0.5	600 mm	ø 8 mm	25	1380
Copper	600 mm	ø 8 mm	25	911 178

**Drilling screw and blind rivet**

Specification	Dimensions	PU	Ord. no.
<b>Drilling screw DIN 7504 Form K, hexagonal SW 10 mm</b>			
Stainless steel V2A	ø 6.3x19 mm	1	7504 6,3X19 V2A
<b>Blind rivet DIN 7337</b>			
Stainless steel V2A/Aluminium	ø 5.0x12 mm	1	7337 5,0X12 ALU/V2A
Stainless steel V2A	ø 5.0x12 mm	1	7337 5,0X12 V2A/V2A

Additional dimensions on request.

## Bridging bracket



Ord. no. 1369

Ord. no. 111 404

## Bridging cable



Ord. no. 1371

## Bridging cable set



Ord. no. 910 096

## Bridging braid

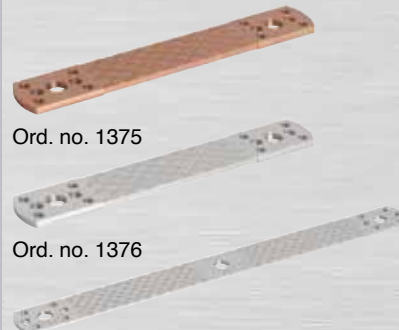

Ord. no. 1375

Ord. no. 1376

Ord. no. 911 688

## Expansion piece



Ord. no. 1380

## Drilling screw and blind rivet



Ord. no. 7504 6,3X19 V2A

Ord. no. 7337 5,0X12 V2A/V2A

Connection and terminal clamps



## Number plate

### Type A



Ord. no. 111 624



Example of application:

Ord. no. 1056

### Type B



Ord. no. 111 640

### Type C

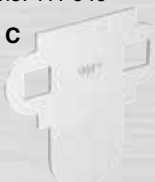

Ord. no. 111 620

### Type D



Ord. no. 111 639



Ord. no. 111 629

## Connection set for safety rope systems



Ord. no. 111 348

Ord. no. 111 338



Ord. no. 111 343

## Number plate

### Number plate

marking of test joints at conductors and bars. Indicate the desired numbers on your order.

Specification	Fit	PU	Ord. no.
<b>Type A:</b> Number plate, <b>without numbers</b> , for flexible use with hand punches.			
Aluminium	ø 8-10 mm	100	111 624
Aluminium	ø 16 mm	200	111 625
Aluminium	fl. 30 mm	100	111 626
Copper	ø 8-10 mm	100	111 627
Copper	ø 16 mm	100	111 628
<b>Hand punches 0-9, size 10 mm</b>		1	1059

Specification	Fit	PU	Ord. no.
<b>Type A:</b> Number plate, <b>including stamped in numbers, customised</b>			
Aluminium	ø 8-10 mm	1	1056
Copper	ø 8-10 mm	1	1060

Specification	PU	Ord. no.
<b>Type B:</b> Test plate, with hole spacing of 28 - 38 mm, suitable for number plates		
Aluminium	100	111 640

Specification	PU	Ord. no.
<b>Type C:</b> Test plate, suitable for Vario-Disconnecting clamp.		
Aluminium	100	111 620
Copper	100	111 623

Specification	PU	Ord. no.
<b>Type D:</b> Test plate, for test badge up to ø 50 mm (e. g. <b>VDB-test badge</b> ) with hole spacing of 28 - 38 mm, suitable for Vario-Disconnection clamp M8-Plus		
Stainless steel V2A	100	111 639

Specification	PU	Ord. no.
Test badge ø 30 mm		
Test badge with company logo on request.		
	20	111 629

## Connection set for safety rope systems

Connection set for safety rope systems to connect existing safety rope systems on roofs to the existing air termination system of the lightning protection system

Specification	Rope length	Fit		PU	Ord. no.
		Rope	Lightning protection		
Stainless steel V2A	0.5 m	ø 6 mm	ø 8 - 10 mm	50	111 346
Stainless steel V2A	1.0 m	ø 6 mm	ø 8 - 10 mm	50	111 347
Stainless steel V2A	0.5 m	ø 8 mm	ø 8 - 10 mm	50	111 348
Stainless steel V2A	1.0 m	ø 8 mm	ø 8 - 10 mm	50	111 349
Stainless steel V2A	0.5 m	ø 10 mm	ø 8 - 10 mm	50	111 340
Stainless steel V2A	1.0 m	ø 10 mm	ø 8 - 10 mm	50	111 350

### Rope safeguarding clamp,

with carriage bolts and nuts **without** rope and clamping jaw

Specification	Fit	PU	Ord. no.
Stainless steel V2A	ø 6 mm	10	111 336
Stainless steel V2A	ø 8 mm	10	111 338
Stainless steel V2A	ø 10 mm	10	111 335

### Connection cable,

with clamping jaw ø 8 - 10 mm **without** rope safeguarding clamp

Specification	Rope length	Cross section	PU	Ord. no.
Rope / clamping jaw / clamping shoe				
Copper / stainless steel V2A / aluminium	0.5 m	16 mm <sup>2</sup>	10	111 342
Copper / stainless steel V2A / aluminium	1.0 m	16 mm <sup>2</sup>	10	111 343

## Pipe clamp

**Universal downpipe clamp** (cutting to length as needed) - with holes  $\varnothing$  10.5 mm, hexagonal screw M8 and nut. **Benefit:** Only two types, for all common diameters of downpipes.

Specification	Fit	PU	Ord. no.
Steel, hot galvanized	$\varnothing$ 60/65/70/75/80/85/90/95/100/110/120 mm	25	111 214
Aluminium	$\varnothing$ 60/65/70/75/80/85/90/95/100/110/120 mm	25	111 212
Copper	$\varnothing$ 60/65/70/75/80/85/90/95/100/110/120 mm	25	111 210
Stainless steel V2A	$\varnothing$ 60/65/70/75/80/85/90/95/100/110/120 mm	25	111 216
Steel, hot galvanized	$\varnothing$ 90/95/100/110/120/125/130/140/150 mm	25	111 215
Aluminium	$\varnothing$ 90/95/100/110/120/125/130/140/150 mm	25	111 213
Copper	$\varnothing$ 90/95/100/110/120/125/130/140/150 mm	25	111 211
Stainless steel V2A	$\varnothing$ 90/95/100/110/120/125/130/140/150 mm	25	111 217

**NEW:** also for intermediate diameters  
Additional diameters on request.

Example of application:



**Downpipe clamp**, hexagonal screw M8 and nut, according to EN 62561-1.

Specification	Fit	PU	Ord. no.
Steel, hot galvanized	$\varnothing$ 100 mm	25	111 100
Steel, hot galvanized	$\varnothing$ 120 mm	25	111 120
Copper	$\varnothing$ 100 mm	25	111 205
Copper	$\varnothing$ 120 mm	25	111 207

Additional dimensions with fixed measurements on request!

**Conductor fastener** for insulated mounting of earth lead-in rods and terminal lugs to the downpipes.

Specification	Fit of holder	PU	Ord. no.
Stainless steel V2A	$\varnothing$ 16 mm	50	111 396
<b>Benefits:</b> universally mountable to the downpipe conductor fasteners with hexagonal screw M8 (e.g. ord. no. 111 213, 111 120 or 111 391).	$\varnothing$ 8 - 10 mm	50	111 397
	fl. 30 mm	50	111 398
	$\varnothing$ 13 mm	50	111 399

Example of application:



## Inspection doors

**Inspection doors** to be used for flush-mounted test joints.

Specification	Mounting dimensions	PU	Ord. no.
Steel, hot galvanized, stamped	155 x 205 mm	1	1044
Stainless steel V2A, stamped	155 x 205 mm	1	1040
Steel, hot galvanized, stamped	140 x 250 mm	1	1041
Stainless steel V2A, stamped	140 x 250 mm	1	1045
Steel, hot galvanized for square spanner	150 x 200 mm	1	1054

## Universal downpipe clamp



Ord. no. 111 212

## Downpipe clamp



Ord. no. 111 100

## Conductor fastener



Ord. no. 111 396

Ord. no. 111 398

## Inspection doors

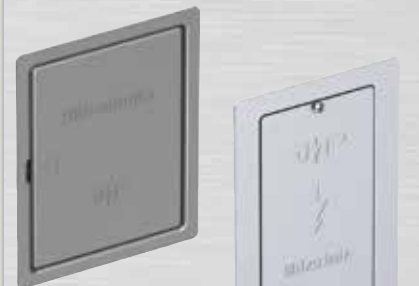

Ord. no. 1044

Ord. no. 1045



## Test joint box

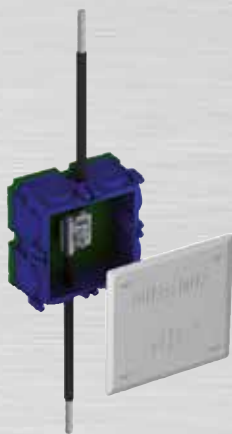

Ord. no. 111 580

## Earth electrode inspection housing



Ord. no. 1055

Ord. no. 1055 S1

## Test joint box



Ord. no. 111 585



Ord. no. 111 587



Note: Test joint box with built-in equipotential bonding bar to be found on page 132.

## Test joint box

**Test joint box** to be used for flush-mounted fitting and installation in concrete with integrated test joint and flexible connection cable for round conductor  $\varnothing$  8-10 mm or flat strips.

Specification	PU	Ord. no.
<b>Test joint box</b> made of unbreakable plastic 142 x 142 x 70 mm with built-in test joint and flexible insulated connection rope. Cover made of <b>stainless steel V2A</b>	1	111 580

Example of application:

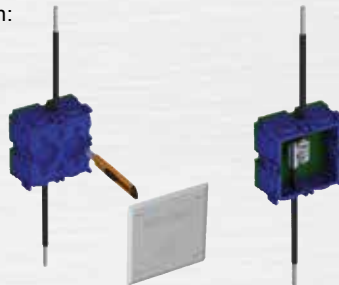

## Earth electrode inspection housing

for underfloor installation. Heavy-duty type - can be driven over.

Specification	Mounting dimensions	PU	Ord. no.
Grey cast iron black varnished; opening: oval without test joint	230 x 150 x 120 mm	1	1055
with built-in test joint	230 x 150 x 120 mm	1	1043

**Stainless steel V2A**; opening: rectangular; **V2A**-cover; material thickness: **6 mm**

without test joint	260 x 210 x 120 mm	1	1055 S1
with built-in test joint	260 x 210 x 120 mm	1	1043 S1

**Test joint box for flush-mounted installation** on facades with external thermal insulation composite systems with the option of adjustment the installation depth.

Specification	Installation depth	PU	Ord. no.
Test joint box plastic (196 x 158 mm) low version, <b>without</b> test joint. Conductor insert/perforations: round conductor: up to $\varnothing$ 14.5 mm and strips: flat up to 30 x 5.0 mm Incl. <b>V2A</b> cover (220 x 180 mm) with neopren sealing, plaster cover and installation set.	90 - 140 mm	1	111 585
Test joint box plastic (196 x 158 mm) high version with removable spacer, insulation material, <b>without</b> test joint Conductor insert/perforations: Specification acc. to ord. no. 111 585	130 - 320 mm	1	111 588
Test joint box plastic (196 x 158 mm) high version with removable spacer, insulation material, and <b>built-in</b> test joint. Suitable for the connection of: round conductor: up to $\varnothing$ 14.5 mm and strips: flat up to 30 x 5.0 mm Incl. <b>V2A</b> cover (220 x 180 mm) with neopren sealing, plaster cover and installation set.	130 - 320 mm	1	111 587

The plastic is self-extinguishing and halogen-free. The **V2A** cover meets protection class IP65

Spacer with insulation (ord. no. 111 589 ) is available in single units. Price on request.

Cover with company logo on request

Example of application:

Spacer (from Ord. no. 111 588)





# Earthing material



Earthing material



## Steel grid panel

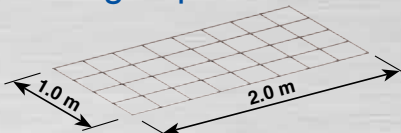

Ord. no. 912 125

## Connection- and Terminal clamp



Ord. no. 111 313

Ord. no. 111 319

## Clamping piece



Ord. no. 1321 S

## Spacer



Ord. no. 1319

## Sign and protective cap



Ord. no. 102 220





Ord. no. 102 219

## Protection measures against step voltages in shelter hats

Steel grid panel as protection against step voltage.

Specification	Mesh size	Dimensions (L x W)	PU	Ord. no.
Stainless steel V4A (ø 4 mm)	250 x 250 mm	2.0 m x 1.0 m	1	912 125 

Connection- / terminal clamp completely made of stainless steel V4A for steel grid panels.

Specification	Fit	PU	Ord. no.
Connection clamp: Multi-Mini	ø 4-6 / ø 4-6 mm	100	111 313 
Terminal clamp: Multi-Mini	ø 10 / ø 4-6 mm	50	111 319 

Clamping piece suitable for round conductors as a distance holder for installing foundation earth electrodes. **Benefits:** Infinitely adjustable height for different foundations (soil, blinding layer).

Specification	Fit	PU	Ord. no.
Steel, bare	ø 10 mm / fl. 30 x 3.5 mm	50	1321
Steel, hot galvanized	ø 10 mm / fl. 30 x 3.5 mm	50	1321 S

Example of application:



Distance pin: reinforcement iron ø 10 mm or wire ø 10 mm

Blinding layer of concrete

Spacer, for foundation earth electrodes.

Suitable for ø 10 mm round conductors or 30 x 3.5 mm strip.

Specification	Length	PU	Ord. no.
Steel, hot galvanized	280 mm	50	1319

Sign "ACHTUNG! Blitzschutz/Erdung" and Protective cap for terminal lugs

Specification	Length	Fit	PU	Ord. no.
Sign PVC (printed on both sides)	200 x 50 mm	up to ø 10 mm or up to flat 40 x 4 mm	10	102 220

With company logo imprint upon request

Protective cap plastic yellow	ø 10 mm or fl. 30 x 3.5 mm	50	102 219
-------------------------------	----------------------------	----	---------

Application with ground strap:



Application with ground wire:





## Earth lead-in rods

Earth lead-in rods, according to EN 62561-2,  $\varnothing$  16 mm, with chamfered edges.

Specification	Length	Fit	PU	Ord. no.
Steel, hot galvanized	750 mm	$\varnothing$ 16 mm	10	100 750
Steel, hot galvanized	1000 mm	$\varnothing$ 16 mm	10	101 000
Steel, hot galvanized	1200 mm	$\varnothing$ 16 mm	10	101 200
Steel, hot galvanized	1500 mm	$\varnothing$ 16 mm	10	101 500
Steel, hot galvanized	2000 mm	$\varnothing$ 16 mm	10	101 002
<b>E-Copper</b>	1000 mm	$\varnothing$ 16 mm	10	<b>101 005</b>
<b>E-Copper</b>	1200 mm	$\varnothing$ 16 mm	10	<b>101 205</b>
<b>E-Copper</b>	1500 mm	$\varnothing$ 16 mm	10	<b>101 505</b>
Stainless steel V2A	1000 mm	$\varnothing$ 16 mm	10	102 005
Stainless steel V2A	1200 mm	$\varnothing$ 16 mm	10	102 205
Stainless steel V2A	1500 mm	$\varnothing$ 16 mm	10	102 505
Stainless steel V4A	1000 mm	$\varnothing$ 16 mm	10	103 137
Stainless steel V4A	1200 mm	$\varnothing$ 16 mm	10	102 207
Stainless steel V4A	1500 mm	$\varnothing$ 16 mm	10	910 347

Connection clamps for earth lead-in rods see page 119.

**Earth lead-in rods** with terminal lug for connecting down conductors to the earth termination system, corrosion resistant type, shrink-on tube insulated earth entry.

Specification	Fit / Length	PU	Ord. no.
Steel, hot galvanized	$\varnothing$ 16 = 750 / 1000 = $\varnothing$ 10 mm	10	102 075
Steel, hot galvanized	$\varnothing$ 16 = 1000 / 1000 = $\varnothing$ 10 mm	10	102 100
Steel, hot galvanized	$\varnothing$ 16 = 1200 / 1000 = $\varnothing$ 10 mm	10	102 120
Steel, hot galvanized	$\varnothing$ 16 = 1500 / 1000 = $\varnothing$ 10 mm	10	102 150
Stainless steel V4A	30 x 3.5 mm / 2000 mm	10	102 206 S1

Rods also available without insulation.

Note: Insulated down conductor (protection against touch voltage) see page 146.

**Terminal lug**, straightened, with PVC cover, 60 mm is stripped on one side.

Specification	Fit	Length	PU	Ord. no.
Steel, hot galvanized	$\varnothing$ 10 mm	1500 mm	10	102 211
Steel, hot galvanized	$\varnothing$ 10 mm	3200 mm	10	102 212

Additional lengths on request.

**Terminal lug**, stainless steel V4A, straightened.

Specification	Fit	Length	PU	Ord. no.
Stainless steel V4A	$\varnothing$ 10 mm	1500 mm	10	102 213
Stainless steel V4A	$\varnothing$ 10 mm	3200 mm	10	102 214
Stainless steel V4A	30 x 3.5 mm	1500 mm	10	102 233
Stainless steel V4A	30 x 3.5 mm	3200 mm	10	102 234

Additional lengths on request.

**Cross profiled earth rod**, 50x50x3 mm.

Specification	Length	PU	Ord. no.
Steel, hot galvanized	1000 mm	5	110 100
Steel, hot galvanized	1500 mm	5	110 150
Steel, hot galvanized	2000 mm	5	110 200
Steel, hot galvanized	2500 mm	5	110 205
Steel, hot galvanized	3000 mm	5	110 300

Additional lengths on request.

**Earth plate** according to EN 62305-3 Tab. 7.

Specification	Length	PU	Ord. no.
Steel, hot galvanized, with terminal lug	500x500x3 mm	1	110 140
( $\varnothing$ 10 mm, insulated, length 1.5 m)	1000x500x3 mm	1	110 145
<b>Copper</b> , with welded connection	500x500x2 mm	1	<b>110 130</b>
cable (50 mm <sup>2</sup> ; length 1.5 m)	1000x500x2 mm	1	<b>110 135</b>

Additional dimensions on request!

## Earth lead-in rods



Ord. no. 101 000

## Earth lead-in rods



Ord. no. 102 206 S1



Ord. no. 102 075

## Terminal lug



Ord. no. 102 211



Ord. no. 102 213

## Cross profiled earth rod



Ord. no. 110 200

## Earth plate



Ord. no. 110 130

Earthing material



## Diagonal cross clamp



Ord. no. 111 353

## USV-clamp



Ord. no. 111 425

## Multi-clamp ø 10 mm



Ord. no. 1278

## Connection clamp

### Diagonal cross clamp, heavy-duty type

with two screws M10 for T-, cross- and parallel-connections, flat and round.

Specification			Fit	PU	Ord. no.
Steel, hot galvanized	two-part	flat/round	fl. 30 / ø 8-10 mm	50	1354
Steel, hot galvanized		flat/flat	fl. 30 / fl. 30 mm	50	111 352
Steel, hot galvanized		round/round	ø 8-10 / ø 8-10 mm	50	111 353
Steel, hot galvanized		flat/round	fl. 40 / ø 8-10 mm	25	111 354
<b>Stainless steel V2A</b>	two-part	flat/round	fl. 30 / ø 10 mm	50	<b>2008</b>
<b>Stainless steel V2A</b>		flat/flat	fl. 30 / fl. 30 mm	50	<b>2015</b>
<b>Stainless steel V2A</b>		round/round	ø 10 / ø 10 mm	50	<b>2008 S</b>
<b>Stainless steel V4A</b>	two-part	flat/flat	fl. 30 / fl. 30 mm	50	<b>2015 S</b>
<b>Stainless steel V4A</b>		round/flat	ø 10 / fl. 30 mm	50	<b>2008 S1</b>
<b>Stainless steel V4A</b>		round/round	ø 10 / ø 10 mm	50	<b>2008 S2</b>



flat/flat parallel connector



flat/flat cross connector



flat/flat/round parallel cross connector



round/round (ø10mm) cross connector



flat/flat/round parallel connector

### USV - clamp

Easy-to-assemble connection system e.g. for earthing conductors in concrete.

**Benefits:** • considerably shorter and easier installation process • universal use

Specification		Fit	PU	Ord. no.
Steel, hot galvanized	flat/round/flat	30 / ø 8-10 / 30 mm	50	111 425
<b>Stainless steel V2A</b>	flat/round/flat	30 / ø 8-10 / 30 mm	50	<b>111 426</b>



flat/flat connection



flat/flat T-connection



flat/round ø 8-10 parallel connection



flat/flat connection and round T-connection



flat/flat/round cross connection

### Multi-clamp ø 10 mm, heavy-duty type

for universal use as T-, cross- and parallel- connection for conductors ø 10 mm.

Specification	Carriage bolt with nut	Fit	PU	Ord. no.
Steel, hot galvanized	Steel, hot galvanized	ø 10 mm	75	1278
<b>Stainless steel V2A</b>	<b>Stainless steel V2A</b>	ø 10 mm	75	<b>1279</b>
<b>Stainless steel V4A</b>	<b>Stainless steel V4A</b>	ø 10 mm	75	<b>1279 S</b>
<b>Copper</b>	<b>Coppered</b>	ø 10 mm	75	<b>111 280</b>





## Diagonal swivel cross clamp

**Benefits:**

- No clamp disassembly required.
- Easier installation because of swivelling opening.
- Low construction height after installation.
- Two hexagonal screws M10 (wrench width 17) .
- T-, cross-, parallel-, and diagonal- connections are possible.

### Diagonal swivel cross clamp

for a fast and simple connection of round and flat material.

Specification	Fit	PU	Ord. no.
Steel, hot galvanized	fl. 30 / ø 8-10 mm	25	111 790
Steel, hot galvanized	ø 8-10 mm / ø 8-10 mm	25	111 791
Stainless steel V2A	fl. 30 / ø 8-10 mm	25	111 792
Stainless steel V2A	ø 8-10 mm / ø 8-10 mm	25	111 793
Stainless steel V4A	fl. 30 / ø 8-10 mm	25	111 794
Stainless steel V4A	ø 8-10 mm / ø 8-10 mm	25	111 795



round/round (ø10mm)  
cross connector



flat/round  
parallel connector

## Diagonal swivel cross clamp



Ord. no. 111 790



Ord. no. 111 791

## Connecting clamp for reinforcement

**Benefits:**

- Easier installation because of swivelling opening.
- No clamp disassembly required.
- Large clamping area flat/round (Ø 10 / fl. 40 mm) is possible with the reinforcement (up to Ø 40 mm).
- T-, cross-, parallel-, and diagonal- connections are possible.

Connecting clamp for reinforcement for the fast and easy connection of round or flat conductors with the reinforcement.

Specification	Fit		PU	Ord. no.
	Reinforcement	Conductor		
Steel, bare	ø 10 - 20 mm	fl. 30 / 40 mm	25	111 690
Steel, bare	ø 20 - 40 mm	fl. 30 / 40 mm	25	111 691
Steel, bare	ø 10 - 20 mm	ø 10 mm and/or fl. 30 / 40 mm	25	111 692
Steel, bare	ø 20 - 40 mm	ø 10 mm and/or fl. 30 / 40 mm	25	111 693
Steel, hot galvanized	ø 10 - 20 mm	fl. 30 / 40 mm	25	111 694
Steel, hot galvanized	ø 20 - 40 mm	fl. 30 / 40 mm	25	111 695
Steel, hot galvanized	ø 10 - 20 mm	ø 10 mm and/or fl. 30 / 40 mm	25	111 696
Steel, hot galvanized	ø 20 - 40 mm	ø 10 mm and/or fl. 30 / 40 mm	25	111 697

## Connecting clamp for reinforcement



Ord. no. 111 690



Ord. no. 111 696



## Reinforcement terminal clamps

### Benefits:

- No loose components during installation.
- Low construction height after installation.
- All existing connection types such as T-, cross-, parallel- and diagonal- connections are possible.
- Various diameters are possible e.g. flat 30x3.5 mm and  $\varnothing$  5 - 25 mm.
- Only one screw M10 = central contact pressure.
- Optimal economic use for planning, stockkeeping, calculation and accounting.

### Multi-flat+round terminal clamp



Ord. no. 111 796



Ord. no. 111 799

### Multi-flat+round terminal clamp (fl. 30 x 3.5 / $\varnothing$ 5 - 25 mm)

for a fast and easy connection of flat conductor with reinforcement.

Specification	Fit		PU	Ord. no.
	Reinforcement	Conductor		
Steel, bare	$\varnothing$ 5 - 25 mm	fl. 30 x 3.5 mm	25	111 796
Steel, hot galvanized	$\varnothing$ 5 - 25 mm	fl. 30 x 3.5 mm	25	111 797
Steel, bare with double terminal clamp $\varnothing$ 8-10 mm	$\varnothing$ 5 - 25 mm	fl. 30 x 3.5 mm $\varnothing$ 10 mm	25	111 798
Steel, hot galvanized with double terminal clamp $\varnothing$ 8-10 mm	$\varnothing$ 5 - 25 mm	fl. 30 x 3.5 mm $\varnothing$ 10 mm	25	111 799

Specification in **stainless steel** on request.

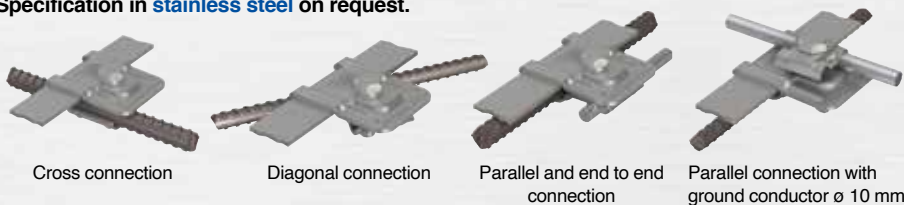

Cross connection

Diagonal connection

Parallel and end to end connection

Parallel connection with ground conductor  $\varnothing$  10 mm

Multi-flat+round terminal clamp – now also available with countersunk screw and carriage bolt.  
For a quick and easy connection of flat conductor with the reinforcement.

### Other benefits:

#### Benefit of a countersunk screw with hexagon socket:

- Extremely low construction height for low concrete coverage.

#### Benefit of a carriage bolt:

- Faster component installation.

#### Benefit of a turned carriage bolt:

- Installation of flat conductor underneath reinforcement is possible.

### Multi-flat+round terminal clamp



Ord. no. 111 800



Ord. no. 111 802



Ord. no. 111 804

### Multi-flat+round terminal clamp (fl. 30 x 3.5 / $\varnothing$ 5 - 16 mm)

for a quick and easy connection of flat conductor with reinforcement.

Specification <b>countersunk screw with internal hexagon</b>	Fit		PU	Ord. no.
	Reinforcement	Conductor		
Steel, bare	$\varnothing$ 5 - 16 mm	fl. 30 x 3.5 mm	25	111 800

### Multi-flat+round terminal clamp (fl. 30 x 3.5 / $\varnothing$ 5 - 16 mm)

For a quick and easy connection of flat conductor with reinforcement.

Specification with <b>carriage bolt</b>	Fit		PU	Ord. no.
	Reinforcement	Conductor		
Steel, bare (hexagonal nut on the side of the flat conductor)	$\varnothing$ 5 - 16 mm	fl. 30 x 3.5 mm	25	111 802
Steel, bare (hexagonal nut on the reinforcement side)	$\varnothing$ 5 - 16 mm	fl. 30 x 3.5 mm	25	111 804



## Multi-Max reinforcement clamp 50x50 mm

### Benefits:

- No loose components during installation.
- Only one screw M10 = central contact pressure.
- All existing connection types such as T-, cross- and parallel-connection are possible.
- Suitable for conductors flat 30 x 3.5 mm or Ø 10 mm.
- Low construction height.

### Multi-Max reinforcement clamp 50x50 mm

Specification with hexagon bolt	Fit		PU	Ord. no.
	Reinforcement	Conductor		
Steel, bare	ø 4-16 mm	fl. 30 x 3.5 mm or ø 10 mm	50	111 806
Steel, hot galvanized	ø 4-16 mm	fl. 30 x 3.5 mm or ø 10 mm	50	111 816

### Benefit of a carriage bolt:

- Faster component installation.

### Benefit of a turned carriage screw:

- Installation of conductor underneath reinforcement is possible.

Specification with carriage bolt	Reinforcement	Conductor	PU	Ord. no.
Steel, bare (hexagonal nut on the side of the ground strap)	ø 4-16 mm	fl. 30 x 3.5 mm or ø 10 mm	50	111 807
Steel, hot galvanized (hexagonal nut on the side of the ground strap)	ø 4-16 mm	fl. 30 x 3.5 mm or ø 10 mm	50	111 817
Steel, bare (hexagonal nut on the armour side)	ø 4-16 mm	fl. 30 x 3.5 mm or ø 10 mm	50	111 809
Steel, hot galvanized (hexagonal nut on the armour side)	ø 4-16 mm	fl. 30 x 3.5 mm or ø 10 mm	50	111 819

### Benefit of a threaded bolt:

- Assembly possible in two steps:
  1. Connect the foundation earth electrode (round) to the reinforcement
  2. Connect and fix the fixed earthing terminal to the reinforcement

Specification with threaded bolt	Reinforcement	Conductor	PU	Ord. no.
Steel, bare with threaded bolt M10 x 20	ø 4-16 mm	fl. 30 x 3.5 mm or ø 10 mm	50	111 808
Steel, hot galvanized with threaded bolt M10 x 60	ø 4-16 mm	fl. 30 x 3.5 mm or ø 10 mm	50	111 818

## Multi-Max reinforcement clamp 75x75 mm

### Benefits:

- No loose components during installation.
- Only one screw M12 = central contact pressure.
- All existing connection types such as T-, cross- and parallel-connection are possible.
- Various diameters from ø 8 mm to ø 32 mm are possible.

### Multi-Max reinforcement clamp 75x75 mm

Specification	Fit		PU	Ord. no.
	Upper part	Bottom part		
Steel, bare with hexagon bolt	ø 8-16 mm / ø 15-32 mm	ø 8-16 mm / ø 15-27 mm	10	111 810
Steel, hot galvanized with hexagon bolt	ø 8-16 mm / ø 15-32 mm	ø 8-16 mm / ø 15-27 mm	10	111 820

## Multi-Max reinforcement clamp

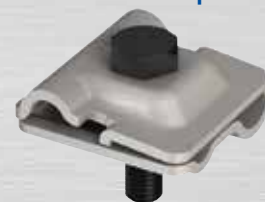

Ord. no. 111 806



Ord. no. 111 807



Ord. no. 111 809



Ord. no. 111 808

Example of application:

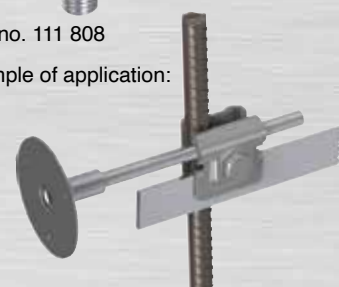

## Multi-Max reinforcement clamp



Ord. no. 111 810



## Smart connector



Ord. no. 111 417



Ord. no. 111 408

Smart connector, to connect reinforcement and round conductors with clamping screw M10.

Specification	Fit		PU	Ord. no.
	Reinforcement	Conductor		
Steel, bare	ø 6-16 mm	ø 10 mm	50	111 416
Steel, hot galvanized	ø 6-16 mm	ø 10 mm	50	111 417
Specification	Fit		PU	Ord. no.
Reinforcement	Conductor			
Steel, bare	ø 6-10 mm	ø 10 mm	100	111 406
Steel, hot galvanized	ø 6-10 mm	ø 10 mm	100	111 407
<b>Stainless steel V2A</b>	ø 6-10 mm	ø 10 mm	100	<b>111 408</b>
<b>Stainless steel V4A</b>	ø 6-10 mm	ø 10 mm	100	<b>111 409</b>



Cross clamp  
ø 10 / ø 16 mm



Cross clamp  
ø 6-10 / ø 10 mm



Parallel clamp  
ø 10 / ø 10 mm



End to end connector  
ø 10 / ø 10 mm

Only possible with ord. no. 111 406 - 111 409

## Connecting clamp small type



Ord. no. 111 414

Application example:



### Benefits:

- Cost-efficient solution for connections of flat conductor with small reinforcement steel.
- Compact design.
- Only one screw M10.

Connecting clamp small type for different combinations, with clamp screw M10.

Specification	Fit (flat / flat or flat / round)		PU	Ord. no.
	fl. 30 x 3.5 mm	fl. 30 x 3.5 mm or ø 6 - 12 mm		
Steel, bare	fl. 30 x 3.5 mm	fl. 30 x 3.5 mm or ø 6 - 12 mm	25	111 413
Steel, hot galvanized	fl. 30 x 3.5 mm	fl. 30 x 3.5 mm or ø 6 - 12 mm	25	111 414

## Connecting clamp fl. 40 mm



Ord. no. 111 841



Ord. no. 111 843



Magnetic mounting aid (Ord. no. 110 241) at page 175.

Connecting clamp fl. 40 mm for different combinations.

Specification	Fit (flat / flat or flat / round)		PU	Ord. no.
	fl. 40 mm	fl. 40 mm or ø 6 - 16 mm		
<b>with clamping bracket and spring</b>				
Steel, bare	fl. 40 mm	fl. 40 mm or ø 6 - 16 mm	25	111 842
Steel, hot galvanized	fl. 40 mm	fl. 40 mm or ø 6 - 16 mm	25	111 843
<b>without clamping bracket</b>				
Steel, bare	fl. 40 mm	fl. 40 mm or ø 6 - 16 mm	25	111 840
Steel, hot galvanized	fl. 40 mm	fl. 40 mm or ø 6 - 16 mm	25	111 841

Example of application:



## Connecting clamp

**Connecting clamp** for different combinations,  
 $\varnothing$  6 - 20 mm and flat 30 x 3.5 mm or  $\varnothing$  10 mm; with clamping screw M10.

Specification	Reinforcement	Fit	PU	Ord. no.
		Conductor (flat or round)		
<b>with clamping bracket</b>				
Steel, hot galvanized	$\varnothing$ 6 - 20 mm	fl. 30x3.5 mm or $\varnothing$ 10 mm	25	111 424
Steel, bare	$\varnothing$ 6 - 20 mm	fl. 30x3.5 mm or $\varnothing$ 10 mm	25	111 423
Stainless steel V2A	$\varnothing$ 6 - 20 mm	fl. 30x3.5 mm or $\varnothing$ 10 mm	25	111 424 S1
<b>*without clamping bracket</b>				
Steel, hot galvanized	$\varnothing$ 6 - 20 mm	fl. 30x3.5mm	25	111 424 S
Steel, bare	$\varnothing$ 6 - 20 mm	fl. 30x3.5mm	25	111 423 S
Stainless steel V2A	$\varnothing$ 6 - 20 mm	fl. 30x3.5mm	25	111 424 S2

Specification	Reinforcement	Fit	PU	Ord. no.
		Conductor		
<b>with clamping bracket</b>				
Steel, hot galvanized	$\varnothing$ 6 - 25 mm	fl. 30/40 mm or $\varnothing$ 10 mm	25	111 421 S2
Steel, bare	$\varnothing$ 6 - 25 mm	fl. 30/40 mm or $\varnothing$ 10 mm	25	111 420 S2
<b>*without clamping bracket</b>				
Steel, hot galvanized	$\varnothing$ 10 - 29 mm	fl. 30/40 mm	25	111 421
Steel, bare	$\varnothing$ 10 - 29 mm	fl. 30/40 mm	25	111 420

$\varnothing$  10 / fl. 30 x 3.5 mm     $\varnothing$  16 /  $\varnothing$  10 mm     $\varnothing$  16 / fl. 30 x 3.5 mm    fl. 30 x 3.5 / fl. 30 x 3.5 mm     $\varnothing$  20 / fl. 30 x 3.5 mm

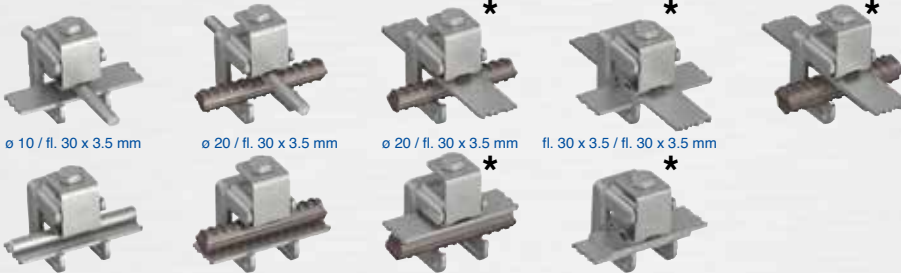

\* Connection without clamping bracket also possible

## Connecting clamp with bracket and spring

for different combinations; with one clamping screw M10.

Specification	Reinforcement	Fit	PU	Ord. no.
		Conductor		
Steel, bare	$\varnothing$ 6 - 25 mm	fl. 30/40 mm or $\varnothing$ 10 mm	25	111 330
Steel, hot galvanized	$\varnothing$ 6 - 25 mm	fl. 30/40 mm or $\varnothing$ 10 mm	25	111 331
<b>Specification</b>				
Specification	Reinforcement	Fit	PU	Ord. no.
		Conductor		
Steel, bare	$\varnothing$ 6 - 20 mm	fl. 30x3.5 mm or $\varnothing$ 10 mm	25	111 333
Steel, hot galvanized	$\varnothing$ 6 - 20 mm	fl. 30x3.5 mm or $\varnothing$ 10 mm	25	111 334
Stainless steel V2A	$\varnothing$ 6 - 20 mm	fl. 30x3.5 mm or $\varnothing$ 10 mm	25	111 332

## Connecting clamp max

**Connecting clamp max** for different combinations,  
with one clamping screw M10.

Specification	Reinforcement	Fit	PU	Ord. no.
		Conductor (flat or round)		
<b>with clamping bracket and spring</b>				
Steel, hot galvanized	$\varnothing$ 25 - 38 mm	fl. 30 mm / fl. 40 mm or $\varnothing$ 10 mm	25	111 839
Steel, bare	$\varnothing$ 25 - 38 mm	fl. 30 mm / fl. 40 mm or $\varnothing$ 10 mm	25	111 838
<b>without clamping bracket</b>				
Steel, hot galvanized	$\varnothing$ 25 - 38 mm	fl. 30 mm or fl. 40 mm	25	111 837
Steel, bare	$\varnothing$ 25 - 38 mm	fl. 30 mm or fl. 40 mm	25	111 836

## Connecting clamp

( utility patent)



Ord. no. 111 424

Ord. no. 111 424 S

Ord. no. 111 421 S2

Ord. no. 111 420

## Connecting clamp with spring

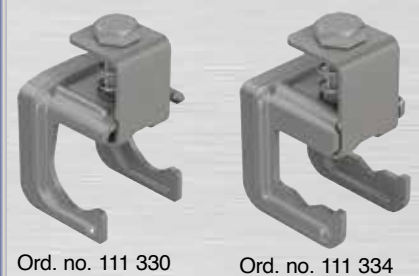

Ord. no. 111 330

Ord. no. 111 334

## Connecting clamp max



Application example:  
of Ord. no. 111 837

Ord. no. 111 839



## Cross connector two-part and three-part



Ord. no. 1322



Ord. no. 1329

## Wedge connector



Ord. no. 1320



Ord. no. 1320 S

## ES-clamp



Ord. no. 111 698

## Cross connector, two-part and three-part.

Specification		Fit	PU	Ord. no.
Steel, hot galvanized	two-part	round/flat	25	1322
Steel, hot galvanized		round/round	25	1329
Steel, hot galvanized		flat/flat	25	1323
Steel, hot galvanized		flat/flat	25	900 047
Steel, hot galvanized		round/flat	25	910 007
Steel, hot galvanized		round/round	25	1324
Steel, hot galvanized	three-part	round/flat	25	1325
Steel, hot galvanized		flat/flat	25	1326
Steel, hot galvanized		round/round	25	1327 S
Steel, hot galvanized		round/round	25	1327
<b>Stainless steel V2A</b>	two-part	flat/flat	25	<b>2004</b>
<b>Stainless steel V2A</b>		round/flat	25	<b>2003</b>
<b>Stainless steel V2A</b>		round/round	25	<b>2005 S</b>
<b>Stainless steel V2A</b>		round/round	25	<b>2005</b>
<b>Stainless steel V4A</b>	two-part	flat/flat	25	<b>910 494</b>
<b>Stainless steel V4A</b>		round/flat	25	<b>910 259</b>
<b>Stainless steel V4A</b>		round/round	25	<b>910 260</b>

## Wedge connector with safety catch, for T-, cross- and parallel- connections Installation: Wedge has to be installed crosswise to the conductor!

Specification	Fit	PU	Ord. no.
Steel, electro-galvanized	ø 10/fl. 30 mm or fl. 30/fl. 30 mm	40	1320
Steel, electro-galvanized with hexagonal screw	ø 10/fl. 30 mm or fl. 30/fl. 30 mm	40	1320 S

Example of applications:



fl. 30 mm / fl. 30 mm  
Cross clamp



fl. 30 mm / fl. 30 mm  
Parallel clamp



ø 10 mm / fl. 30 mm  
Cross clamp

## ES-reinforcement clamp, for connection of flat and round conductors to reinforcement steel.

Specification	Reinforcement	Fit		PU	Ord. no.
		Conductor			
Steel, bare	ø 10 - 40 mm	ø 10 / fl. 30 - 40 mm		25	111 698
Steel, hot galvanized	ø 10 - 40 mm	ø 10 / fl. 30 - 40 mm		25	111 699



fl. 30 x 3.5 / ø 12 mm



ø 10 / ø 28 mm



ø 10 / ø 28 mm



fl. 30 x 3.5 / ø 28 mm

## Earth rods

Earth rod Modular plugable according to EN 62561-2.

Specification	Corresponding driving steel darts	Fit	PU	Ord. no.
<b>Earth rod:</b>				
Type A, steel, hot galvanized with 3-fold knurling	2058	ø 20/1500 mm	6	110 020
	2058	ø 20/1000 mm	6	110 029
	2059	ø 25/1500 mm	5	110 027
	2059	ø 25/1000 mm	5	110 019
Type A, stainless steel V2A	2058	ø 20/1500 mm	6	110 120
	2058	ø 20/1000 mm	6	910 095
Type A, stainless steel V4A	2058	ø 20/1500 mm	6	110 121
	2058	ø 20/1000 mm	6	110 122
Type BP, Steel, hot galvanized with lead ball	2059	ø 25/1000 mm	5	110 024
<b>Tubular earth rod:</b>				
Type C, steel, hot galvanized	2058	ø 25/1500 mm	10	110 021
Type C, stainless steel V2A	2059	ø 25/1500 mm	10	110 026
Type C, stainless steel V4A	2059	ø 25/1500 mm	10	110 018

Driving steel darts, suitable for earth rods.

Specification	Fit	PU	Ord. no.
Driving steel darts for ER ø 20 mm <b>Type A</b> ø 25 mm <b>Type C</b> St/hot galvanized (Ord. no. 110 021)	Steel, electro galvanized	1	2058
Driving steel darts for ER ø 25 mm <b>Type A</b> / <b>Type BP</b> / <b>Type C stainless steel</b> (Ord. no. 110 018; 110 026)	Steel, electro galvanized	1	2059

Connection clamp with 2 screws M10 suitable for parallel- and cross- connections.

Specification	Fit	PU	Ord. no.
Steel, hot galvanized	three-part ø 8-10 & fl. 30-40/ ø 16 mm	25	111 355
Steel, hot galvanized	ø 8-10 & fl. 30-40/ ø 20 mm	25	111 356
Steel, hot galvanized	ø 8-10 & fl. 30-40/ ø 25 mm	25	111 357
Stainless steel V2A	two-part ø 10 & fl. 30-40/ ø 16 mm	25	2009
Stainless steel V2A	ø 10 & fl. 30-40/ ø 20 mm	25	2010
Stainless steel V2A	ø 10 & fl. 30-40/ ø 25 mm	25	2011
Stainless steel V4A	two-part ø 10 & fl. 30-40/ ø 16 mm	25	2013
Stainless steel V4A	ø 10 & fl. 30-40/ ø 20 mm	25	2017
Stainless steel V4A	ø 10 & fl. 30-40/ ø 25 mm	25	2031

Connection clamp, suitable for earth rod and ø 10 mm round conductors.

Specification	Fit	PU	Ord. no.
Steel, hot galvanized	ø 8-10 & ER ø 20 mm	50	2020
Stainless steel V4A	ø 8-10 & ER ø 20 mm	50	2018
Steel, hot galvanized	flat 30x3.5 mm; ø 10 & ER ø 25 mm	25	2021
Stainless steel V4A	flat 30x3.5 mm; ø 10 & ER ø 25 mm	25	2025

TE-Smart connector, with one screw M10 for cross connection. Installation-friendly mount function - no threading necessary.

Specification	Fit		PU	Ord. no.
	Conductor	Earth rod		
Edelstahl V2A	ø 10 mm or fl. 30 mm	ø 20 mm or ø 25 mm	25	111 822
Edelstahl V4A	ø 10 mm or fl. 30 mm	ø 20 mm or ø 25 mm	25	111 824

## Earth rod and tubular earth rod

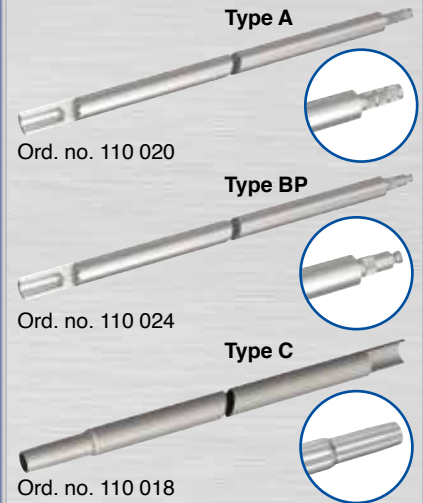

## Driving steel darts

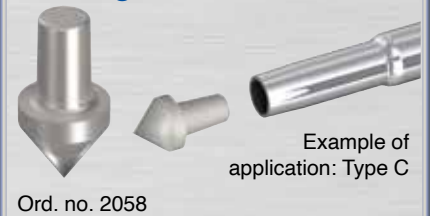

## Connection clamp for earth rod and earth lead-in rod



## Connection clamp for earth rod





## Earth rod driver



Ord. no. 111 461    Ord. no. 111 460

## Driving heads



Ord. no. 2056

## Adapters



Ord. no. 111 478 S



Ord. no. 111 466

## Earth rod driver

Specification		PU	Ord. no.
<b>Brand:</b>	<b>Hikoki</b>	1	111 460
Type:	H 90 SG electric motor		
Power:	2000 Watt		
Single stroke energy:	70 Joule		
Weight:	32 kg	1	111 461
<b>Brand:</b>	<b>WACKER</b>		
Type:	BH 55 gasoline motor		
Single stroke energy:	55 Joule		
Weight:	24 kg		

## Driving heads suitable for earth rods and tubular earth rods.

Specification		Fit	PU	Ord. no.
Driving head for	ER Type A (ø 20 mm)	ø 20 mm	1	2056
Driving head for	ER Type A, Type BP (ø 25 mm)	ø 25 mm	1	2057
Driving head for	ER Type C (tubular earth rod)	ø 25 mm	1	111 458

## Adapters

for earth rod driver, suitable for earth rods and tubular earth rods.

Manufacturer	Type	Earth rod Type A ø 20 mm	Earth rod Type A, Type BP ø 25 mm	Tubular earth rod Type C ø 25 mm
		Ord. no.	Ord. no.	Ord. no.
Bosch	GSH 16-28; USH 27; GSH 27 VC; HSH 28	111 479	111 479 S1	111 479 S
Hikoki/ Hitachi	H65; H65SD2; H65SD3; H70SD; H70SD3; H90SG; H90SE	111 463 S	111 464 S	111 465 S
Hilti	TE 3000-AVR			
Wacker	BH55 Wacker -number: 5100004026 BH65 Wacker number: 5100004032	111 466	111 467	111 468
Bosch Makita	GSH 16-30 HM1317C; HM1400; HM1300; HM1801; HM1500	111 478 S	111 478 S1	111 478
all SDS-Max adapters		111 576	111 577	111 578

Additional adapters on request.

## Expansion piece



Ord. no. 111 445

## Expansion piece

as bridging component for expansion joints of foundation earth electrode.

Specification		Fit	PU	Ord. no.
<b>Strip</b>	<b>Block</b>			
Stainless steel V2A	polystyrene	30 x 3.5 mm	1	111 445
Stainless steel V4A	polystyrene	40 x 4 mm	1	111 445 S

Example of application:

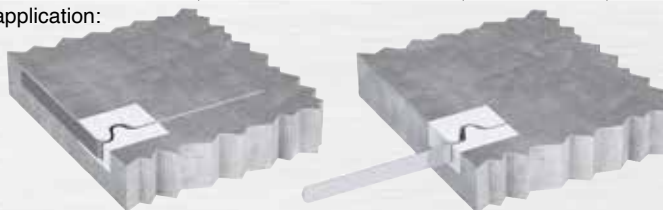

## Expansion strip



Ord. no. 111 448

## Expansion strip, for a connection of the foundation earth electrode outside the concrete.

Specification	Length	Fit	PU	Ord. no.
Aluminium	250 mm	40 x 5.0 mm	1	111 448

Additional lengths on request!





**Earthing pipe clamp** for antenna standpipes. For pipe diameters from ca. 3/4"- 6", for cross-section of connecting conductor from 10 mm<sup>2</sup> (ø 4 mm) to up to 50 mm<sup>2</sup> (ø 8 mm).

Specification	Fit	Fit in inch	PU	Ord. no.
Stainless steel V2A	ø 25 - 88.9 mm	3/4" - 3"	25	111 390
	ø 25 - 168 mm	3/4" - 6"	25	111 391
Steel, hot galvanized	ø 25 - 88.9 mm	3/4" - 3"	25	111 393
	ø 25 - 168 mm	3/4" - 6"	25	111 394

**Earthing pipe clamp** for steel and copper pipes from ø 17 mm up to ø 115 mm, for cross section of connecting conductors from 4 mm<sup>2</sup> (ø 2.3 mm) up to 50 mm<sup>2</sup> (ø 8 mm).

Specification	Fit	Fit in inch	PU	Ord. no.
Stainless steel V2A	ø 17 - 50 mm	3/8" - 1 1/2"	25	111 441
Stainless steel V2A	ø 17 - 115 mm	3/8" - 4"	25	111 442

**Turnbuckle** without strip for antenna standpipes for cross section of connecting conductors from 10 mm<sup>2</sup> (ø 4 mm) up to 50 mm<sup>2</sup> (ø 8 mm).

Specification	PU	Ord. no.
Stainless steel V2A	50	111 392
Steel, hot galvanized	50	111 395

**Insulated rod holder with turnbuckle** without strap

Ausführung	Fit	PU	Ord. no.
NEW! Stainless steel V2A / PVC	ø 16 mm	50	111 896
NEW! Stainless steel V2A / PVC	ø 8-10 mm	50	111 897
NEW! Stainless steel V2A / PVC	fl. 30 mm	50	111 898

**Turnbuckle** without strip for cross section of connecting conductors from 4 mm<sup>2</sup> (ø 2.3 mm) up to 50 mm<sup>2</sup> (ø 8 mm).

Specification	PU	Ord. no.
Stainless steel V2A	100	111 449

**Stainless steel - tensioning strap 22 x 0.4 mm** in a practical box for individual cutting to lengths or **pre-assembled**; suitable for mentioned turnbuckles.

Specification	Length	PU	Ord. no.
Strap stainless steel V2A	25 m	1	913 825
Strap stainless steel V2A	50 m	1	913 831

Specification	Fit	Fit in inch	PU	Ord. no.
NEW! Strap stainless steel V2A	ø 25 - 88.9 mm	up to 3"	50	111 893
NEW! Strap stainless steel V2A	ø 25 - 168 mm	up to 6"	50	111 894

**Earthing pipe clamp** for steel and copper pipes between ø 9.7 - 114.3 mm, for protective conductor connecting from 2.5 mm<sup>2</sup> up to 16 mm<sup>2</sup>.

Specification	Fit	Fit in inch	PU	Ord. no.
Turnbuckle steel, hot galvanized,	ø 9.7 - 48.3 mm	1/8" - 1 1/2"	25	111 260
Strap bronze/nickel-plated	ø 9.7 - 114.3 mm	1/8" - 4"	25	111 440

## Earthing pipe clamp for antenna standpipes



Ord. no. 111 390

## Earthing pipe clamp



Ord. no. 111 442

## Turnbuckle



Ord. no. 111 392

Ord. no. 111 897

Ord. no. 111 449

## Tensioning strap



Ord. no. 913 825

Ord. no. 111 893

## Earthing pipe clamp



Ord. no. 111 260



## Earthing pipe clamp



Ord. no. 111 650

## Earthing pipe clamp



Ord. no. 111 261

## Earthing pipe clamp



Ord. no. 1244

**Earthing pipe clamp** for earthing connections with cross section of 6 - 50 mm<sup>2</sup>, lengthwise and crosswise, for equipotential bonding.

Specification	Fit	Fit in inch	PU	Ord. no.
Steel, hot galvanized	ø 13.5 - 17.2 mm	1/4" - 3/8"	100	111 650
Steel, hot galvanized	ø 21.3 - 26.9 mm	1/2" - 3/4"	25	111 651
Steel, hot galvanized	ø 33.7 mm	1"	50	111 652
Steel, hot galvanized	ø 42.4 - 48.3 mm	1 1/4" - 1 1/2"	50	111 653

**Earthing pipe clamp** for connecting conductors with cross section of 35 - 50 mm<sup>2</sup>.

Specification	Fit	Fit in inch	PU	Ord. no.
Copper/galvanized Sn	ø 21.3 - 26.9 mm	1/2" - 3/4"	75	111 261
Copper/galvanized Sn	ø 25 - 36 mm	ca. 3/4" - 1"	50	298 900

**Earthing pipe clamp** for pipes, made of Stainless steel V2A or steel, according to EN 62561-1.

Specification	Fit	Fit in inch	PU	Ord. no.
Steel, hot galvanized	ø 17.2 mm	3/8"	25	1240
Steel, hot galvanized	ø 21.3 mm	1/2"	25	1241
Steel, hot galvanized	ø 26.9 mm	3/4"	25	1242
Steel, hot galvanized	ø 33.7 mm	1"	25	1243
Steel, hot galvanized	ø 42.4 mm	1 1/4"	25	1244
Steel, hot galvanized	ø 48.3 mm	1 1/2"	25	1245
Steel, hot galvanized	ø 54.5 mm	1 3/4"	25	1249
Steel, hot galvanized	ø 60.3 mm	2"	25	1246
Steel, hot galvanized	ø 76.1 mm	2 1/2"	25	1247
Steel, hot galvanized	ø 88.9 mm	3"	25	1248
Steel, hot galvanized	ø 114.3 mm	4"	25	910 286

Stainless steel V2A	ø 17.2 mm	3/8"	25	111 240
Stainless steel V2A	ø 21.3 mm	1/2"	25	111 241
Stainless steel V2A	ø 26.9 mm	3/4"	25	111 242
Stainless steel V2A	ø 33.7 mm	1"	25	111 243
Stainless steel V2A	ø 42.4 mm	1 1/4"	25	111 244
Stainless steel V2A	ø 48.3 mm	1 1/2"	25	111 245
Stainless steel V2A	ø 54.5 mm	1 3/4"	25	111 249
Stainless steel V2A	ø 60.3 mm	2"	25	111 246
Stainless steel V2A	ø 76.1 mm	2 1/2"	25	111 247
Stainless steel V2A	ø 88.9 mm	3"	25	111 248
Stainless steel V2A	ø 114.3 mm	4"	25	910 572

Earthing pipe clamp also available in **copper**.

## KS-Connector



Ord. no. 1360

Ord. no. 1359

Ord. no. 1464

## KS-Connector

Clamping screw with hexagonal nut M10 suitable for round conductor ø 6-10 mm.

Specification	Fit	PU	Ord. no.
Steel, hot galvanized / aluminium clamping ring	ø 6-10 mm	100	1360
Stainless steel V2A coppered	ø 6-10 mm	100	1361
Stainless steel V2A	ø 6-10 mm	100	1362
Stainless steel V4A	ø 6-10 mm	100	1464
Steel, hot galvanized with square clamping bracket	ø 8-10 mm	100	1359

## Multi-clamping jaw



Ord. no. 1270 S3

122

## Multi-clamping jaw,

suitable for round conductor up to ø 10 mm, with carriage bolt M10 and nut.

Specification	Fit	PU	Ord. no.
Steel, hot galvanized	ø 8 - 10 mm	100	1270 S3
Aluminium	ø 8 mm	100	1271 S
Stainless steel V2A	ø 8 - 10 mm	100	1273 S1

## Fixed earthing terminals and connection sets

A complete range for connecting equipotential bonding conductors to the foundation earth electrode, to the reinforcement and to the lightning protection system.

- Benefits:**
- Easy assembly due to flexible connections.
  - Corrosion-resistant, reliable connections due to stainless steel contacts.
  - Also suitable as test joint.

### Fixed earthing terminal,

for the connection of earth termination systems, reinforcement and down conductors.

Specification	Screw-sets (page 127) optional		Ord. no.
	connection thread	set-no.	
Completely made of stainless steel			
Contact plate ø 80 mm <b>stainless steel V4A</b> with 3 mounting holes ø 4 mm; with plastic cover with terminal stud ø 10 mm; total length 190 mm	M12	set 03	112 000
Equal to ord. no. 112 000, but with foam cover	M10	set 02	
	M12	set 03	112 200
	M10	set 02	
Made of stainless steel / steel			
Contact plate ø 80 mm <b>stainless steel V4A</b> with 3 mounting holes ø 4 mm; threaded sleeve ø 16 mm; <b>with terminal stud ø 10 mm steel</b> , total length 190 mm; with foam cover	M12	set 03	112 150
Equal to ord. no. 112 150, but with threaded sleeve ø 20 mm <b>and terminal stud ø 12 mm steel</b>	M10	set 02	
	M12	set 03	112 151
	M10	set 02	
Equal to ord. no. 112 150, but with threaded sleeve ø 20 mm <b>and terminal stud ø 10 mm steel</b>	M12	set 03	112 152
	M10	set 02	
Contact plate ø 80 mm <b>stainless steel V4A</b> with 3 mounting holes ø 4 mm; threaded sleeve ø 25 mm; <b>with terminal stud ø 12 mm steel</b> , total length 190 mm; with foam cover	M16	set 06	112 153

### Fixed earthing terminal,

for the connection of earth termination systems, reinforcement and down conductors.

Specification	Screw-sets (page 127) optional		Ord. no.
	connection thread	set-no.	
Contact plate ø 80 mm <b>stainless steel V4A</b> with 3 mounting holes ø 4 mm with plastic cover	M10	set 01	112 007
Equal to ord. no. 112 007	M12	set 03	112 004
Equal to ord. no. 112 007, but with foam cover	M10	set 01	112 207
Equal to ord. no. 112 004, but with foam cover	M12	set 03	112 204

Connection cable with cable lug on request!

### Fixed earthing terminal M16 for flexible connection 70 mm<sup>2</sup>,

for the connection of earth termination systems, reinforcement and down conductors.

Specification	Screw-sets (page 127) optional		Ord. no.
	connection thread	set-no.	
Contact plate ø 80 mm <b>stainless steel V4A</b> with 3 mounting holes ø 4 mm. and connection part 70 mm <sup>2</sup> Cu/Sn 400 mm long	M16	set 05	112 155

Note:

The value for  $I_k$  = short circuit current (50Hz)(1s; ≤ 300°C) can be found in the index directory starting from page 199.

### Fixed earthing terminal with terminal stud

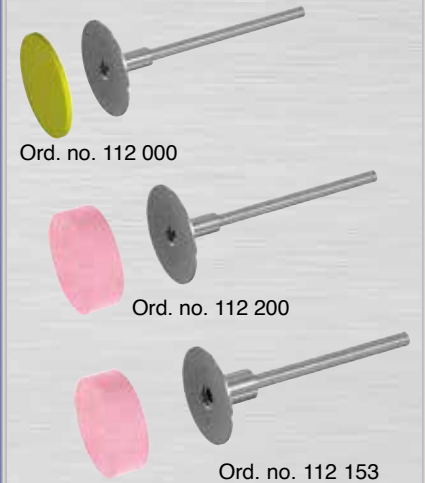

### Fixed earthing terminal for flexible connection

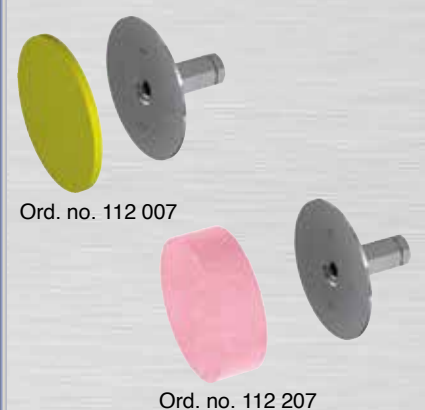

### Fixed earthing terminal for flexible connection





## Fixed earthing terminal with welded cross clamp



Ord. no. 112 008



Ord. no. 112 154

## Fixed earthing terminal with red plastic ring



Ord. no. 112 020

## Fixed earthing terminal for flexible connection



Ord. no. 112 022

## Fixed earthing terminal with welded cross clamp



Ord. no. 112 024

## Fixed earthing terminal,

for the connection of earth termination systems, reinforcement and down conductors.

Specification	Screw-sets (page 127) optional		Ord. no.
	connection thread	set-no.	
Contact plate ø 80 mm <b>stainless steel V4A</b> with 3 mounting holes ø 4 mm; with terminal stud and cross clamp for flat 30 mm/ø 8-10 mm with plastic cover	M10	set 01	112 008
Equal to ord. no. 112 008,	M12	set 03	112 002
Equal to ord. no. 112 008, but with foam cover	M10	set 01	112 208
Equal to ord. no. 112 002, but with foam cover	M12	set 03	112 202
Contact plate ø 80 mm <b>stainless steel V4A</b> with 3 mounting holes ø 4 mm; with terminal stud and adjustable cross clamp for flat 40 mm/ø 8-10 mm	M16	set 06	112 154
	M12	set 04	

## Fixed earthing terminal,

for the connection of earth termination systems, reinforcement and down conductors.

Specification	Screw-sets (page 127) optional		Ord. no.
	connection thread	set-no.	
Contact plate ø 50 mm <b>stainless steel V4A</b> Red plastic ring, ø 95 mm with 3 mounting holes ø 3.4 mm; with clamping pin ø 10 mm, total length 200 mm with plastic cover	M10	set 01	112 020
Equal to ord. no. 112 020,	M12	set 03	112 021

Connection with diagonal cross clamp possible, see page 112!

## Fixed earthing terminal,

for the connection of earth termination systems, reinforcement and down conductors.

Specification	Screw-sets (page 127) optional		Ord. no.
	connection thread	set-no.	
Contact plate ø 50 mm <b>stainless steel V4A</b> Red plastic ring, ø 95 mm with 3 mounting holes ø 3.4 mm; for connection with cable lug or steel strip	M10	set 01	112 022
Equal to ord. no. 112 022,	M12	set 03	112 023

Connection cable with cable lug on request!

## Fixed earthing terminal,

for the connection of earth termination systems, reinforcement and down conductors.

Specification	Screw-sets (page 127) optional		Ord. no.
	connection thread	set-no.	
Contact plate ø 50 mm <b>stainless steel V4A</b> Red plastic ring, ø 95 mm with 3 mounting holes ø 3.4 mm; with connection stud and cross clamp for fl. 30 mm / ø 8-10 mm	M10	set 01	112 024
Equal to ord. no. 112 024,	M12	set 03	112 025

### Note:

Values for  $I_k$  = short circuit current (50Hz)(1s;  $\leq 300^\circ\text{C}$ ) can be found in the index directory starting from page 199 or in our special leaflet "50 Hz Strombelastbarkeit"



## Adjustable wall bushings

### Wall bushing (adjustable) for subsequent

water pressure-tight connection of earthing and equipotential bonding conductors.

Specification	Wall thickness	PU	Ord. no.
<b>Stainless steel V4A</b>	<b>100-200 mm</b>	1	112 010
Thread: M12	180-300 mm	1	112 011
O-Ring-seal on both sides	300-400 mm	1	112 012
Water pressure-tight & corrosion-proof	400-600 mm	1	112 013
Diameter of flange: ø 80 mm			

Connection with, e.g. connection angle ord. no. 112 018.

Specification	Wall thickness	PU	Ord. no.
<b>Stainless steel V4A</b> ; thread: M16	<b>100-200 mm</b>	1	112 156
O-Ring-seal on both sides	180-300 mm	1	112 157
Water pressure-tight & corrosion-proof	300-400 mm	1	112 158
Diameter of flange: ø 80 mm	400-600 mm	1	112 159

Connection with, e.g. connection angle ord. no. 112 046.

### Wall bushing (adjustable) with water barrier,

for water pressure-tight connection of earthing and equipotential bonding conductors for concrete with a high water penetration resistance (e.g. waterproof concrete).

Specification	Setting range	PU	Ord. no.
Connection inside and outside possible.	<b>240 - 290 mm</b>	1	112 113
Contact plate ø 80 mm <b>stainless steel V4A</b>	290 - 340 mm	1	112 114
with 3 mounting holes ø 4 mm.	340 - 390 mm	1	112 115
M12 connection thread, M12 threaded rod			
(use optional screw-set 03)			
with plastic cover			
<b>Cut to individual lengths</b>	<b>200 - 620 mm</b>	1	112 130
<b>Additional wall thicknesses on request</b>			

Specification	Setting range	PU	Ord. no.
Equal to ord. no. 112 113,	<b>240 - 290 mm</b>	1	112 313
but with foam cover	290 - 340 mm	1	112 314
(use optional screw-set 03).	340 - 390 mm	1	112 315
<b>Cut to individual lengths</b>	<b>200 - 620 mm</b>	1	112 330
<b>Additional wall thicknesses on request</b>			

Specification	Setting range	PU	Ord. no.
Equal to ord. no. 112 113,	<b>240 - 290 mm</b>	1	112 160
but with foam cover,	290 - 340 mm	1	112 161
M12 connection thread, M16 threaded rod	340 - 390 mm	1	112 162
(use optional screw-set 03).			
<b>Cut to individual lengths</b>	<b>200 - 620 mm</b>	1	112 167
<b>Additional wall thicknesses on request</b>			

Specification	Setting range	PU	Ord. no.
Equal to ord. no. 112 113,	<b>240 - 290 mm</b>	1	112 170
but with foam cover,	290 - 340 mm	1	112 171
M16 connection thread, M16 threaded rod	340 - 390 mm	1	112 172
(use optional screw-set 06).			
<b>Cut to individual lengths</b>	<b>200 - 620 mm</b>	1	112 177
<b>Additional wall thicknesses on request</b>			

### Wall bushing with fixed length and water barrier,

for the water pressure-tight connection of earthing and equipotential bonding conductors.

Specification	Wall thickness	PU	Ord. no.
Contact plate ø 80 mm <b>stainless steel V4A</b>	<b>101-150 mm</b>	1	112 181
with 3 mounting holes ø 4 mm			
<b>Connecting thread M12</b>			
(use optional screw set 03)			
Connecting bolts ø 25 mm			
<b>Lengths or wall thickness must be specified on ordering.</b>			
<b>Additional wall thicknesses on request</b>			

## Wall bushing



## Wall bushing with water barrier

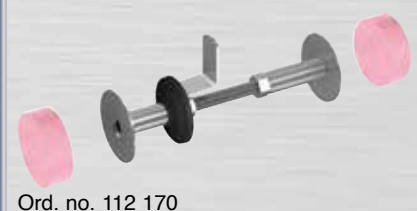
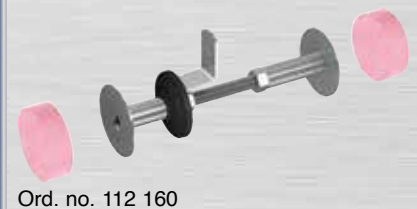
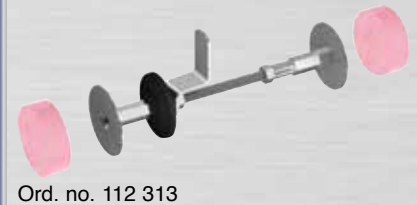
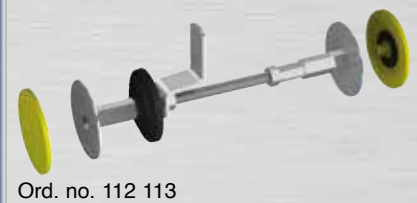

## Wall bushing with fixed length



Earthing material



## Fixed earthing terminal wall bushing



Ord. no. 112 009

## Fixed earthing terminal with water barrier

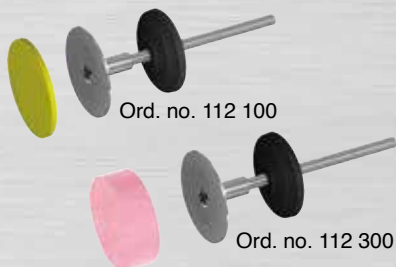

Ord. no. 112 100

Ord. no. 112 300

## Water barrier, for bushings



Ord. no. 112 040

Ord. no. 112 042

**Fixed earthing terminal**, for the connection of earth termination systems to reinforcement and down conductors. **Lengths or wall thickness must be specified on ordering.**

Specification	threaded rod	Screw-sets (page 127) optional		Ord. no.
		connection thread	set-no.	
Interior and exterior connection possible Contact plate $\varnothing$ 80 mm <b>stainless steel V4A</b> with 3 mounting holes $\varnothing$ 4 mm on each plate; up to max. 400 mm (additional lengths on request) with plastic cover	M10	M10	set 01	112 009 
Equal to ord. no. 112 009,	M12	M12	set 03	112 003
Equal to ord. no. 112 009, but with foam cover	M10	M10	set 01	112 209
Equal to ord. no. 112 003, but with foam cover	M12	M12	set 03	112 203

**Fixed earthing terminal with water barrier**, for waterproof concrete, for the connection of earth termination systems, lightning protection and bonding bars.

Specification	Screw-sets (page 127) optional		Ord. no.
	connection thread	set-no.	
Contact plate $\varnothing$ 80 mm <b>stainless steel V4A</b> with 3 mounting holes $\varnothing$ 4 mm with terminal stud $\varnothing$ 10 mm, total length 190 mm	M12	set 03	112 100 
	M10	set 02	
Equal to ord. no. 112 100, but with foam cover	M12	set 03	112 300
	M10	set 02	

**Water barrier for bushings**, for watertight base plates or walls.  
Designed to be pushed onto conductors.

Specification	Fit	PU	Ord. no.
Rubber (TPE-free)	$\varnothing$ 8-10 mm	1	112 040
Rubber (TPE-free)	$\varnothing$ 10-12 mm	1	112 041
Rubber (TPE-free)	flat 30 x 3.5 mm	1	112 042

## Wall bushing for metal facade elements

### Benefits:

- Lightning current carrying capability tested according to EN 62561-1 class H 100 kA (10/350  $\mu$ s).
- Both-sided sealing of drill hole with integrated neoprene sealing rings.
- Economical and practical solution.

## Wall bushing

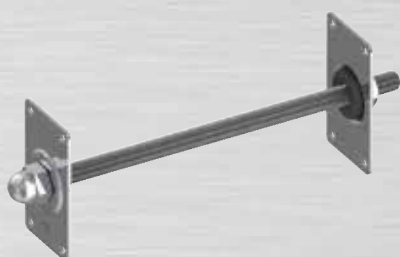

Ord. no. 112 027

Wall bushing for lightning current carrying connection of metal facade elements.

Specification	Element thickness	PU	Ord. no.
<b>Stainless steel V2A</b> Threaded bar M10 Two contact plates 70 x 40 mm with 4 rivet bores $\varnothing$ 5.1 mm and attached neoprene sealing ring. Other element thicknesses on request.	up to 160 mm	1	112 027 



## Accessories for fixed earthing terminals and wall bushings

**Parallel and cross terminal clamp** for connecting fixed earthing terminals.

Specification	Fit	PU	Ord. no.
Steel, hot galvanized	ø 8-10 mm and flat 30 mm ø 10-25 mm	25	111 400
<b>Benefits:</b> Because of two threaded bolts M10x60 mm in the central plate two installation steps are possible: 1. Connect the foundation earth electrode to the reinforcement and 2. Connect and secure the fixed earthing terminal to the earth conductor - parallel and cross possible! Specification with one threaded bolt (e.g. Ord. no. 111 818) look at page 115			

## Parallel and cross terminal clamp



Ord. no. 111 400

Example of application:

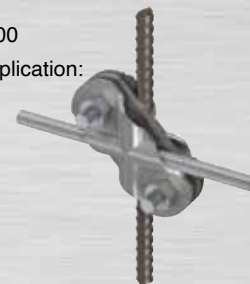

**Cross clamp**, with welded threaded bolt and 4 screws M8 x 25 mm.

Specification	PU	Ord. no.
Cross clamp (60 x 60 mm) steel, hot galvanized for flat 30 mm / ø 8-10 mm; threaded bolt M12 x 25 mm	1	112 005
Cross clamp (60 x 60 mm) <b>stainless steel V4A</b> for flat 30 mm / ø 8-10 mm; threaded bolt M12 x 25 mm	1	112 039
Cross clamp (70 x 70 mm) <b>stainless steel V4A</b> for flat 40 mm / ø 8-10 mm; threaded bolt M16 x 40 mm	1	112 045

Additional specifications on request

## Cross clamp



Ord. no. 112 005

**Screw set**, consisting of a hexagonal screw DIN 933 and a tension washer DIN 6796. Completely made of **stainless steel V4A**.

Set	Specification	PU	Ord. no.
01	Hexagonal screw M10 x 25	1	112 047
02	Hexagonal screw M10 x 40	1	112 049
03	Hexagonal screw M12 x 25	1	112 048
04	Hexagonal screw M12 x 60	1	112 050
05	Hexagonal screw M16 x 25	1	112 051
06	Hexagonal screw M16 x 30	1	112 052

## Screw SET



Ord. no. 112 049

Note: See details for the fixed earthing terminals / wall bushings.

**Connection angle**, for fixed earthing terminals. Completely made of **stainless steel V4A**.

Specification	Bore hole	Height	PU	Ord. no.
<b>Stainless steel V4A</b> 30 x 3.5 mm	10.5 mm	28 mm	1	112 017
<b>Stainless steel V4A</b> 30 x 3.5 mm	10.5 mm	43 mm	1	112 053
<b>Stainless steel V4A</b> 30 x 3.5 mm	12.5 mm	28 mm	1	112 018
<b>Stainless steel V4A</b> 30 x 3.5 mm	12.5 mm	43 mm	1	112 054
<b>Stainless steel V4A</b> 40 x 5.0 mm	16.5 mm	40 mm	1	112 046

## Connection angle



Ord. no. 112 018

Ord. no. 112 053

**Extension piece for fixed earthing terminals** on walls with insulation coating.

Specification	Insulation thickness	PU	Ord. no.
Extension piece M12 / M12 incl. spring lock washer, completely made of <b>stainless steel V4A</b> (optional use of screw set 03)	up to 100 mm	1	112 043
	up to 150 mm	1	112 044

## Extension piece for fixed earthing terminals



Ord. no. 112 043

Other disconnection clamps with terminal angle to be found on page 95.



## JP-EG - Version I



Ord. no. 113 085

## JP-EG - Version II



Ord. no. 113 260

## JP-EGL - Version I

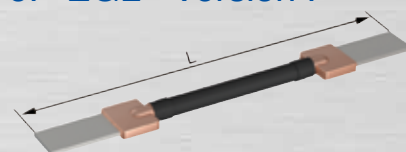

Ord. no. 113 123

## JP-EGLVP



Ord. no. 114 400

## JP-EGVP



Ord. no. 114 700

## Earthing kit, DB (German railways) approved

Earthing kit, for connecting reinforcements.

Approval: Eisenbahn Bundesamt (German railways); number of drawing 3 Ebs 15.03.19 Bl. 13

Specification	Cross section	PU	Ord. no.
<b>Version I</b> for short circuit currents $\leq 25$ kA Fixed earthing terminal $\varnothing$ 50 mm made of <b>Cu - alloy</b> ; with inner thread M16	70 mm <sup>2</sup>	1	113 085
<b>Version II</b> for short circuit currents $> 25$ kA Fixed earthing terminal $\varnothing$ 50 mm made of <b>Cu - alloy</b> ; with inner thread M16	95 mm <sup>2</sup>	1	113 105

Specify length „L“ with order.

Earthing kit, angled earthing kit, for connecting reinforcements.

Approval: Eisenbahn Bundesamt (German railways); number of drawing 3 Ebs 15.03.19 Bl. 13

Specification	Cross section	PU	Ord. no.
<b>Version I</b> for short circuit currents $\leq 25$ kA Fixed earthing terminal $\varnothing$ 50 mm made of <b>Cu - alloy</b> ; with inner thread M16	70 mm <sup>2</sup>	1	113 260
<b>Version II</b> for short circuit currents $> 25$ kA Fixed earthing terminal $\varnothing$ 50 mm made of <b>Cu - alloy</b> ; with inner thread M16	95 mm <sup>2</sup>	1	113 290

Specify length „L“ with order.

Earthing kit, for connecting reinforcements.

Approval: Eisenbahn Bundesamt (German railways); number of drawing 3 Ebs 15.03.19 Bl. 13

Specification	Cross section	PU	Ord. no.
<b>Version I</b> for short circuit currents $\leq 25$ kA 2 terminal brackets steel, bare 40 x 5.0 mm	70 mm <sup>2</sup>	1	113 123
<b>Version II</b> for short circuit currents $> 25$ kA 2 terminal brackets steel, bare 40 x 5.0 mm	95 mm <sup>2</sup>	1	113 133

Specify length „L“ with order.

Earthing kit, crimped with terminal brackets

Approval: Eisenbahn Bundesamt (German railways); number of drawing 3 Ebs 15.03.19 Bl. 22

Specification	Cross section	PU	Ord. no.
<b>Version I</b> for short circuit currents $\leq 25$ kA 2 terminal brackets steel ( <b>coppered</b> )	70 mm <sup>2</sup>	1	114 400
<b>Version II</b> for short circuit currents $> 25$ kA 2 terminal brackets steel ( <b>coppered</b> )	95 mm <sup>2</sup>	1	114 550

Specify length „L“ with order.

Earthing kit, crimped

Approval: Eisenbahn Bundesamt (German railways); number of drawing 3 Ebs 15.03.19 Bl. 22

Specification	Cross section	PU	Ord. no.
<b>Version I</b> for short circuit currents $\leq 25$ kA Fixed earthing terminal $\varnothing$ 50 mm made of <b>Cu - alloy</b> ; with inner thread M16	70 mm <sup>2</sup>	1	114 700
<b>Version II</b> for short circuit currents $> 25$ kA Fixed earthing terminal $\varnothing$ 50 mm made of <b>Cu - alloy</b> ; with inner thread M16	95 mm <sup>2</sup>	1	114 850

Specify length „L“ with order.





## Earthing terminal, with weld-on lug for connecting to the reinforcement.

Approval: Eisenbahn Bundesamt (German railways); number of drawing 3 Ebs 15.03.19 Bl. 13

Specification	PU	Ord. no.
<b>for short circuit currents &gt; 25 kA</b> fixed earthing terminal $\varnothing$ 50 mm made of <b>Cu - alloy</b> ; with inner thread M16, welded with terminal bracket steel, bare 40 x 5.0 mm	1	113 216

Specify length „L“ with order.

## Earthing connector, for the bridging connection of earthing terminals or earthing kits.

Approval: Eisenbahn Bundesamt; number of drawing 3 Ebs 15.03.01 and 4 Ebs 15.03.17

Specification	Cross section	PU	Ord. no.
<b>Version I for short circuit currents <math>\leq</math> 25 kA</b> with heat shrink tubing (on both sides) copper cable with plastic coating (NYY-0)	50 mm <sup>2</sup>	1	113 029
<b>Version I for short circuit currents &gt; 25 kA</b> with heat shrink tubing (on both sides) copper cable with plastic coating (NYY-0)	70 mm <sup>2</sup>	1	113 030

Specify length „L“ with order.

## Earthing material and earthing conductor

(Operative range, e.g. German armed forces / technical containers)

### Earthing cable lug brass/galSn for earthing conductors,

frost-resistant up to -40°C.

Specification	Cross section	PU	Ord. no.
Cable lug open	6 - 16 mm <sup>2</sup>	100	T 14 A 0001 A
Cable lug closed; $\varnothing$ 8.5 mm	6 - 16 mm <sup>2</sup>	100	T 14 B 0001 A
Cable lug closed; $\varnothing$ 10.5 mm	6 - 16 mm <sup>2</sup>	100	T 14 B 0002 A

### Earthing conductor made of highly flexible copper, frost-resistant up to -40°C.

Specification	Cross section	PU	Ord. no.
<b>Copper</b>	10 mm <sup>2</sup>	running metre	410 000
<b>Copper</b>	16 mm <sup>2</sup>	running metre	416 000

Possible combinations.



Marker sleeves for the conductors on request.

## Earthing terminal JP-EAG (straight)

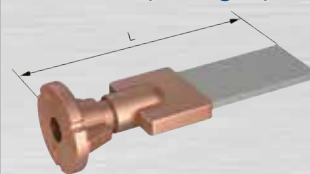

Ord. no. 113 216

## Earthing connector JP-EV



Ord. no. 113 029

## Earthing cable lug open or closed



Ord. no.  
T 14 A 0001 A

Ord. no.  
T 14 B 0001 A

Ord. no.  
T 14 B 0002 A

## Earthing conductor

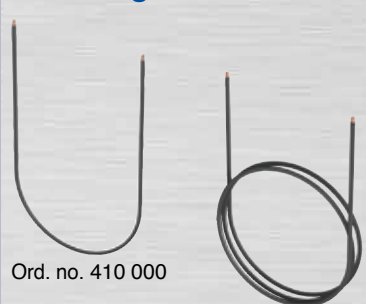

Ord. no. 410 000

Ord. no. 416 000

Earthing material





# Equipotential bonding



Equipotential bonding



## Equipotential bonding bars

### Benefits Equipotential bonding bar with metal cover:

- Terminal screws with spring lock washer against self-loosening.
- Connection possible from top or bottom.
- Captive screws are individually removeable if needed.
- Unbreakable aluminium cover, lead-sealable.
- Low profile installation.
- Bus bar numbering of the individual clamping points.
- Simple installation – only two screws needed for mounting.

### Equipotential bonding bar with metal cover (J.P. utility patent)



Ord. no. 111 075

Equipotential bonding bar with aluminium cover,  
for equipotential bonding according to EN 62305-3 and IEC 60364-4-41/60364-5-54.

Specification	PU	Ord. no.
Suitable for the connection of:	1	111 075
1 x flat conductor up to 30 x 5.0 mm or $\varnothing$ 8-10 mm		
1 x round conductor 25 - 95 mm <sup>2</sup> ( $\varnothing$ 4-12 mm) single-core/stranded		
7 x conductor 2.5 - 25 mm <sup>2</sup> ( $\varnothing$ 1-7.5 mm) single-core/stranded finely stranded (with ferrule)		

Connection piece to extend the equipotential bonding bar (111 075).

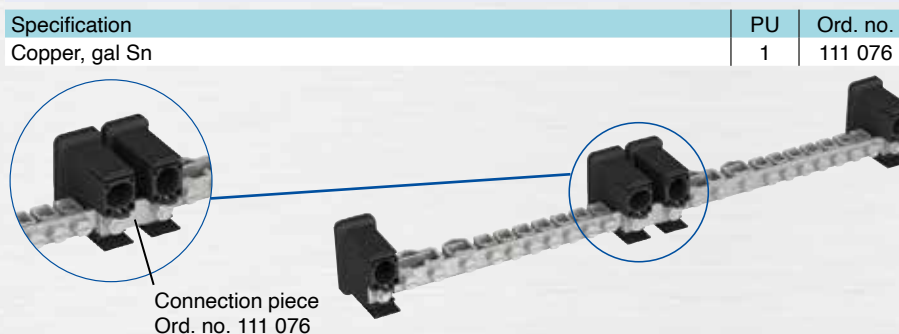

Specification	PU	Ord. no.
Copper, gal Sn	1	111 076

### Equipotential bonding bar

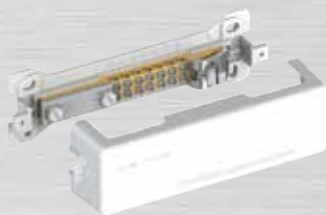

Ord. no. 111 070

### Test joint box with equipotential bonding bar



Ord. no. 111 590

Equipotential bonding bar with plastic cover,  
for equipotential bonding according to IEC 60364-4-41/60364-5-54.

Specification	PU	Ord. no.
Suitable for the connection of:	1	111 070
1 x flat conductor up to 30 x 5 mm or $\varnothing$ 8-10 mm		
1 x round conductor $\varnothing$ 8-12 mm		
7 x conductor up to 25 mm <sup>2</sup> single-core/stranded or 16 mm <sup>2</sup> finely stranded		

Test joint box with equipotential bonding bar,  
for external thermal insulation composite systems.

Specification	Installation depth	PU	Ord. no.
Dimensions of box: (196 x 158 mm)	90 - 140 mm	1	111 590
Bonding bar with terminals for			
- 1 x conductor fl. up to 30x5 mm or $\varnothing$ 8-10 mm			
- 1 x conductor $\varnothing$ 8-12 mm			
- 7 x conductor up to 25 mm <sup>2</sup> (single-core/stranded) or 16 mm <sup>2</sup> (finely stranded)			
Material contact bar: brass including V2A cover (220 x 180 mm) with affixed seal.			
Plastic material is self-extinguishing and halogen-free. V2A cover confirms to degree of protection IP65.			

Cover with company logo on request. Price on application.



**Bonding bar**, for equipotential bonding according to IEC 60364-4-41/60364-5-54 and for lightning equipotential bonding according to EN 62305, complete with screws M10x25 mm, nuts, spring lock washers and insulators. Delivery incl. fastening screws.

Specification	Specification screws	Number of terminals	Dimensions Length / width x thickness	PU	Ord. no.
Copper	V2A	5	220 / 40 x 5 mm	1	910 009
Copper	V2A	6	250 / 40 x 5 mm	1	2072
Copper	V2A	8	310 / 40 x 5 mm	1	910 375
Copper	V2A	10	370 / 40 x 5 mm	1	910 139
Copper	V2A	12	430 / 40 x 5 mm	1	910 193
Copper	V2A	14	490 / 40 x 5 mm	1	910 010
Copper	V2A	15	520 / 40 x 5 mm	1	910 359
Copper	V2A	16	550 / 40 x 5 mm	1	910 527
Copper	V2A	18	640 / 40 x 5 mm	1	910 540
Copper	V2A	20	700 / 40 x 5 mm	1	910 382
Stainless steel V2A	V2A	5	220 / 40 x 5 mm	1	910 011
Stainless steel V2A	V2A	6	250 / 40 x 5 mm	1	112 082
Stainless steel V2A	V2A	8	310 / 40 x 5 mm	1	910 385
Stainless steel V2A	V2A	10	370 / 40 x 5 mm	1	910 302
Stainless steel V2A	V2A	12	430 / 40 x 5 mm	1	910 012
Stainless steel V2A	V2A	14	490 / 40 x 5 mm	1	910 013
Stainless steel V2A	V2A	15	520 / 40 x 5 mm	1	910 018
Stainless steel V2A	V2A	16	550 / 40 x 5 mm	1	910 019
Stainless steel V2A	V2A	18	640 / 40 x 5 mm	1	910 020
Stainless steel V2A	V2A	20	700 / 40 x 5 mm	1	910 022

**Note:** Secured against rotation with carriage bolt!

**Cover** with fastening screws stainless steel V2A.

Specification	Number of terminals	Length	PU	Ord. no.
Stainless steel V2A	5	220 mm	1	9105
Stainless steel V2A	6	250 mm	1	9106
Stainless steel V2A	8	310 mm	1	9108
Stainless steel V2A	10	370 mm	1	9110

**Additional specifications (e.g. Aluminium) or sizes on request**

Additional dimensions, hole spacings, hole diameters or types of connection (e.g. KS-connector or Vario-clamp for flat strips) available on request.

**Multi-Mini saddle clamp** for equipotential bonding.  
Conductor connection lengthwise or crosswise. Clamping range up to 8 mm.

Specification	Fit	PU	Ord. no.
Stainless steel V2A	6 mm <sup>2</sup> (ø 2.8 mm) - 50 mm <sup>2</sup> (ø 8 mm)	100	111 780
Stainless steel V2A/coppered	6 mm <sup>2</sup> (ø 2.8 mm) - 50 mm <sup>2</sup> (ø 8 mm)	100	111 781
Steel, hot galvanized	6 mm <sup>2</sup> (ø 2.8 mm) - 50 mm <sup>2</sup> (ø 8 mm)	100	111 782

Example of application:



## Bonding bar flat



Ord. no. 2072



Ord. no. 112 082

## Stainless steel cover



Ord. no. 9106

Example of application  
Aluminium cover:

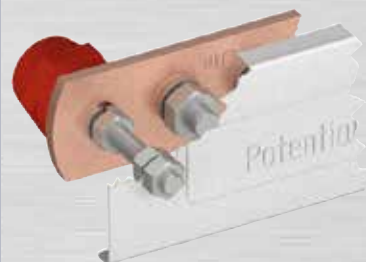

## Multi-Mini saddle clamp



Ord. no. 111 780



## Single row



Ord. no. 913 653

## Single row with connection screws



Ord. no. 910 306

## Double row



Ord. no. 913 662

## Double row with connection screws



Ord. no. 910 380

## Earthing busbar (angled)

Earthing busbar, wall distance (height ~ 35 mm); connecting bores  $\varnothing$  10.5 mm.

Specification	Number of terminals	Dimensions	PU	Ord. no.
		Length / width x thickness		
Stainless steel V2A	2	135 / 30 x 3.5 mm	1	913 650
Stainless steel V2A	3	165 / 30 x 3.5 mm	1	913 651
Stainless steel V2A	4	195 / 30 x 3.5 mm	1	913 652
Stainless steel V2A	5	225 / 30 x 3.5 mm	1	913 653
Stainless steel V2A	6	255 / 30 x 3.5 mm	1	913 654
Stainless steel V2A	7	285 / 30 x 3.5 mm	1	913 655
Stainless steel V2A	8	315 / 30 x 3.5 mm	1	913 656
Stainless steel V2A	9	345 / 30 x 3.5 mm	1	913 657
Stainless steel V2A	10	375 / 30 x 3.5 mm	1	913 658

Earthing busbar, wall distance (height ~ 35 mm),  
Including screws M10x25 mm, nuts, spring lock washers.

Specification	Specification screw	Number of terminals	Dimensions	PU	Ord. no.
			Length / width x thickness		
Stainless steel V2A	V2A	2	135 / 30 x 3.5 mm	1	910 330
Stainless steel V2A	V2A	3	165 / 30 x 3.5 mm	1	910 331
Stainless steel V2A	V2A	4	195 / 30 x 3.5 mm	1	910 305
Stainless steel V2A	V2A	5	225 / 30 x 3.5 mm	1	910 306
Stainless steel V2A	V2A	6	255 / 30 x 3.5 mm	1	910 307
Stainless steel V2A	V2A	7	285 / 30 x 3.5 mm	1	910 332
Stainless steel V2A	V2A	8	315 / 30 x 3.5 mm	1	910 308
Stainless steel V2A	V2A	9	345 / 30 x 3.5 mm	1	910 333
Stainless steel V2A	V2A	10	375 / 30 x 3.5 mm	1	910 309

Earthing busbar, wall distance (height ~ 65 mm); connecting bores  $\varnothing$  10.5 mm.

Specification	Number of terminals	Dimensions	PU	Ord. no.
		Length / width x thickness		
Steel, hot galvanized	2 x 2	225 / 60 x 5 mm	1	913 666
Steel, hot galvanized	2 x 4	305 / 60 x 5 mm	1	913 667
Steel, hot galvanized	2 x 6	385 / 60 x 5 mm	1	913 668
Stainless steel V2A	2 x 2	225 / 60 x 5 mm	1	913 660
Stainless steel V2A	2 x 4	305 / 60 x 5 mm	1	913 661
Stainless steel V2A	2 x 6	385 / 60 x 5 mm	1	913 662

Earthing busbar, wall distance (height ~ 65 mm),  
Including screws M10x25 mm, nuts, spring lock washers.

Specification	Specification screw	Number of terminals	Dimensions	PU	Ord. no.
			Length / width x thickness		
Steel, hot galvanized	V2A	2 x 2	225 / 60 x 5 mm	1	910 223
Steel, hot galvanized	V2A	2 x 4	305 / 60 x 5 mm	1	910 023
Steel, hot galvanized	V2A	2 x 6	385 / 60 x 5 mm	1	910 301
Stainless steel V2A	V2A	2 x 2	225 / 60 x 5 mm	1	910 544
Stainless steel V2A	V2A	2 x 4	305 / 60 x 5 mm	1	910 545
Stainless steel V2A	V2A	2 x 6	385 / 60 x 5 mm	1	910 380

Additional dimensions, hole spacings, hole diameters or types of connection (e.g. KS-connector or Vario-clamp for flat strips) available on request.



# Insulated lightning protection

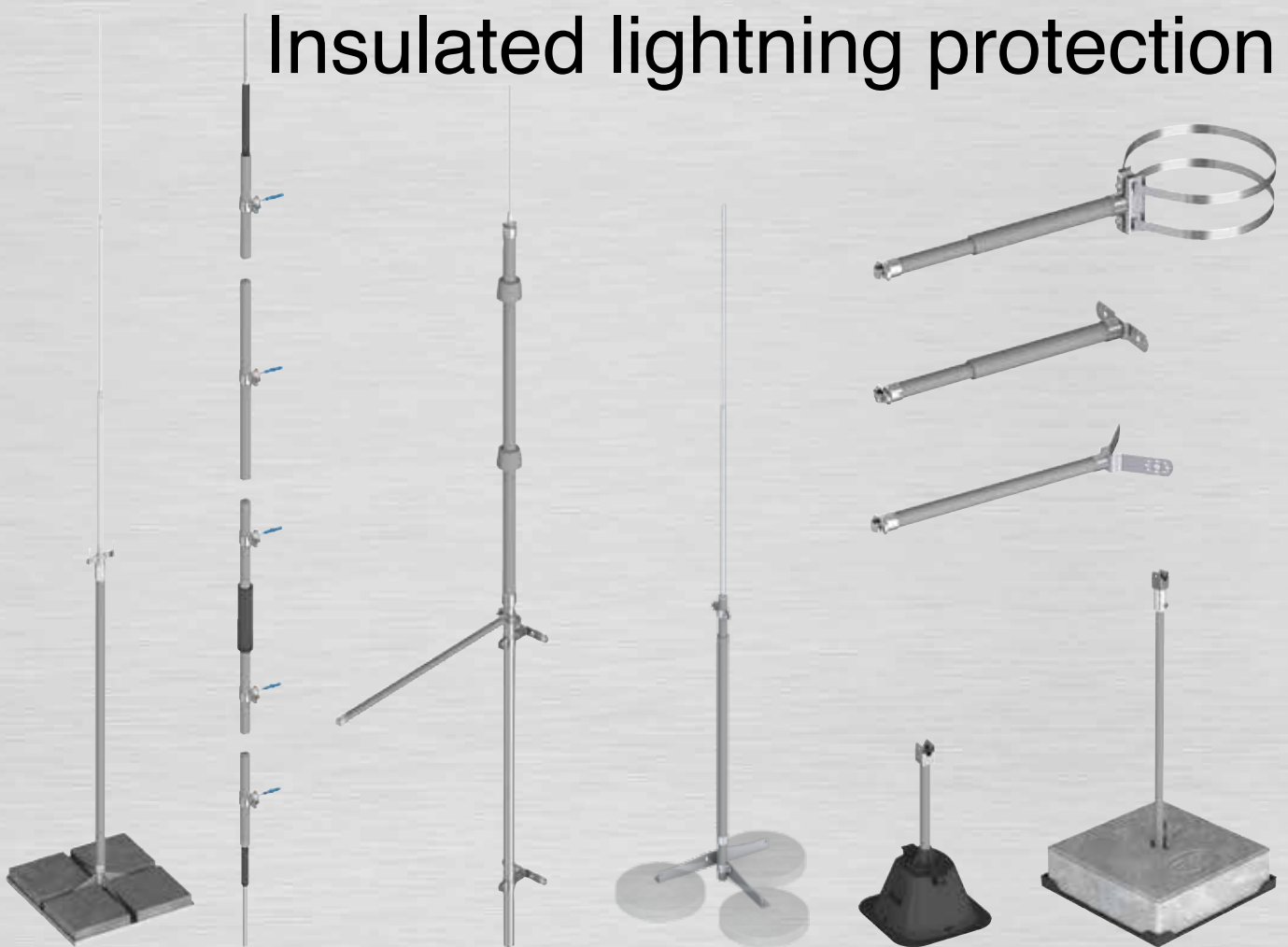

Insulated lightning protection

Please also ask for our special catalogue:





Ord. no. 111 496

## Air termination pole base frame



Ord. no. 499 000

## Support plate



Ord. no. 499 010

## Interesting facts about insulated lightning protection systems

Generally, we differentiate between insulated and partially insulated lightning protection systems. Partially insulated systems are most common. To design such a system, the well-known mesh method is used to install an air termination system. The area with roof installations is then additionally equipped with insulated air termination rods.

A decisive advantage of insulated or partially insulated lightning protection systems consists in the fact that no partial lightning currents can penetrate into the building.

J.Pröpster offers an easy-to-assemble and well proved lightning protection system that guarantees maximum protection for your equipment.

### Air termination pole for insulated air termination systems

without lateral stand-off - to support long conductors.

Specification according to EN 62305-3 / EN 62561-2:

**Air termination tip:** Aluminium 0.75 m above air termination conductor

**Insulated support:** GRP 1.5 m

**Stand pipe length:** Stainless steel V2A variable (ø 42 mm)

Conductor height	Total height	Stand-offs	Mounting clamps	PU	Ord. no.
3.0 m	3.75 m	without	2	1	111 496
3.5 m	4.25 m	without	2	1	111 497

Additional lengths or combinations on request.

3.0 m	3.75 m	without	without	1	112 496
3.5 m	4.25 m	without	without	1	112 497

Additional lengths or combinations on request.

### Air termination pole base frame with roof inclination adjustment up to 5°.

For concrete bases 300 x 300 mm to position air termination poles ø 42 mm (e.g. 111 496).

Specification	Footprint	PU	Ord. no.
Stainless steel V2A	ca. 650 x 650 mm	1	499 000
Support plate (one side aluminium-laminated)	ca. 650 x 650 mm	1	499 010
Roof inclination adjustment, inclination up to 10°		1	499 700



Roof inclination adjustment up to 5°

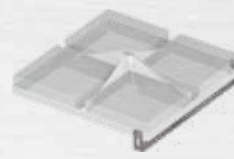

Roof inclination adjustment up to 10°

Ord. no. 499 700.

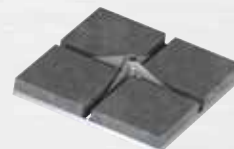

Air termination pole base frame with optional concrete bases  
Ord. no. 499 100.





## Insulated air termination pole

**Air termination pole for insulated air termination systems**  
with lateral stand-off, to protect roof installations from direct lightning strikes.

Specification according to EN 62305-3 / EN 62561-2:

<b>Air termination tip:</b> Aluminium	0.75 m above air termination conductor
<b>Insulated support:</b> GRP	1.5 m
<b>Stand-off length:</b> GRP	1.0 m
<b>Stand pipe length:</b> Stainless steel V2A	variable (ø 42 mm)

Conductor height	Total height	Stand-offs	Mounting clamps	PU	Ord. no.
3.0 m	3.75 m	1	2	1	111 490
3.5 m	4.25 m	1	2	1	111 491
4.0 m	4.75 m	1	2	1	111 492
4.5 m	5.25 m	2	3	1	111 493
5.0 m, 2-parts	5.75 m	2	3	1	111 494
5.5 m, 2-parts	6.25 m	2	3	1	111 495



## Air termination pole for insulated systems

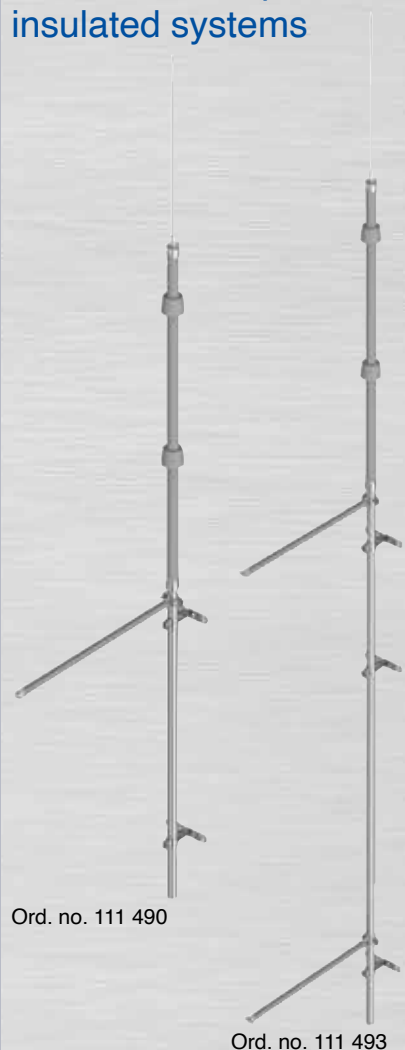

Ord. no. 111 490

Ord. no. 111 493

**Insulated stand-off**, with pipe clamp, height-adjustable on the stand pipe V2A ø 42 mm (air termination pole) with clamping component for aluminium conductor ø 8-10 mm.

Specification	PU	Ord. no.
0.5 m	1	490 405 V
0.8 m	1	490 408 V
1.0 m	1	490 410 V

Additional lengths on request!

## Insulated stand-off with pipe clamp



Ord. no. 490 405 V

**Air termination conductor**, for free tension over the protected equipment

Specification	Fit	Weight/m	PU	Ord. no.
Aldrey cable	50 mm <sup>2</sup>	~ 0.135 kg	rm	100 058

## Aldrey cable



Ord. no. 100 058



## Air termination pole fastener



Ord. no. 490 491

Ord. no. 490 495

## Air termination pole fastener



Ord. no. 490 540

## Rafter fastener



Ord. no. 1230

## Roof bushing-SET

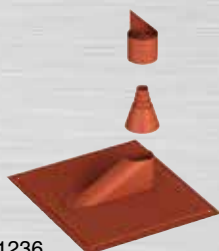

Ord. no. 1236

## Air termination pole fastener



Ord. no. 1237

**Air termination pole fastener** for steel constructions (e.g. side rails) consisting of: Holder V2A on profile and pole holder V2A (cross clamp).

Specification	Profile	Fit in inch	Square profile	PU	Ord. no.
<b>Round profile</b>					
Stainless steel V2A	ø 26.9 mm	3/4"		1	490 490
Stainless steel V2A	ø 42.4 mm	1 1/4"		1	490 491
Stainless steel V2A	ø 48.3 mm	1 1/2"		1	490 492
<b>Square profile</b>					
Stainless steel V2A		suitable for	20 x 20 mm to 50 x 50 mm	1	490 495

Additional diameters and dimensions on request.

**Air termination pole fastener** for poles up to 5.5 m height and ø 42 mm. Tape pipe clamp V2A for clamping range up to 800 mm.

Specification	Wall distance	PU	Ord. no.
<b>NEW</b> Completely in stainless steel V2A for ø 42 mm pole clamp with 2 x screws M10, spring lock washer and nut in V2A	150 mm	1	490 540
Tape pipe clamp with 2 x screws M8 V2A	200 mm	1	490 541
	250 mm	1	490 542
	300 mm	1	490 543

**Rafter fastener**, for mounting poles up to 4.0 m height on tiled roofs. incl. fixing screw-SET made of V2A (also suitable for poles for HVC).

Specification	Rafter distance	Roof pitch	Dimensions	PU	Ord. no.
<b>NEW</b> St/tZn	550 mm - 900 mm	up to 80°, infinitely adjustable	Ø 48 mm Height 800 mm	1	1230

**Roof bushing-SET**, suitable for rafter fastener (Ord. no. 1230) with rubber grommet and sealing strip (self-welding).

Specification	Rafter distance	Roof pitch	Colour	PU	Ord. no.
<b>NEW</b> Aluminium with plastic coating (UV-stabilized)	500 mm x 450 mm	up to 56°	anthracite	1	1235
			red	1	1236

**Air termination pole fastener**, completely in stainless steel V2A composed of 2x parallel clamp for Ø 48 mm onto Ø 42.4 mm. Suitable for rafter fastener (Ord. no. 1230).

Specification	Fit (mm)	Fit (inches)	PU	Ord. no.
<b>NEW</b> Stainless steel V2A	Ø 48 mm onto Ø 42.4 mm	1 1/2" onto 1 1/4"	1	1237

**Note: The Installation must be clarified with the building owner on site.**



## RS-Telescopic-air termination pole, free-standing aluminium with base frame for roof inclinations up to 10°

RS-Telescopic-air termination pole, free-standing incl. base frame with roof inclination adjustment, connection clamp, 4 concrete bases and support plates.

Height of pole	Pole parts	Base frame	Concrete base	Ord. no.
<b>NEW!</b> up to 4.35 m (1.7 m GRP)	4-part	499 000 (5°)	4x 16 kg	912 605

Note: The air termination pole base frame must be secured against slipping from a roof inclination of 5°. Roof inclination adjustment up to 10° (ord. no. 499 700) for the base frame (ord. no. 499 000) see on page 154.  
**transport / delivery length ca. 2.2 m**

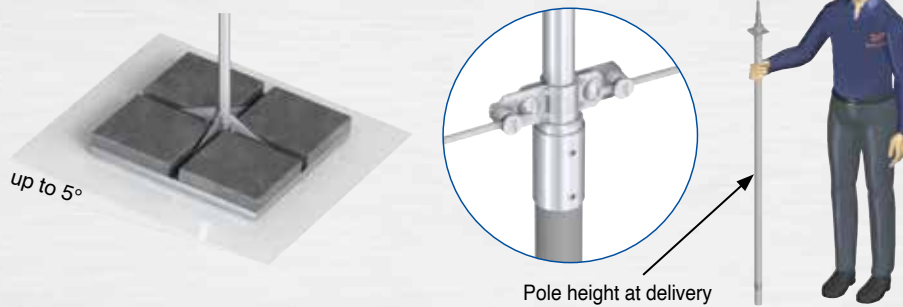

Wind speed according to Eurocode:

Height of pole	SET ord. no.	Wind speed	
		Static safety factor 1.0	Static safety factor 1.5
up to 4.35 m	912 605	162 km/h	144 km/h

## Insulated air-termination rod

Air-termination rod-SET insulated - in GRP/stainless steel V2A with aluminium-air-termination tip. With angle-base frame stainless steel V2A 80x50x5mm for 1, 2 resp. 3 concrete base round.

Specification	Footprint (mm)	Concrete base (optional)	Wind speed		Height	Ord. no.
			Static safety factor 1.5			
GRP ø 32 1.0m / Stainless steel V2A / Aluminium	ø 420	1x 25 kg (Ord. no. 103 118)	145 km/h		<b>2.0 m</b>	912 803
GRP ø 32 1.0m / Stainless steel V2A / Aluminium	ca. 930 x 380	2x 16 kg (Ord. no. 103 101)	145 km/h		<b>2.5 m</b>	912 800
GRP ø 32 1.0m / Stainless steel V2A / Aluminium	ca. 970 x 420	2x 25 kg (Ord. no. 103 118)	145 km/h		<b>3.0 m</b>	912 801
GRP ø 48 1.1m / Stainless steel V2A / Aluminium	ca. 970 x 830	3x 25 kg (Ord. no. 103 118)	145 km/h		<b>3.5 m</b>	912 802

Note: Concrete bases (round) and support plates (ord. no. 103 102) must be ordered separately.

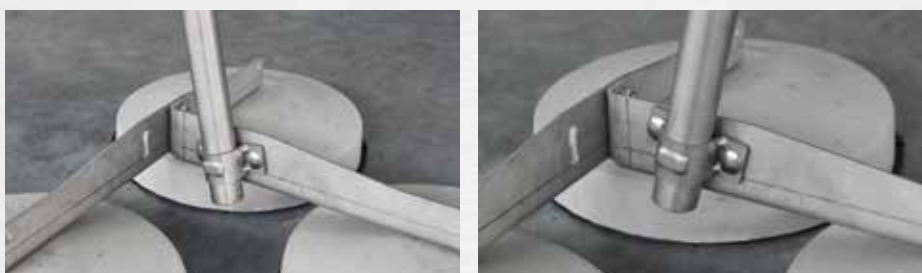

**NEW!** With integrated roof inclination adjustment up to 10° and connection possibility (square 11 mm) in all corners

## RS-Telescopic-air termination pole

5°



Ord. no. 912 605

## Air-termination rod



Ord. no. 912 800

Ord. no. 912 802



with integrated roof inclination adjustment up to 10°

Insulated lightning protection



### Insulated stand-off with mounting plate



Ord. no. 490 433 S



Ord. no. 490 430

### Insulated stand-off with tape clamp



Ord. no. 490 443



Ord. no. 490 513

### Insulated stand-off - heavy-duty type

- All stand-offs for air termination rods (Al)  $\varnothing$  16 mm and down conductors  $\varnothing$  8-10 mm
- Insulated stand-off for free carrying of aluminium air termination rods

#### Insulated stand-off with flat mounting plate (stainless steel V2A) for mounting on walls and metal sheets.

Specification	Length	PU	Ord. no.
<b>Infinitely adjustable:</b>	350 - 500 mm	1	490 433 S
<b>Telescopic insulated stand-off GRP, <math>\varnothing</math> 32/40 mm</b> for $\varnothing$ 16 mm and $\varnothing$ 8-10 mm	650 - 1000 mm	1	490 433
<b>with fixed length:</b>	0.5 m	1	490 430
<b>Insulated stand-off GRP, <math>\varnothing</math> 32 mm</b> for $\varnothing$ 16 mm and $\varnothing$ 8-10 mm	0.8 m	1	490 431
	1.0 m	1	490 432



#### Insulated stand-off with tape pipe clamp (stainless steel V2A).

Specification	Length	PU	Ord. no.
<b>Infinitely adjustable:</b>	350 - 500 mm	1	490 443
<b>Telescopic insulated stand-off GRP, <math>\varnothing</math> 32/40 mm</b> for $\varnothing$ 16 mm and $\varnothing$ 8-10 mm tape pipe clamp max. $\varnothing$ 800 mm	650 - 1000 mm	1	490 444
<b>with fixed length:</b>	0.5 m	1	490 513
<b>Insulated stand-off GRP, <math>\varnothing</math> 32 mm</b> for $\varnothing$ 16 mm and $\varnothing$ 8-10 mm tape pipe clamp max. $\varnothing$ 800 mm	0.8 m	1	490 514
	1.0 m	1	490 515





**Insulated stand-off** with mounting bracket for rotatable or adjustable fixing elements.  
The insulated stand-off is adjustable in all directions.

Specification	Length	PU	Ord. no.
<b>Infinitely adjustable:</b>			
<b>Telescopic insulated stand-off GRP</b> , ø 32/40 mm mounting bracket ø 12.5 mm, for ø 16 mm and ø 8-10 mm	350 - 500 mm	1	490 535
	650 - 1000 mm	1	490 536
<b>with fixed length:</b>			
<b>Insulated stand-off GRP</b> , ø 32 mm mounting bracket ø 12.5 mm, for ø 16 mm and ø 8-10 mm	0.5 m	1	490 530
	0.8 m	1	490 531
	1.0 m	1	490 532



**Fixing element** for insulated stand-off with bracket.

Specification	Clamping range	PU	Ord. no.
Fixing element <b>stainless steel V2A</b> with mounting plate including installation material for the insulated stand-offs (screw M12x20, spring washer and hexagonal nut)	-	1	490 505
Fixing element <b>stainless steel V2A</b> with two terminal clamps, heavy-duty type including installation material for the insulated stand-offs (screw M12x20, spring washer and hexagonal nut)	5 - 19 mm	1	490 506
	19 - 36 mm	1	490 507
	36 - 52 mm	1	490 508

## Insulated stand-off with fixing bracket



Ord. no. 490 535



Ord. no. 490 530

## Fixing element (adjustable in all directions)



Ord. no. 490 505



Ord. no. 490 506

**Insulated stand-off** for mounting on corners and building edges.

Specification	Length	PU	Ord. no.
<b>with fixed length:</b>			
Insulated stand-off GRP ø 32 mm for ø 16 mm and ø 8-10 mm	0.5 m	1	490 450
	0.8 m	1	490 451
	1.0 m	1	490 452

Additional stand-off lengths on request!

## Insulated stand-off for corner mounting



Ord. no. 490 450



Insulated stand-offs -  
- light-weight design  
Individual combinations!

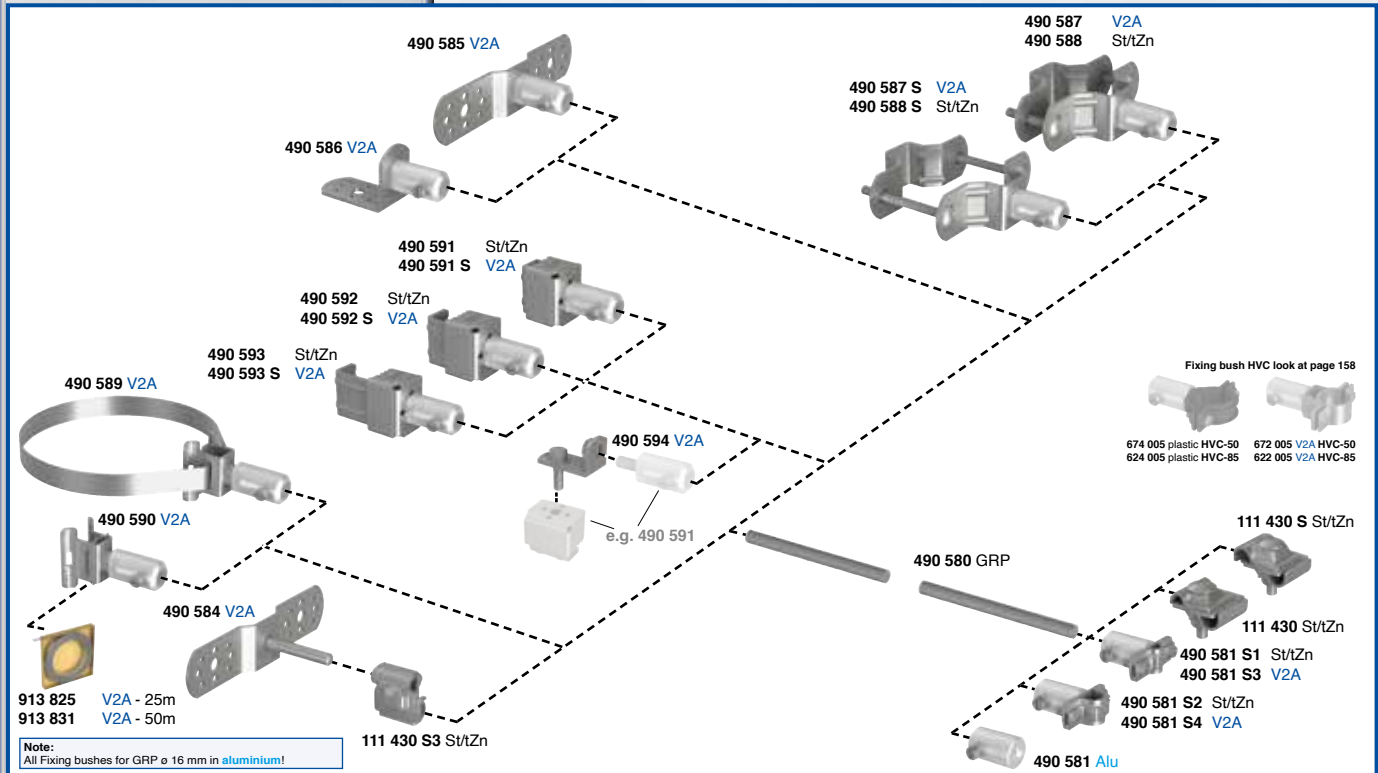

## Fixing bush



## Multi-clamp



## Solid rod GRP

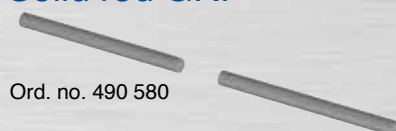

## Fixing side conductor or air termination rod:

Fixing bush with fastener for fixing air termination rods ø 16 mm and down conductors ø 8-10 mm to the solid rod GRP ø 16 mm.

Specification	Length	PU	Ord. no.
Fixing bush <b>aluminium</b> , for GRP ø 16 mm; <b>for air termination rods ø 16 mm</b>			
with fastener steel, hot galvanized, for ø 16 mm	40 mm	25	490 581 S2
with fastener <b>stainless steel V2A</b> , for ø 16 mm	40 mm	25	490 581 S4

Specification	Length	PU	Ord. no.
Fixing bush <b>aluminium</b> , for GRP ø 16 mm; <b>for down conductors ø 8 - 10 mm</b>			
with fastener steel, hot galvanized, for ø 8-10 mm	40 mm	25	490 581 S1
with fastener <b>stainless steel V2A</b> , for ø 8-10 mm	40 mm	25	490 581 S3
with inner thread M6	40 mm	25	490 581

## Multi-clamp

Specification	Fit	PU	Ord. no.
Steel, hot galvanized	ø 16 / ø 16 mm	25	111 430 S
Steel, hot galvanized	ø 8-10 / ø 16 mm	50	111 430

## Solid rod GRP:

to be cut to length.

Specification	Length	PU	Ord. no.
Solid rod GRP, ø 16 mm	3.0 m	10	490 580



## Fixing side object:

**Mounting plate and angle bracket** for mounting on walls and metal sheets, with fixing bush **aluminium**, for GRP  $\varnothing$  16 mm.

Specification	PU	Ord. no.
Mounting plate <b>stainless steel V2A</b>	25	490 585 
Angle bracket <b>stainless steel V2A</b>	25	490 586
Fixing bush <b>aluminium</b> , for GRP $\varnothing$ 16 mm with hexagonal screw M10 x 16 <b>stainless steel V2A</b>	25	490 582

## Mounting plate and angle bracket



**Mounting plate with bolt** for mounting on walls and metal sheets.

Specification	PU	Ord. no.
Mounting plate with bolt $\varnothing$ 10 mm <b>stainless steel V2A</b> / 60 mm	25	490 584 
Multi-clamp steel, hot galvanized ( $\varnothing$ 10 / $\varnothing$ 16 mm)	50	111 430 S3

## Mounting plate with bolt

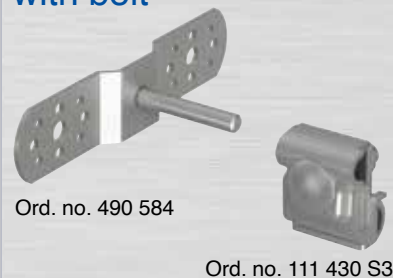

**Terminal clamp, heavy-duty type** for mounting on steel constructions or railings, with fixing bush **aluminium**, for GRP  $\varnothing$  16 mm.

Specification	Clamping range	PU	Ord. no.
Steel, hot galvanized	5 - 19 mm	25	490 591
Steel, hot galvanized	19 - 36 mm	25	490 592
Steel, hot galvanized	36 - 52 mm	25	490 593
<b>Stainless steel V2A</b>	5 - 19 mm	25	490 591 S 
<b>Stainless steel V2A</b>	19 - 36 mm	25	490 592 S
<b>Stainless steel V2A</b>	36 - 52 mm	25	490 593 S

## Terminal clamp, heavy-duty type

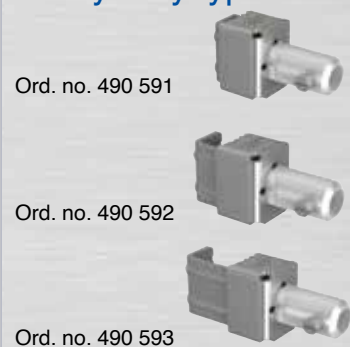

Angle bracket **stainless steel V2A**, for terminal clamp, with hexagonal screw, nuts and spring lock washer

PU	Ord. no.
25	490 594 

**Pipe clamp** for mounting on pipes or railings with fixing bush **aluminium**, for GRP  $\varnothing$  16 mm.

Specification	Fit	Fit in inch	PU	Ord. no.
Pipe clamp <b>stainless steel V2A</b> with fixing screws in <b>stainless steel V2A</b>	$\varnothing$ 42.4-60.3 mm	1 1/4" - 2"	20	490 587 
	$\varnothing$ 42.4-88.9 mm	1 1/4" - 3"	20	490 587 S
Pipe clamp steel, hot galvanized with fixing screws in <b>stainless steel V2A</b>	$\varnothing$ 42.4-60.3 mm	1 1/4" - 2"	20	490 588
	$\varnothing$ 42.4-88.9 mm	1 1/4" - 3"	20	490 588 S

## Pipe clamp

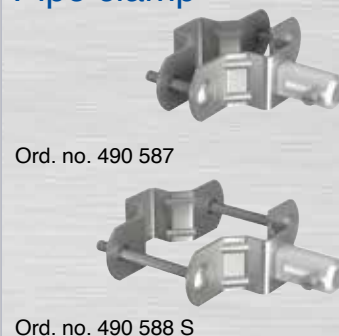

**Pipe clamp** for mounting on pipes up to  $\varnothing$  300 mm with fixing bush **aluminium** for GRP  $\varnothing$  16 mm.

Specification	Pipe- $\varnothing$	PU	Ord. no.
Pipe clamp with tensioning strap <b>stainless steel V2A</b>	max. $\varnothing$ 300 mm	10	490 589 
Pipe clamp without tensioning strap <b>stainless steel V2A</b>	--	20	490 590
tensioning strap <b>stainless steel V2A</b> , 22 x 0.4 mm	--	25 m	913 825
	--	50 m	913 831

## Tape pipe clamp



**Note:** For sheet metal chimneys, use an intermediate plate (e.g.: a piece of VA-sheet)



## Insulated stand-off - light-weight types

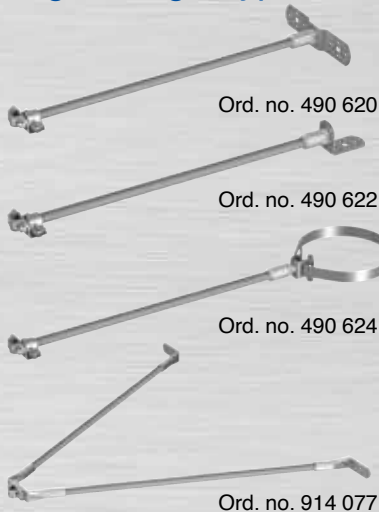

**Insulated stand-off**, light-weight type for the fixation of air termination rods with concrete base. Stand-off GRP  $\varnothing$  16 mm for air termination rods **aluminium**  $\varnothing$  16 mm.

Specification	Length	PU	Ord. no.
with mounting plate	0.50 m	1	490 620
	0.75 m	1	490 621
with angle bracket	0.50 m	1	490 622
	0.75 m	1	490 623
with tape pipe clamp up to $\varnothing$ 300 mm	0.50 m	1	490 624
	0.75 m	1	490 625
<b>V-shape</b> with mounting lugs (Actual insulated distance 600 mm)	0.60 m	1	914 077

## GRP-attic

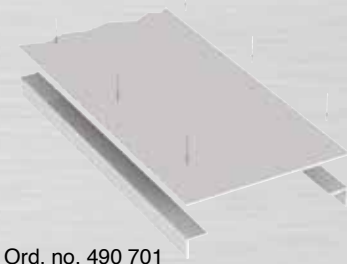

**JP-plastic attic made of GRP**, for replacing metal attics with non-conducting material to control the separation distance.

Specification	Length	PU	Ord. no.
GRP-flat section (light grey) 450x3 mm	3.0 m	1	490 700
GRP-angle section (light grey) 60x40x3 mm	3.0 m	1	490 701

Note: flat and angle section are without bore holes and rivets (see page 118).

Accessories	PU	Ord. no.
Cleaning spray for GRP surfaces	1	490 702
Elastic universal adhesive and sealant	1	490 703

## Bridging-SET



## Bridging-SET

to bridge continuous rooflights or other roof structures. \*)

Specification	Height	Width	PU	Ord. no.
<b>Bridging complete in aluminium telescopic</b> $\varnothing$ 32/22/16/10 mm with fixing elements- <b>stainless steel V2A</b> incl. concrete bases and support plates	1.75 - 2.5 m	3.0 - 4.0 m	1	490 303

\*) The aluminium air termination rod  $\varnothing$  10 mm, can be shortened to 1000 mm on site.  
Possible width: 2.5 m

**Additional types on request.**

max. Wind speed according to Eurocode:

Ord. no.	Wind speed	
	Static safety factor 1.0	Static safety factor 1.5
490 303	160 km/h	130 km/h

Example of application:







## Insulated conductor support (complete SET)

to raise the conductor leading

Insulated conductor support, to raise the conductor on flat roofs with plastic base 2 kg and Niro-Clip for ø 8 mm \*) **Type A (fL)**.

Specification	Height	Insulated-length	PU	Ord. no.
Conductor support GRP ø 16 mm for air termination conductor ø 8 mm / 50 mm <sup>2</sup>	0.2 m	0.17 m	1	490 000
	0.3 m	0.27 m	1	490 001
	0.4 m	0.37 m	1	490 002

\*) **Type A (fL)** = fixed conductor /leading

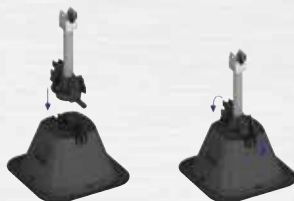

Insulated conductor support, to raise the conductor on flat roofs with square concrete base 16 kg, V2A wedge, support plate and Niro-Clip for ø 8 mm \*) **Type A (fL)**.

Specification	Height	Insulated-length	PU	Ord. no.
Conductor support GRP ø 16 mm for air termination conductor ø 8 mm / 50 mm <sup>2</sup>	0.6 m	0.45 m	1	490 003
	0.7 m	0.55 m	1	490 004
	0.9 m	0.75 m	1	490 005

\*) **Type A (fL)** = fixed conductor /leading

Insulated conductor support, to raise the conductor on flat roofs with round concrete base 25 kg, support plate and clamping frame V2A for ø 8 mm.

Specification	Height	Insulated-length	PU	Ord. no.
Conductor support GRP ø 32 mm for conductor ø 8mm / 50 mm <sup>2</sup>	1.1 m	0.94 m	1	490 007
	1.3 m	1.14 m	1	490 008

**Air termination tips for insulated conductors on request.**

Example of applications:

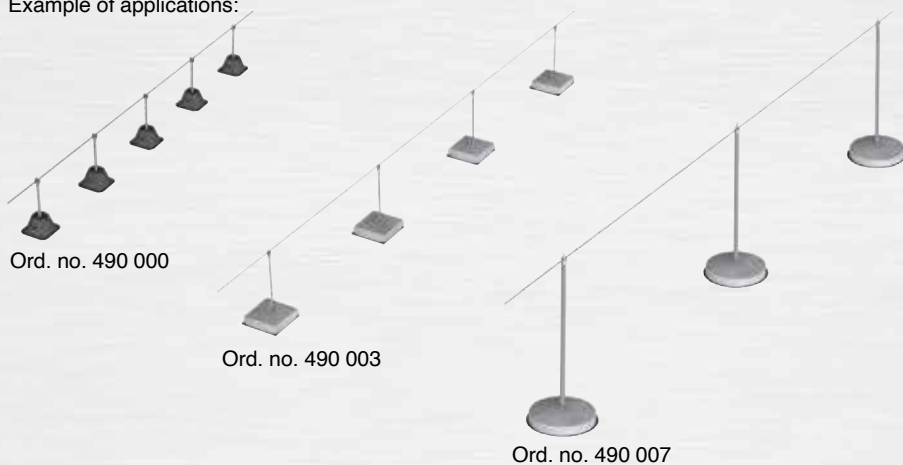

## Insulated conductor support 16-plus



Ord. no. 490 001

## Insulated conductor support 16-plus

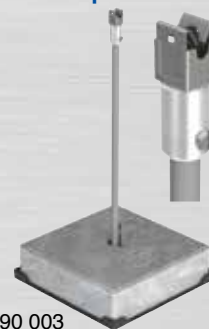

Ord. no. 490 003

## Insulated conductor support 32-stabil



Ord. no. 490 007

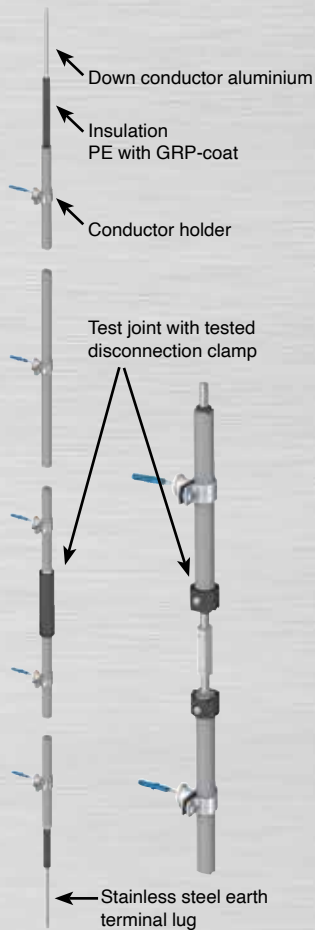

Ord. no. 912 120

## Down conductor-SET



Ord. no. 912 121

## Warning sign



Best.-Nr. 912 119

## Conductor holder

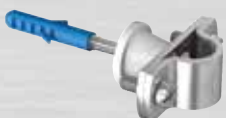

Ord. no. 912 122

## Protection measures against touch voltages

### Complete-SET, total length 3.0 m with test joint (disconnection clamp) and conductor holder

Specification	Fit	PU	Ord. no.
Complete-SET consisting of:		1	912 120
1. Insulation with length of: 3.0 m (PE with GRP-coat in light grey)	ø 22 mm		
2. Interior conductor, length: 4.0 m: Material under disconnection clamp: <b>Stainless steel V4A</b> Material over disconnection clamp: <b>Aluminium</b>	ø 10 mm ø 10 mm		
3. Tested disconnection clamp			
4. Conductor holder (5 pc.)	ø 22 mm		

### Down conductor-SET, total length 3.0 m (without disconnection clamp)

Specification	Fit	PU	Ord. no.
Consisting of:		1	912 121
1. Length of insulation: 3.0 m (PE with GRP-coat in light grey)	ø 22 mm		
2. Interior conductor, <b>stainless steel V4A</b> , length: 4.0 m	ø 10 mm		

### Warning sign, as protection measure against touch and step voltages of persons according to EN 62305-3.; weather proof and UV resistance. Text German.

Specification	Fixing	PU	Ord. no.
Alu Dibond (DIN A5; 148 mm x 210 mm x 3 mm)	4 x ø 5.5 mm	1	912 119

With company logo imprint upon request. Price upon request.

### Conductor holder

Specification	Fit	PU	Ord. no.
<b>Stainless steel V2A</b> , with spacer (h= 20 mm), screw and dowel.	ø 22 mm	1	912 122





# HVC-protected

High voltage resistant conductor

HVC-50

HVC-85

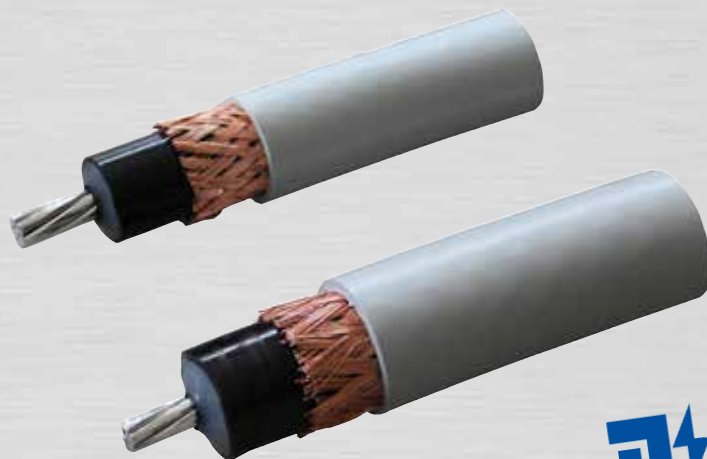

**JIP**  
*Innovation:*

Regular insulation test  
for HVC-50 and HVC-85

Please also ask for additional informations:





## Installation examples

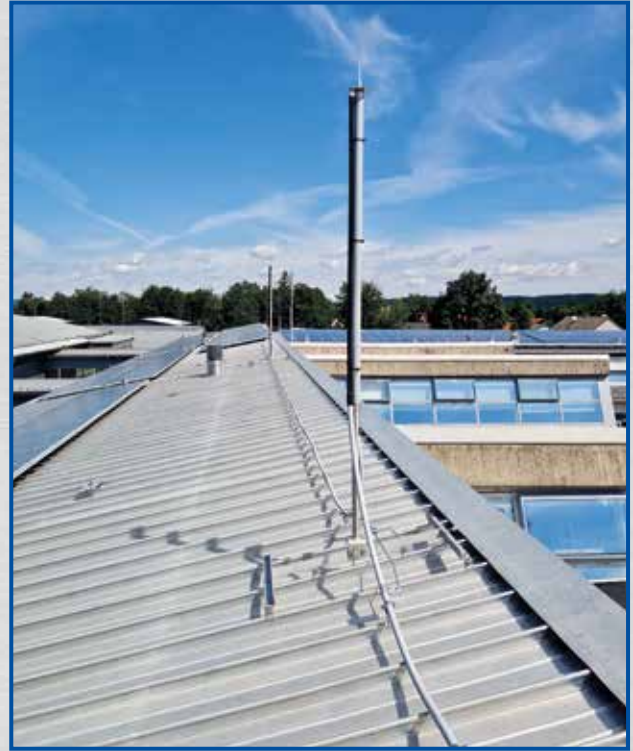



## HVC-50 **HVC-protected**

### Benefits of the HVC-50 conductor:

- Significantly reduced installation work and time.
- The required equipotential bonding is provided by the integrated shield braid in the conductor – no separate conductor is needed.
- Mechanical and chemical protection by light grey, UV-resistant protective jacket.
- Equivalent separation distance “s” = **0.50 m** in air.
- No additional separation distances must be observed in the base area.

Installation is carried out in accordance with the installation instructions.

### Design and technical data:

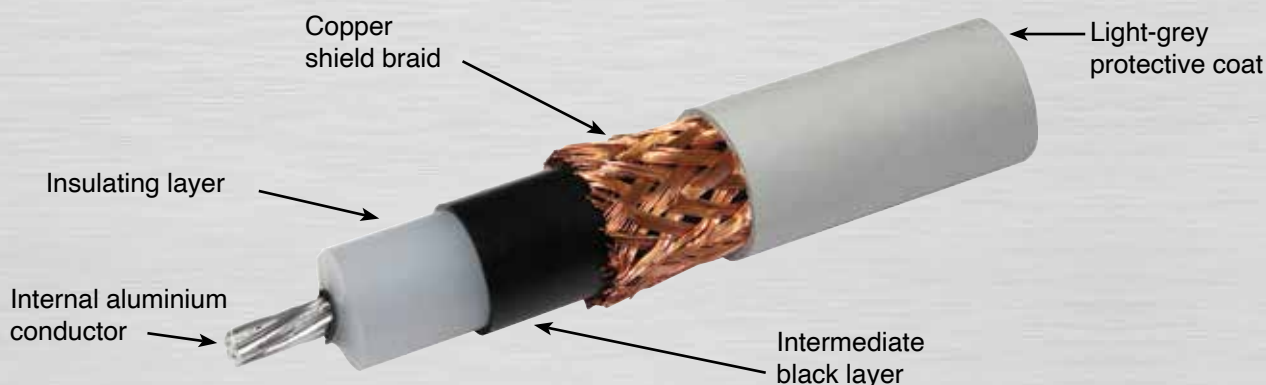

Equivalent separation distance “s” - air	≤ 500 mm
Equivalent separation distance “s” - solid material	≤ 1000 mm
Outer diameter	23 mm (± 0.5 mm)
Minimum bending radius	250 mm
Ambient temperature during installation	> 0°C
Permanent temperature range	-20°C to +70°C
Max. tensile load	1500 N
Weight	ca. 0.635 kg/m
Cross section of stranded internal aluminium conductor	28 mm <sup>2</sup> / aluminium
Cross section of shield braid	16 mm <sup>2</sup> / copper
Fire load	3.2 kWh/m
Weatherproof and UV-resistant	yes

### Maximal conductor length:

Class of LPS	Max. lightning current	No. of down conductors	Max. conductor length *)
I	200 kA	1	--
		2	12 m
		3	18 m
II	150 kA	1	8 m
		2	16 m
		3	25 m
III + IV	100 kA	1	12 m
		2	25 m
		3	37 m

\*) for "s" = 0.50 m in air



## HVC-50 conductor **HVC-protected**

### HVC-50 conductor

Specification	Fit	ca. Weight/m	PU.	Order no.
Length 25 m as a bunch	ø 23 mm	0.635 kg	1	650 001
Length 50 m on a non-returnable reel	ø 23 mm	0.635 kg	1	650 002
Length 100 m on a non-returnable reel	ø 23 mm	0.635 kg	1	650 003

#### Technical data:

Equivalent separation distance "s" - air	≤ 500 mm
Equivalent separation distance "s" - solid material	≤ 1000 mm
Outer diameter	23 mm (± 0.5 mm)
Minimum bending radius	250 mm
Ambient temperature during installation	> 0°C
Permanent temperature range	-20°C to +70°C
Max. tensile load	1500 N
Weight	ca. 0.635 kg/m
Cross section of stranded internal aluminium conductor	28 mm <sup>2</sup> / aluminium
Cross section of shield braid	16 mm <sup>2</sup> / copper
Fire load	3.2 kWh/m
Weatherproof and UV-resistant	yes

List of maximal conductor lengths (while "s" = 0.50 in air) on page 149

### Head-unit



Order no. 651 101

### Head-unit for HVC-50 conductor

**Head-unit**, for **HVC-50** conductor, incl. a complete installation set consisting of 2 heat-shrink-tubings, ferrule, washer and springwasher.

Specification	Connection	PU	Order no.
Aluminium - for exterior pole installation	Hex bolt <b>V2A</b> M10 x 20 mm with a spring washer	1	651 100
Aluminium - for interior pole installation	Threaded bolt <b>V2A</b>	1	651 101
Aluminium - for spanning objects incl. multi-clamp <b>V2A</b>	Threaded bolt <b>V2A</b>	1	651 102
Aluminium - for connection to the attic	Threaded bolt <b>V2A</b> ø 10 x 105 mm	1	651 103

Head-unit made of **stainless steel V2A** on request!

Application examples:



Head-unit  
order no. 651 100 +  
terminal plate  
order no. 632 400  
(see page 167)



Head-unit  
order no. 651 101



Head-unit  
order no. 651 102

### Spare parts, for head-unit

Specification	Fit	Length	PU	Order no.
Ferrule <b>copper/tinned</b>	ø 7 mm	30 mm	10	601 110
Heat-shrink-tubing with glue	ø 32 mm	100 mm	10	651 111



## HVC-50 incl. installed head-unit

**HVC-50 conductor**, cut to length with installed head-unit. Including base unit **aluminium** for self-assembly. Minimum length of **HVC-50** conductor: 5.0 m.

Specification of head-unit (page 150)	Order no. 5.0 m	Order no. xx m
<b>Aluminium</b> - for exterior pole installation	651 100-5	651 100-xx
<b>Aluminium</b> - for interior pole installation	651 101-5	651 101-xx
<b>Aluminium</b> - for spanning objekts incl. multi-clamp <b>V2A</b>	651 102-5	651 102-xx

Head-unit made of **stainless steel V2A** on request!

The last digits of the order no. (**xx**) indicate the overall conductor length.

Order example: 651 100-10

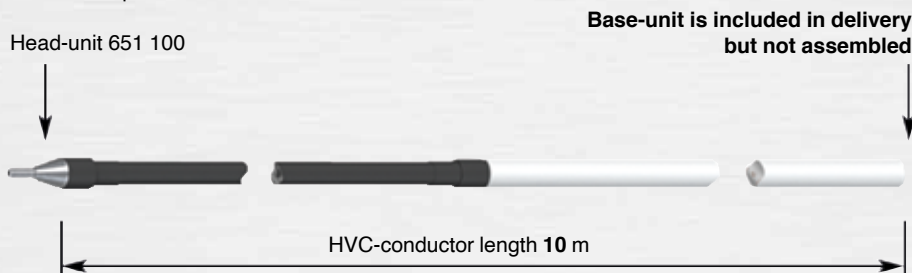

## Base-unit for HVC-50 conductor

**Base-unit**, for **HVC-50** conductor, incl. terminal bolt  $\varnothing$  10 mm made of **stainless steel V2A** and a complete installation set consisting of a heat-shrink-tubing, contact sheet and a ferrule.

Specification	Fit	Length	PU	Order no.
<b>Aluminium</b>	$\varnothing$ 10 mm	70 mm	1	651 200

Base-unit made of **stainless steel V2A** on request

Application example:



Base-unit  
order no. 651 200 +  
Vario-clamp  
order no. 910 579

## Spare parts, for base-unit

Specification	Fit	Length	PU	Order no.
Ferrule <b>copper</b> /tinned	$\varnothing$ 7 mm	30 mm	10	601 110
Heat-shrink-tubing with glue	$\varnothing$ 39 mm	125 mm	10	601 111
Contact sheet <b>stainless steel V2A</b>	$\varnothing$ 7 mm		5	651 113

**Extreme seuling tape for HVC head- and base-units.**  
as an alternative product to head-shrink-tubing 601 111 and 651 111

Specification	Width	Length	PU	Order no.
Acrylate adhesive tape on ionemer carrier	50 mm	33 m	1	640 030

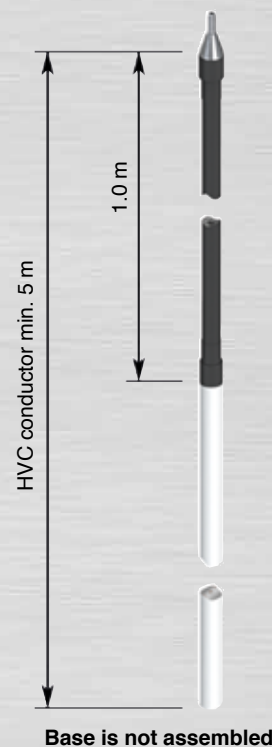

## Base-unit



Order no. 651 200

## Extreme seuling tape



Order no. 640 030



## Installation examples







## HVC-85 **HVC-protected**

### Benefits of the HVC-85 conductor:

- Significantly reduced installation work and time.
- The required equipotential bonding is provided by the integrated shield braid in the conductor – no separate conductor is needed.
- Mechanical and chemical protection by light grey, UV-resistant protective jacket.
- Equivalent separation distance “s” = **0.85 m** in air.
- No additional separation distances must be observed in the base area.

Installation is carried out in accordance with the installation instructions.

### Design and technical data:

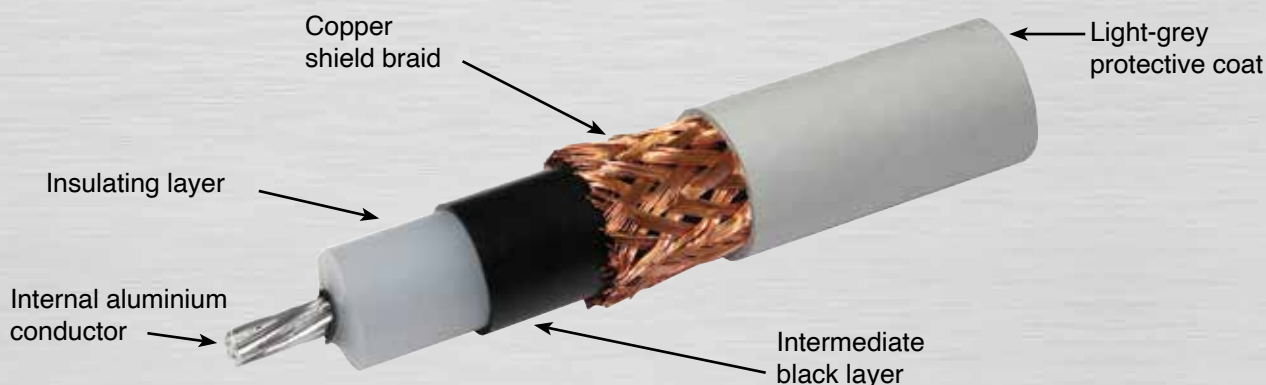

Equivalent separation distance “s” - air	≤ 850 mm
Equivalent separation distance “s” - solid material	≤ 1700 mm
Outer diameter	28 mm (± 0.5 mm)
Minimum bending radius	250 mm
Ambient temperature during installation	> 0°C
Permanent temperature range	-20°C to +70°C
Max. tensile load	1500 N
Weight	ca. 0.918 kg/m
Cross section of stranded internal aluminium conductor	28 mm <sup>2</sup> / aluminium
Cross section of shield braid	16 mm <sup>2</sup> / copper
Fire load	5.83 kWh/m
Weatherproof and UV-resistant	yes

### Maximal conductor length:

Class of LPS	Max. lightning current	No. of down conductors	Max. conductor length *)
I	200 kA	1	--
		2	21 m
		3	32 m
II	150 kA	1	14 m
		2	28 m
		3	42 m
III + IV	100 kA	1	21 m
		2	42 m
		3	64 m

\*) for "s" = 0.85 m in air



## HVC-85



## Head-unit



Order no. 601 101

HVC-Conductor

## HVC-85 conductor **HVC-protected**

### HVC-85 conductor

Specification	Fit	ca. Weight/m	PU.	Order no.
Length 25 m as a bunch	ø 28 mm	0.918 kg	1	600 001
Length 50 m on a non-returnable reel	ø 28 mm	0.918 kg	1	600 002
Length 100 m on a non-returnable reel	ø 28 mm	0.918 kg	1	600 003

#### Technical data:

Equivalent separation distance "s" - air	≤ 850 mm
Equivalent separation distance "s" - solid material	≤ 1700 mm
Outer diameter	28.0 mm (± 1.0 mm)
Minimum bending radius	250 mm
Ambient temperature during installation	> 0°C
Permanent temperature range	-20°C to +70°C
Max. tensile load	1500 N
Weight	ca. 0.918 kg/m
Cross section of stranded internal aluminium conductor	28 mm <sup>2</sup> / aluminium
Cross section of shield braid	16 mm <sup>2</sup> / copper
Fire load	5.83 kWh/m
Weatherproof and UV-resistant	yes

List of maximal conductor lengths (while "s" = 0.85 in air) on page 155

## Head-unit

**Head-unit**, for **HVC-85** conductor, incl. a complete installation set consisting of 2 heat-shrink-tubings, ferrule, washer and springwasher.

Specification	Connection	PU	Order no.
Aluminium - for exterior pole installation	Hex bolt <b>V2A</b> M10 x 20 mm with a spring washer	1	601 100
Aluminium - for interior pole installation	Threaded bolt <b>V2A</b>	1	601 101
Aluminium - for spanning objects incl. multi-clamp <b>V2A</b>	Threaded bolt <b>V2A</b>	1	601 102
Aluminium - for connection to the attic	Threaded bolt <b>V2A</b> ø 10 x 105 mm	1	601 103

Head-unit made of **stainless steel V2A** on request!

Application examples:



Head-unit  
order no. 601 100 +  
terminal plate  
order no. 632 400  
(see page 167)



Head-unit  
order no. 601 101



Head-unit  
order no. 601 102

### Spare parts, for head-unit

Specification	Fit	Length	PU	Order no.
Ferrule <b>copper</b> /tinned	ø 7 mm	30 mm	10	601 110
Heat-shrink-tubing with glue	ø 39 mm	125 mm	10	601 111



## HVC-85 conductor incl. installed head-unit

**HVC-85 conductor**, cut to length with installed head-unit. Including base unit **aluminium** for self-assembly. Minimum length of **HVC-85** conductor: 5.0 m.

Specification of head-unit (page 154)	Order no. 5.0 m	Order no. xx m
<b>Aluminium</b> - for exterior pole installation	601 100-5	601 100-xx
<b>Aluminium</b> - for interior pole installation	601 101-5	601 101-xx
<b>Aluminium</b> - for spanning objekts incl. multi-clamp <b>V2A</b>	601 102-5	601 102-xx

Head-unit made of **stainless steel V2A** on request!

The last digits of the order no. (**xx**) indicate the overall conductor length.

Order example: 601 100-10



## Base-unit

**Base-unit**, for **HVC-85** conductor, incl. terminal bolt  $\varnothing$  10 mm made of **stainless steel V2A** and a complete installation set consisting of a heat-shrink-tubing, contact sheet and a ferrule.

Specification	Fit	Length	PU	Order no.
<b>Aluminium</b>	$\varnothing$ 10 mm	70 mm	1	601 200

Base-unit made of **stainless steel V2A** on request

Application example:

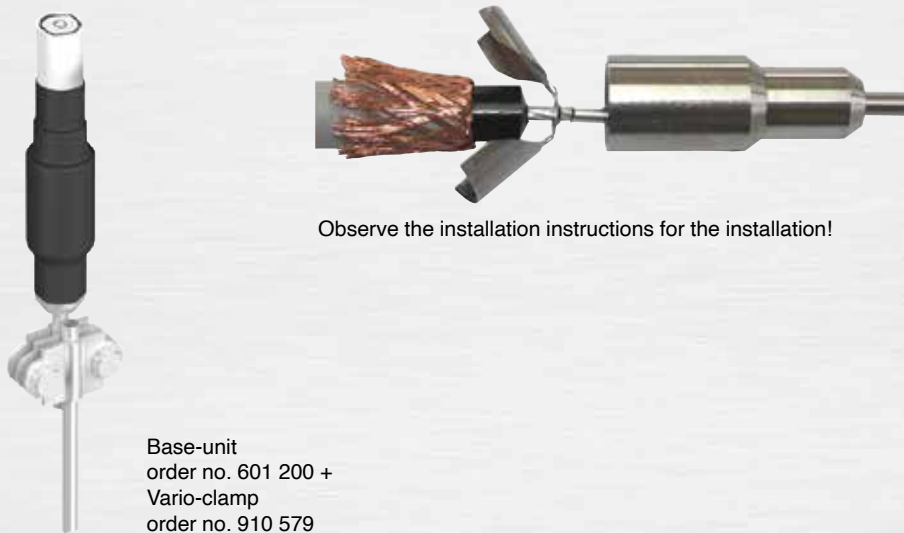

Base-unit  
order no. 601 200 +  
Vario-clamp  
order no. 910 579

## Spare parts, for base-unit

Specification	Fit	Length	PU	Order no.
Ferrule <b>copper</b> /tinned	$\varnothing$ 7 mm	30 mm	10	601 110
Heat-shrink-tubing with glue	$\varnothing$ 52 mm	150 mm	10	601 112
Contact sheet <b>stainless steel V2A</b>	$\varnothing$ 7 mm		5	601 113

## Extreme seuling tape for HVC head- and base-units.

as an alternative product to head-shrink-tubing 601 111 and 601 112

Specification	Width	Length	PU	Order no.
Acrylate adhesive tape on ionemer carrier	50 mm	33 m	1	640 030

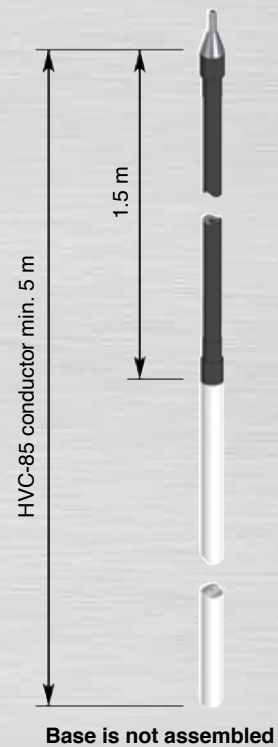

## Base-unit



Order no. 601 200

## Extreme seuling tape



Order no. 640 030



## Air termination pole for HVC-50 and HVC-85

Free-standing up to a height of 8.0 m  
for HVC-interior pole installation

### Air termination pole SET for HVC-conductor, free-standing

Specification according to IEC / TS 62561-8 / EN 62561-2:

<b>Air termination tip:</b> Aluminium	0.4 m above air termination conductor height
<b>Insulated support:</b> GRP	1.7 m
<b>Stand pipe length:</b> Stainless steel V2A	variable, with opening to insert the HVC conductor

Including air termination pole base frame, concrete bases and support plates

Total height	Pole parts	Pole base frame order no.	Concrete base order no.	Footprint	Order no.
3.0 m	1-part	499 000	4 x 499 100	0.65 x 0.65 m	632 000
4.0 m	1-part	499 005	3 x 103 101	1.33 x 1.28 m	632 001
5.0 m	1-part	499 005	3 x 103 118	1.37 x 1.32 m	632 002
6.0 m	2-part	499 006	6 x 103 101	1.87 x 1.66 m	632 003
7.0 m	2-part	499 006	6 x 103 110	1.87 x 1.66 m	632 004
8.0 m	2-part	499 007	10 x 103 110	1.90 x 1.75 m	632 005

### Wind speed according to Eurocode:

Air termination pole height	Order no.	Wind speed	
		Static safety factor 1.0	Static safety factor 1.5
up to 3.00 m	632 000	150 km/h	123 km/h
up to 4.00 m	632 001	171 km/h	140 km/h
up to 5.00 m	632 002	137 km/h	111 km/h
up to 6.00 m	632 003	156 km/h	127 km/h
up to 7.00 m	632 004	143 km/h	117 km/h
up to 8.00 m	632 005	157 km/h	128 km/h

Design of air termination pole (application example):

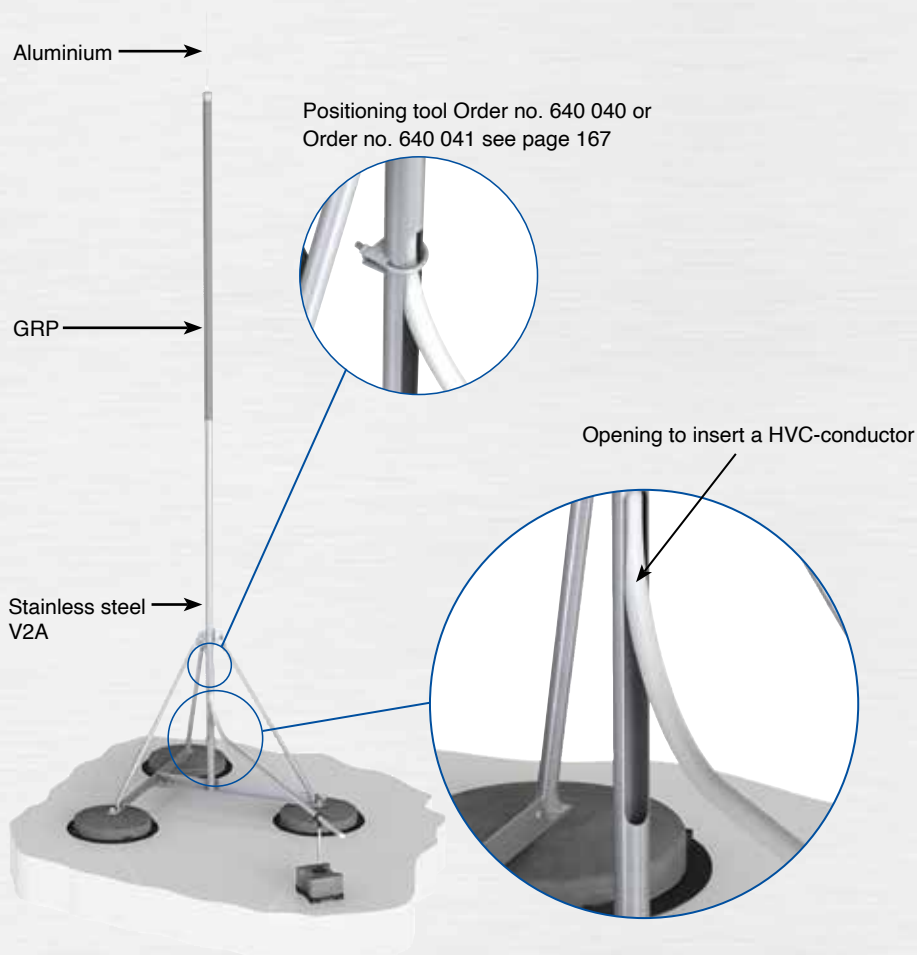

Order no. 632 000

Order no. 632 003

Air termination pole order no. 632 001 + Insulated support order no. 624 011 (page 163)



## Air termination pole for HVC-50 and HVC-85

Free-standing up to a height of 8.0 m, with telescopic termination rod for HVC-exterior pole installation resp. meshed systems

### Benefits:

- Transport length of the pole parts max. 2.8 m.
- Telescopic air termination rod in aluminium.
- Enormous saving of HVC conductor lengths for meshed systems.
- Significantly less time required for the installation.
- Separation distances better manageable due to shorter HVC-conductor lengths.

Air termination pole SET for HVC-conductor, free-standing with telescopic air termination rod.

Specification according to IEC / TS 62561-8 / EN 62561-2:

**Air termination rod:** Aluminium telescopic, variable length  
**Insulated support:** GRP 1.7 m  
**Stand pipe length:** Stainless steel V2A variable

Including air termination pole base frame, concrete bases and support plates

Total height	Height HVC-conductor connection	Pole base frame order no.	Concrete base order no.	Footprint	Order no.
NEW 4.0 m	1.8 m	499 000	8 x 499 101	0.65 x 0.65 m	632 101
NEW 5.0 m	2.7 m	499 005	3 x 103 118	1.37 x 1.32 m	632 102
NEW 6.0 m	3.3 m	499 006	6 x 103 101	1.87 x 1.66 m	632 103
NEW 7.0 m	3.3 m	499 006	6 x 103 118	1.91 x 1.71 m	632 104
NEW 8.0 m	4.3 m	499 006	6 x 103 118	1.91 x 1.71 m	632 105

### Wind speed according to Eurocode:

Air termination pole height	Order no.	Wind speed	
		Static safety factor 1.0	Static safety factor 1.5
up to 4.00 m	632 101	157 km/h	128 km/h
up to 5.00 m	632 102	141 km/h	115 km/h
up to 6.00 m	632 103	148 km/h	121 km/h
up to 7.00 m	632 104	163 km/h	133 km/h
up to 8.00 m	632 105	132 km/h	108 km/h

Design of air termination pole (application example):

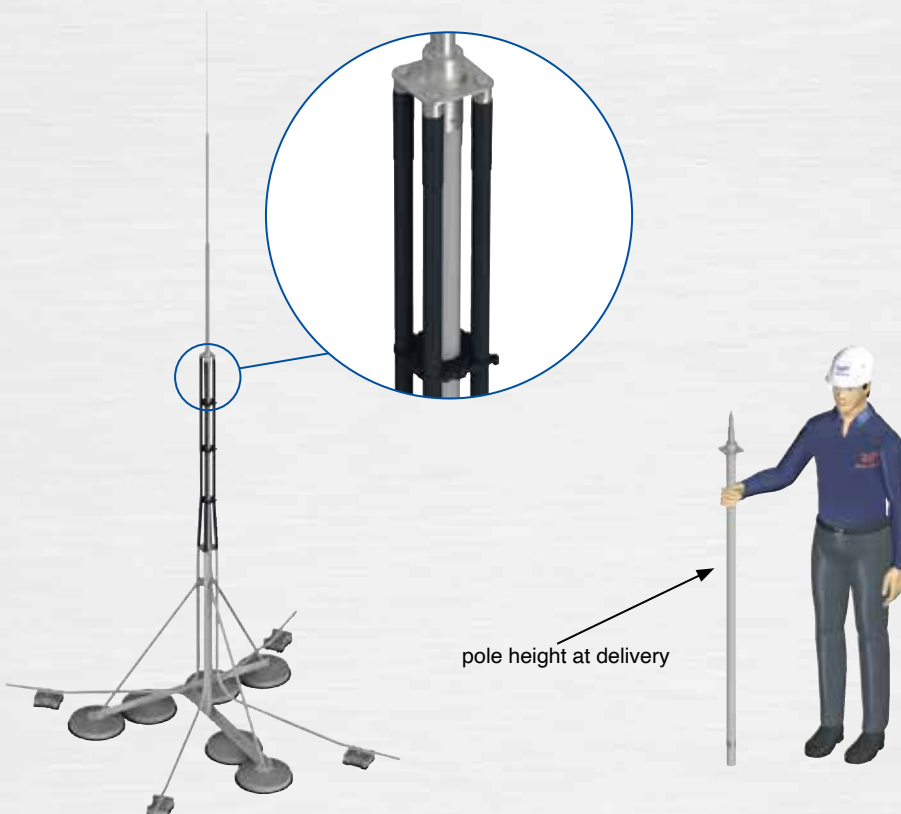

## Air termination pole, free-standing with telescopic termination rod

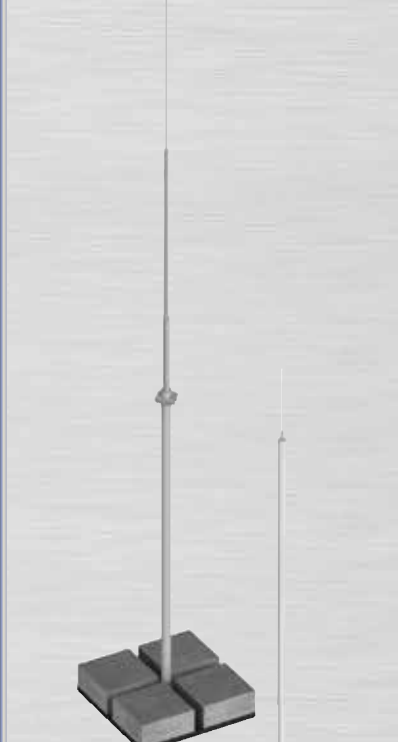

Order no. 632 101



Order no. 632 103

HVC-Conductor



Order no. 632 200

## Wall fastener

### Type A



Order no. 490 550

### Type B



Order no. 490 560

### Type C

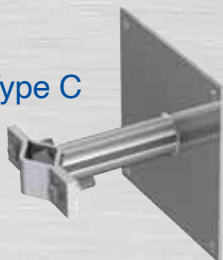

Order no. 490 570

## Fixing anchors



Order no. 490 548

## Air termination pole fastener



Ord. no. 490 540

## Air termination pole for wall mounting

unsupported up to a height of 8.0 m  
for HVC-interior pole installation

### Air termination pole for HVC-conductor, self-supporting

Specification according to IEC / TS 62561-8 / EN 62561-2:

**Air termination tip:** Aluminium 0.4 m above air termination conductor height  
**Insulated support:** GRP 1.7 m  
**Stand pipe length:** Stainless steel V2A variable

Total height	Pole parts	Necessary wall fastener	Order no.
3.0 m	1-part	2x Type A	632 200
4.0 m	1-part	2x Type A	632 201
5.0 m	1-part	2x Type B	632 202
6.0 m	2-part	2x Type C	632 203
7.0 m	2-part	2x Type C	632 204
8.0 m	2-part	2x Type C	632 205

Additional pole fasteners e.g. Rafter fastener see page 138

**Wall fastener** for poles with HVC-conductor up to max. height of 4.0 m and  $\varnothing$  42 mm.  
Hole pattern for rivet and screw mounting and 2 x  $\varnothing$  10.5 mm.

Specification	Wall distance	PU	Ord. no.
Completely in stainless steel V2A for $\varnothing$ 42 mm pole clamp with 2 x screws M10 spring lock washer and nut V2A	150 mm	1	490 550
	200 mm	1	490 551
	250 mm	1	490 552
	300 mm	1	490 553

**Wall fastener** for poles with HVC conductor up to max. height of 5.0 m and  $\varnothing$  42 mm.  
Hole pattern 4x  $\varnothing$  10.5 mm.

Specification	Wall distance	PU	Ord. no.
Completely in stainless steel V2A for $\varnothing$ 42 mm pole clamp with 2 x screws M10 spring lock washer and nut V2A mounting plate V2A: 200 x 200 x 8 mm hole pattern mounting plate: $\square$ 170 x 170 mm	150 mm	1	490 560
	200 mm	1	490 561
	250 mm	1	490 562
	300 mm	1	490 563

**Wall fastener** for poles with HVC conductor up to max. height of 8.0 m and  $\varnothing$  60 mm.  
Hole pattern 4 x  $\varnothing$  12.5 mm.

Specification	Wall distance	PU	Ord. no.
Completely in stainless steel V2A for $\varnothing$ 60 mm pole clamp with 2 x screws M16 spring lock washer and nut V2A mounting plate V2A: 300 x 300 x 8 mm hole pattern mounting plate: $\square$ 260 x 260 mm	150 mm	1	490 570
	200 mm	1	490 571
	250 mm	1	490 572
	300 mm	1	490 573

**Fixing anchors**, stainless steel V4A for wall fastener on concrete walls.

Specification	PU	Ord. no.
M10 for wall fastener Type A and Type B	1	490 548
M12 for wall fastener Type C	1	490 549

**Air termination pole fastener** for poles with HVC-conductor up to 5.0 m height and  $\varnothing$  42 mm. Tape pipe clamp V2A for clamping range up to 800 mm.

Specification	Wall distance	PU	Ord. no.
Completely in stainless steel V2A for $\varnothing$ 42 mm pipe clamp with 2 x screws M10, spring lock washer and nut in V2A Tape pipe clamp with 2 x screws M8 V2A	150 mm	1	490 540
	200 mm	1	490 541
	250 mm	1	490 542
	300 mm	1	490 543

## Air termination pole for wall mounting

unsupported up to a height of 8.0 m, with telescopic termination rod for HVC-exterior pole installation resp. meshed systems

### Benefits:

- Transport length of the pole parts max. 2.8 m.
- Telescopic air termination rod in aluminium.
- Enormous saving of HVC conductor lengths for meshed systems.
- Significantly less time required for the installation.
- Separation distances better manageable due to shorter HVC-conductor lengths.

Air termination pole for HVC-conductor, unsupported with telescopic termination rod

Specification according to IEC / TS 62561-8 / EN 62561-2:

**Air termination rod:** Aluminium telescopic, variable length  
**Insulated support:** GRP 1.7 m  
**Stand pipe length:** Stainless steel V2A variable

Total height	Height HVC-conductor connection	Necessary wall fastener	Order no.
5.0 m	2.6 m	2x Type B	632 302
6.0 m	3.2 m	2x Type C	632 303
7.0 m	3.2 m	2x Type C	632 304
8.0 m	4.2 m	2x Type C	632 305

NEW  
NEW  
NEW  
NEW

Additional pole fasteners e.g. Rafter fastener see page 138

Wind speed according to Eurocode:

Air termination pole height	Order no.	Wall fastener	FL 1	EL 1	Wind speed	
					Static safety factor 1.0	Static safety factor 1.5
Air termination pole for wall mounting in Stainless steel V2A						
3.0 m	632 200	2x Type A	2.40 m	0.60 m	149 km/h	122 km/h
4.0 m	632 201	2x Type A	3.00 m	1.00 m	149 km/h	122 km/h
5.0 m	632 202	2x Type B	4.30 m	0.70 m	196 km/h	160 km/h
6.0 m	632 203	2x Type C	5.00 m	1.00 m	197 km/h	161 km/h
7.0 m	632 204	2x Type C	6.00 m	1.00 m	198 km/h	162 km/h
8.0 m	632 205	2x Type C	7.00 m	1.00 m	200 km/h	163 km/h
Telescopic air termination pole Aluminium for wall mounting						
up to 5.0 m	632 302	2x Type B	4.30 m	0.70 m	196 km/h	160 km/h
up to 6.0 m	632 303	2x Type C	5.00 m	1.00 m	196 km/h	160 km/h
up to 7.0 m	632 304	2x Type C	6.00 m	1.00 m	176 km/h	144 km/h
up to 8.0 m	632 305	2x Type C	7.00 m	1.00 m	176 km/h	144 km/h

Explanation: Clamping lengths air ter. pole with wall fastener

Example:

3.0 m air ter. pole  
 Order no. 632 200 +  
 2x wall fastener Type A

EL1 = 0.6 m  
 FL1 = 2.4 m

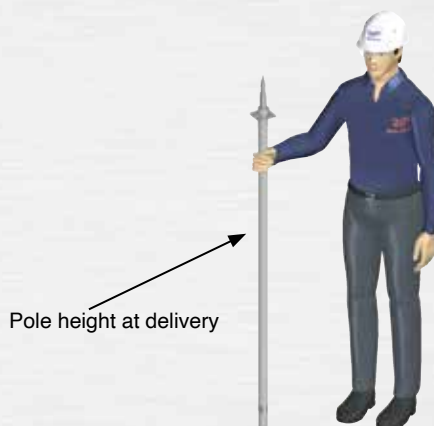
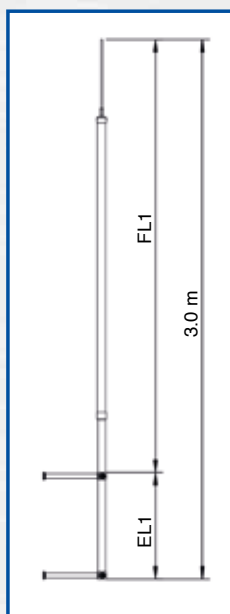

Air termination pole, unsupported with telescopic termination rod



Order no. 632 302



## HVC conductor fastener



Order no. 612 003



Order no. 614 003

## HVC conductor fastener

### HVC-50 conductor fastener

Specification	Fixing	Fit	PU	Order no.
Stainless steel V2A	ø 6.5 mm	ø 23 mm	50	662 003 
Stainless steel V2A	ø 8.5 mm	ø 23 mm	50	662 002
Plastic	ø 6.5 mm	ø 23 mm	50	664 003

### HVC-85 conductor fastener

Specification	Fixing	Fit	PU	Order no.
Stainless steel V2A	ø 6.5 mm	ø 28 mm	50	612 003 
Stainless steel V2A	ø 8.5 mm	ø 28 mm	50	612 002
Plastic	ø 6.5 mm	ø 28 mm	50	614 003



Delivery state



Screws in top part are self-retaining

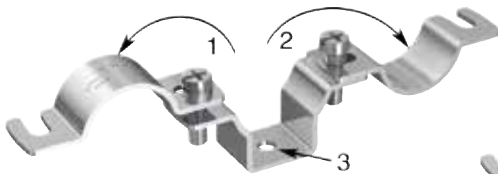

- 1 Open top fastener piece
- 2 Open bottom fastener piece
- 3 Mount conductor fastener

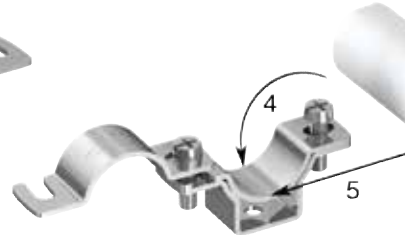

- 4 Swivel back bottom fastener piece
- 5 Insert HVC-conductor into fastener

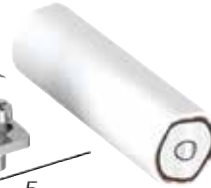

- 6 Close top fastener piece and tighten screws

## HVC conductor fastener



Order no. 612 001



Order no. 614 001

### HVC-50 conductor fastener, with washer, screw and ø 8 mm dowel.

Specification	Conductor height	Fit	PU	Order no.
Stainless steel V2A	18 mm	ø 23 mm	50	662 001 
Plastic	13 mm	ø 23 mm	50	664 001

### HVC-85 conductor fastener, with washer, screw and ø 8 mm dowel.

Specification	Conductor height	Fit	PU	Order no.
Stainless steel V2A	18 mm	ø 28 mm	50	612 001 
Plastic	13 mm	ø 28 mm	50	614 001

## HVC conductor fastener

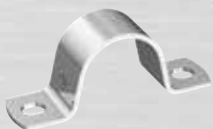

Order no. 612 004

### HVC-50 conductor fastener, for the direct fixing to walls.

Also suitable for external thermal insulation composite systems

Specification	Fixing	Fit	PU	Order no.
Stainless steel V2A	ø 7 x 8.5 mm	ø 23 mm	50	662 004 

### HVC-85 conductor fastener, for the direct fixing to walls.

Also suitable for external thermal insulation composite systems

Specification	Fixing	Fit	PU	Order no.
Stainless steel V2A	ø 7 x 8.5 mm	ø 28 mm	50	612 004 





## Dachleitungsstütze

Roof conductor holder, for flat roofs with **HVC-50** conductor fastener  $\varnothing$  23 mm, including concrete base (H-shape) and base plate

Specification	Concrete block	Fit	PU	Order no.
Stainless steel V2A with concrete block	5.0 kg	$\varnothing$ 23 mm	1	672 000 
Stainless steel V2A with concrete block	7.5 kg	$\varnothing$ 23 mm	1	672 001
Plastic with concrete block	5.0 kg	$\varnothing$ 23 mm	1	674 000
Plastic with concrete block	7.5 kg	$\varnothing$ 23 mm	1	674 001

Roof conductor holder, for flat roofs with **HVC-85** conductor fastener  $\varnothing$  28 mm, including concrete base (H-shape) and base plate

Specification	Concrete block	Fit	PU	Order no.
Stainless steel V2A with concrete block	5.0 kg	$\varnothing$ 28 mm	1	622 000 
Stainless steel V2A with concrete block	7.5 kg	$\varnothing$ 28 mm	1	622 001
Plastic with concrete block	5.0 kg	$\varnothing$ 28 mm	1	624 000
Plastic with concrete block	7.5 kg	$\varnothing$ 28 mm	1	624 001

### Benefits:

- Laying the **HVC** conductor on flat roofs without additional screwing effort through clip fastening.
- Easier handling due to the low weight of the individual holders.

PR-ÖKO 2 Adapter, for **HVC-50** conductor, suitable for 1kg roof conductor holder Order no. 111 630

Specification	Fit	PU	Order no.
Plastic screwed	$\varnothing$ 23 mm	50	674 003

PR-ÖKO 2 Adapter, for **HVC-85** conductor, suitable for 1kg roof conductor holder Order no. 111 630

Specification	Fit	PU	Order no.
Plastic screwed	$\varnothing$ 28 mm	50	624 003

**Note:** Roof conductor holder PR-ÖKO 2 (Order no. 111 630; page 81) must be ordered separately.

Roof conductor holder, for universal use with **HVC-50** conductor fastener  $\varnothing$  23 mm.

Specification	Length	Fit	PU	Order no.
Stainless steel V2A	210 mm	$\varnothing$ 23 mm	1	662 080 
Stainless steel V2A	280 mm	$\varnothing$ 23 mm	1	662 081
Stainless steel V2A	410 mm	$\varnothing$ 23 mm	1	662 082

Roof conductor holder, for universal use with **HVC-85** conductor fastener  $\varnothing$  28 mm.

Specification	Length	Fit	PU	Order no.
Stainless steel V2A	210 mm	$\varnothing$ 28 mm	1	612 080 
Stainless steel V2A	280 mm	$\varnothing$ 28 mm	1	612 081
Stainless steel V2A	410 mm	$\varnothing$ 28 mm	1	612 082

## Roof conductor holder

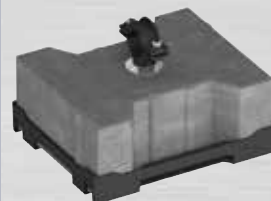

Order no. 624 000

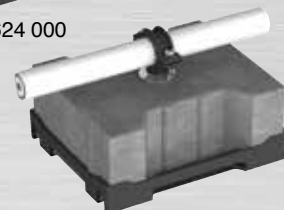

Application example

## PR-ÖKO 2 Adapter



Order no. 624 003

Application example

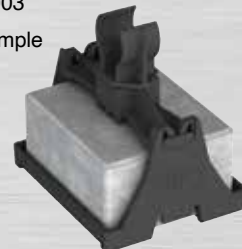

## Roof conductor holder (J&P-patent)



Order no. 612 080



## Roof conductor holder for Kalzip



Order no. 614 060

## Roof conductor holder for RIB-ROOF 500



Order no. 614 070

## Roof conductor holder for standing seam



Order no. 612 100

Order no. 614 100

## Roof conductor holder for synthetic roofing membranes and bitumen roofs

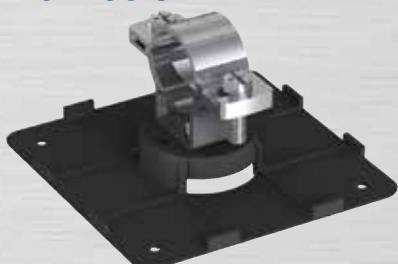

Order no. 612 090

162

## Roof conductor holder

Roof conductor holder, for Kalzip with **HVC-50** conductor fastener  $\varnothing$  23 mm.

Specification		Fit	PU	Order no.
<b>Support</b>	<b>Fastener</b>			
Stainless steel V2A	Stainless steel V2A	$\varnothing$ 23 mm	25	662 060
Stainless steel V2A	Plastic	$\varnothing$ 23 mm	25	664 060



Roof conductor holder, for Kalzip with **HVC-85** conductor fastener  $\varnothing$  28 mm.

Specification		Fit	PU	Order no.
<b>Support</b>	<b>Fastener</b>			
Stainless steel V2A	Stainless steel V2A	$\varnothing$ 28 mm	25	612 060
Stainless steel V2A	Plastic	$\varnothing$ 28 mm	25	614 060



Roof conductor holder, for RIB-ROOF 500 with **HVC-50** conductor fastener  $\varnothing$  23 mm.

Specification		Fit	PU	Order no.
<b>Support</b>	<b>Fastener</b>			
Stainless steel V2A	Stainless steel V2A	$\varnothing$ 23 mm	25	662 070
Stainless steel V2A	Plastic	$\varnothing$ 23 mm	25	664 070



Roof conductor holder, for RIB-ROOF 500 with **HVC-85** conductor fastener  $\varnothing$  28 mm.

Specification		Fit	PU	Order no.
<b>Support</b>	<b>Fastener</b>			
Stainless steel V2A	Stainless steel V2A	$\varnothing$ 28 mm	25	612 070
Stainless steel V2A	Plastic	$\varnothing$ 28 mm	25	614 070



Roof conductor holder, for standing seam with **HVC-50** conductor fastener  $\varnothing$  23 mm.

Specification		Fit	PU	Order no.
<b>Stütze</b>	<b>Halter</b>			
Stainless steel V2A	Stainless steel V2A	$\varnothing$ 23 mm	25	662 100
Stainless steel V2A	Plastic	$\varnothing$ 23 mm	25	664 100



Roof conductor holder, for standing seam with **HVC-85** conductor fastener  $\varnothing$  28 mm.

Specification		Fit	PU	Order no.
<b>Support</b>	<b>Fastener</b>			
Stainless steel V2A	Stainless steel V2A	$\varnothing$ 28 mm	25	612 100
Stainless steel V2A	Plastic	$\varnothing$ 28 mm	25	614 100



Roof conductor holder with **HVC-50** conductor fastener. For synthetic roofing membranes and bitumen roofs. To be fixed onto synthetic roofing membranes with weldable fastening strips; glued directly onto bitumen roofs.

Specification	Fastener	Conductor height	Fit	PU	Order no.
Support					
Plastic HD-PE	Stainless steel V2A	28 mm	$\varnothing$ 23 mm	50	662 090



Roof conductor holder with **HVC-85** conductor fastener. For synthetic roofing membranes and bitumen roofs. To be fixed onto synthetic roofing membranes with weldable fastening strips; glued directly onto bitumen roofs.

Specification	Fastener	Conductor height	Fit	PU	Order no.
Support					
Plastic HD-PE	Stainless steel V2A	28 mm	$\varnothing$ 28 mm	50	612 090





## Conductor support

**Conductor support**, to increase the height of the **HVC-50** conductor on flat roofs.  
Incl. concrete base, H-shaped 7.5 kg, support plate and plastic conductor holder ø 23 mm.

Specification	Conductor height	PU	Order no.
Conductor support GRP ø 16 mm (SET)	300 mm	1	674 010
Conductor support GRP ø 16 mm (SET)	400 mm	1	674 011

**Conductor support**, to increase the height of the **HVC-85** conductor on flat roofs.  
Incl. concrete base, H-shaped 7.5 kg, support plate and plastic conductor holder ø 28 mm.

Specification	Conductor height	PU	Order no.
Conductor support GRP ø 16 mm (SET)	300 mm	1	624 010
Conductor support GRP ø 16 mm (SET)	400 mm	1	624 011

**Conductor support**, to increase the height of the **HVC-50** conductor on flat roofs. Incl. concrete base 16kg with JP-wedge technology, support plate & plastic conductor holder ø 23 mm.

Specification	Conductor height	PU	Order no.
Conductor support GRP ø 16 mm (SET)	500 mm	1	674 020
Conductor support GRP ø 16 mm (SET)	600 mm	1	674 021
Conductor support GRP ø 16 mm (SET)	700 mm	1	674 022

**Conductor support**, to increase the height of the **HVC-85** conductor on flat roofs. Incl. concrete base 16kg with JP-wedge technology, support plate & plastic conductor holder ø 28 mm.

Specification	Conductor height	PU	Order no.
Conductor support GRP ø 16 mm (SET)	500 mm	1	624 020
Conductor support GRP ø 16 mm (SET)	600 mm	1	624 021
Conductor support GRP ø 16 mm (SET)	700 mm	1	624 022

Application examples:

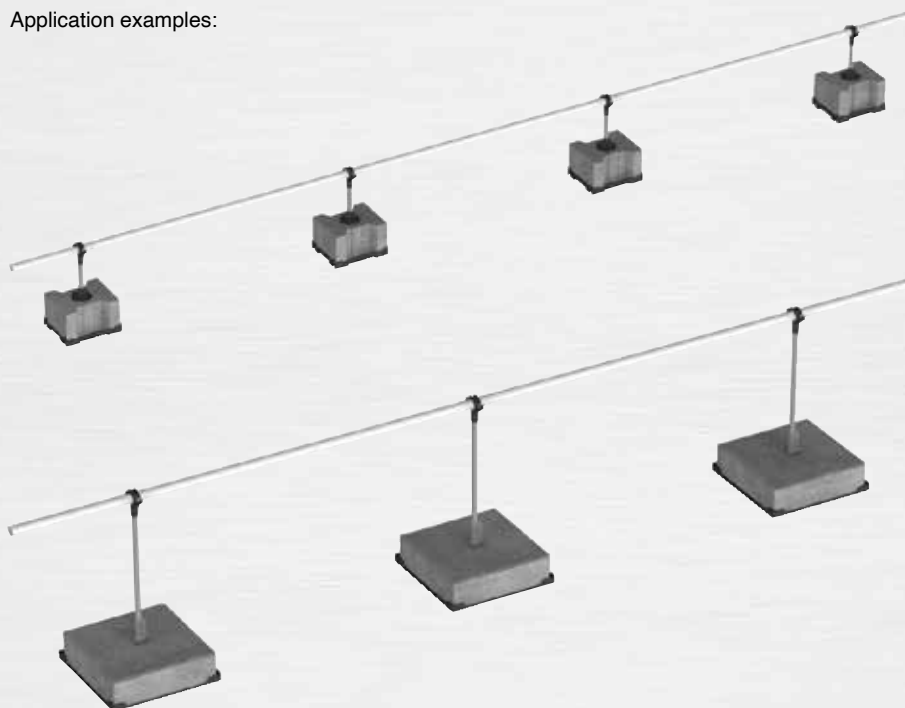

## Conductor support



Order no. 624 010

## Conductor support



Order no. 624 020



## Fixing bush



Order no. 622 005



Order no. 624 005

## Mounting plate and angle bracket



Order no. 614 010



Order no. 614 011

## Terminal clamp, heavy-duty type



Order no. 612 021

## Beam clip



Order no. 624 007

Order no. 624 006

## Mounting clamps

Fixing bush for **16plus+**, with **HVC-50** conductor fastener  $\varnothing$  23 mm for fixing to the solid rod GRP  $\varnothing$  16 mm.

Specification	Length	PU	Order no.
Fixing bush <b>aluminium</b> , for GRP $\varnothing$ 16 mm; with <b>HVC-50</b> conductor fastener, <b>stainless steel V2A</b>	40 mm	25	672 005
with <b>HVC-50</b> conductor fastener, Plastic	40 mm	25	674 005

Fixing bush for **16plus+**, with **HVC-85** conductor fastener  $\varnothing$  28 mm for fixing to the solid rod GRP  $\varnothing$  16 mm.

Specification	Length	PU	Order no.
Fixing bush <b>aluminium</b> , for GRP $\varnothing$ 16 mm; with <b>HVC-85</b> conductor fastener, <b>stainless steel V2A</b>	40 mm	25	622 005
with <b>HVC-85</b> conductor fastener, Plastic	40 mm	25	624 005

Combination possibilities system **16plus+** please see page 142.

Mounting plate and angle bracket, to mount the **HVC-50** conductor  $\varnothing$  23 mm on walls and metal sheets.

Specification	HVC-50 conductor fastener	PU	Order no.
Mounting plate <b>stainless steel V2A</b>	Plastic	25	664 010
Angle bracket <b>stainless steel V2A</b>	Plastic	25	664 011
Mounting plate <b>stainless steel V2A</b>	<b>Stainless steel V2A</b>	25	662 010
Angle bracket <b>stainless steel V2A</b>	<b>Stainless steel V2A</b>	25	662 011

Mounting plate and angle bracket, to mount the **HVC-85** conductor  $\varnothing$  28 mm on walls and metal sheets.

Specification	HVC-85 conductor fastener	PU	Order no.
Mounting plate <b>stainless steel V2A</b>	Plastic	25	614 010
Angle bracket <b>stainless steel V2A</b>	Plastic	25	614 011
Mounting plate <b>stainless steel V2A</b>	<b>Stainless steel V2A</b>	25	612 010
Angle bracket <b>stainless steel V2A</b>	<b>Stainless steel V2A</b>	25	612 011

Terminal clamp, heavy-duty type, to mount the **HVC-50** conductor to steel constructions or railings with fixing bush, **aluminium**, and fastener, **stainless steel V2A**  $\varnothing$  23 mm.

Specification	Clamping area	Fit	PU	Order no.
<b>Stainless steel V2A</b>	5 - 19 mm	$\varnothing$ 23 mm	25	662 020
<b>Stainless steel V2A</b>	19 - 36 mm	$\varnothing$ 23 mm	25	662 021
<b>Stainless steel V2A</b>	36 - 52 mm	$\varnothing$ 23 mm	20	662 022

Terminal clamp, heavy-duty type, to mount the **HVC-85** conductor to steel constructions or railings with fixing bush, **aluminium**, and fastener, **stainless steel V2A**  $\varnothing$  28 mm.

Specification	Clamping area	Fit	PU	Order no.
<b>Stainless steel V2A</b>	5 - 19 mm	$\varnothing$ 28 mm	25	612 020
<b>Stainless steel V2A</b>	19 - 36 mm	$\varnothing$ 28 mm	25	612 021
<b>Stainless steel V2A</b>	36 - 52 mm	$\varnothing$ 28 mm	20	612 022

Beam clip for **HVC-50** conductor; screwed on (for conductor relief) and snapped on (to fix the position)

Specification	Clamping range	Fit	PU	Order no.
Conductor fastener plastic	8 - 12.5 mm	$\varnothing$ 23 mm	50	674 006
Beam clip steel/hot galvanized		snapped on		
Conductor fastener <b>stainless steel V2A</b>	8 - 12.5 mm	$\varnothing$ 23 mm	50	674 007
Beam clip steel/hot galvanized		screwed on		

Additional clamping range on request.

Beam clip for **HVC-85** conductor; screwed on (for conductor relief) and snapped on (to fix the position)

Specification	Clamping range	Fit	PU	Order no.
Conductor fastener plastic	8 - 12.5 mm	$\varnothing$ 28 mm	50	624 006
Beam clip steel/hot galvanized		snapped on		
Conductor fastener <b>stainless steel V2A</b>	8 - 12.5 mm	$\varnothing$ 28 mm	50	624 007
Beam clip steel/hot galvanized		screwed on		

Additional clamping range on request.



**Pipe clamp**, to mount the **HVC-50** conductor on pipes or railings with fixing bush, aluminium, and fastener, **stainless steel V2A**  $\varnothing$  23 mm.

Specification	Fit	Pipe- $\varnothing$	PU	Order no.
Pipe clamp <b>stainless steel V2A</b>	$\varnothing$ 42.4 - 60.3 mm	1 1/4" - 2"	20	662 030 
with mounting screw <b>stainless steel V2A</b>	$\varnothing$ 42.4 - 88.9 mm	1 1/4" - 3"	20	662 031

**Pipe clamp**, to mount the **HVC-85** conductor on pipes or railings with fixing bush, aluminium, and fastener, **stainless steel V2A**  $\varnothing$  28 mm.

Specification	Fit	Pipe- $\varnothing$	PU	Order no.
Pipe clamp <b>stainless steel V2A</b>	$\varnothing$ 42.4 - 60.3 mm	1 1/4" - 2"	20	612 030 
with mounting screw <b>stainless steel V2A</b>	$\varnothing$ 42.4 - 88.9 mm	1 1/4" - 3"	20	612 031

**Tape pipe clamp**, to mount the **HVC-50** conductor on pipes up to 300 mm with fixing bush, aluminium, and fastener, **stainless steel V2A**  $\varnothing$  23 mm. Height of conductor 100 mm.

Specification	Pipe- $\varnothing$	PU	Order no.
Tape pipe clamp with tensioning strap <b>stainless steel V2A</b>	up to $\varnothing$ 300 mm	10	662 041 
Tape pipe clamp without tensioning strap <b>stainless st. V2A</b>	-	20	662 040
Tensioning strap <b>stainless steel V2A</b> , 22 x 0.4 mm	-	25 m	913 825
	-	50 m	913 831

**Tape pipe clamp**, to mount the **HVC-85** conductor on pipes up to 300 mm with fixing bush, aluminium, and fastener, **stainless steel V2A**  $\varnothing$  28 mm. Height of conductor 100 mm.

Specification	Pipe- $\varnothing$	PU	Order no.
Tape pipe clamp with tensioning strap <b>stainless steel V2A</b>	up to $\varnothing$ 300 mm	10	612 041 
Tape pipe clamp without tensioning strap <b>stainless st. V2A</b>	-	20	612 040
Tensioning strap <b>stainless steel V2A</b> , 22 x 0.4 mm	-	25 m	913 825
	-	50 m	913 831

**Tape pipe clamp low type**, to mount the **HVC-50** conductor on pipes up to 300 mm. With tensioning tape and conductor fastener **V2A**  $\varnothing$  23 mm. Height of conductor 30 mm.

Specification	Pipe- $\varnothing$	PU	Order no.
Tape pipe clamp with tensioning strap <b>stainless steel V2A</b>	$\varnothing$ 50 - 150 mm	10	662 045 
Tape pipe clamp with tensioning strap <b>stainless steel V2A</b>	$\varnothing$ 50 - 300 mm	10	662 046
Tape pipe clamp without tensioning strap	-	20	662 047
Tensioning strap <b>stainless steel V2A</b> , 15 x 0.4 mm	-	25 m	110 248

**Tape pipe clamp low type**, to mount the **HVC-85** conductor on pipes up to 300 mm. With tensioning tape and conductor fastener **V2A**  $\varnothing$  28 mm. Height of conductor 30 mm.

Specification	Pipe- $\varnothing$	PU	Order no.
Tape pipe clamp with tensioning strap <b>stainless steel V2A</b>	$\varnothing$ 50 - 150 mm	10	612 045 
Tape pipe clamp with tensioning strap <b>stainless steel V2A</b>	$\varnothing$ 50 - 300 mm	10	612 046
Tape pipe clamp without tensioning strap	-	20	612 047
Tensioning strap <b>stainless steel V2A</b> , 15 x 0.4 mm	-	25 m	110 248

## Pipe clamp



Order no. 612 030

## Tape pipe clamp



Order no. 612 040



Order no. 612 041

## Tape pipe clamp (low type)



Order no. 612 045



## Equipotential bonding clamp



Order no. 612 051

## Equipotential bonding clamp

Equipotential bonding clamp,  
with self-sealing and bonding plate for **HVC-50** conductor

Specification	Fit	PU	Order no.
Stainless steel V2A	Square profile 9 mm	1	662 050
Stainless steel V2A	6 mm <sup>2</sup> (ø 2.8 mm) - 50 mm <sup>2</sup> (ø 8 mm)	1	662 051

Equipotential bonding clamp,  
with self-sealing and bonding plate for **HVC-85** conductor

Specification	Fit	PU	Order no.
Stainless steel V2A	Square profile 9 mm	1	612 050
Stainless steel V2A	6 mm <sup>2</sup> (ø 2.8 mm) - 50 mm <sup>2</sup> (ø 8 mm)	1	612 051

### Mounting with cutting tool (look at page 170):



- 1 Clean HVC-conductor
- 2 Position cutting tool congruently



- 3 Screw the cutting tool down and afterwards open it

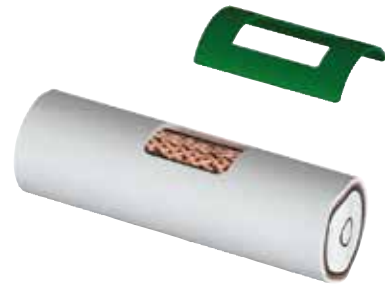

- 4 Remove cut material and cutting tool (expose copper shield braid)
- 5 Pull off foil from sealing and stick on one side

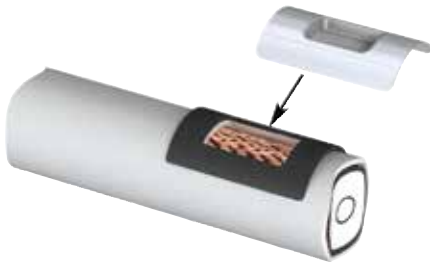

- 6 Pull off foil from sealing and stick on bonding plate



- 7 Position and tighten mounting clamp with bonding plate (10 Nm)



- 8 Attachment of the equipotential bonding conductor



## Accessories for HVC-50 and HVC-85

### Attention sign, "Attention Equipotential bonding" / "Achtung Potentialausgleich"

Specification	Language	Fit	PU	Order no.
Aluminium with adhesive label	German	2 x ø 6.5 mm Hole spacing 125 mm	1	640 000
Aluminium with adhesive label	English	2 x ø 6.5 mm Hole spacing 125 mm	1	640 001
Adhesive label	German	95 mm x 55 mm	1	640 002
Adhesive label	English	95 mm x 55 mm	1	640 003

### Attention sign, "Attention Equipotential bonding" / "Achtung Potentialausgleich"

Specification	Language	Fit	PU	Order no.
Aluminium with adhesive label	German	2 x ø 6.5 mm Hole spacing 125 mm	1	640 004
Aluminium with adhesive label	English	2 x ø 6.5 mm Hole spacing 125 mm	1	640 005
Adhesive label	German	95 mm x 55 mm	1	640 006
Adhesive label	English	95 mm x 55 mm	1	640 007

### Conductor fastener for exterior air termination installation of the HVC-conductor in the area of the insulated support GRP Ø 48 mm. As complete-Set or single fastener.

Specification	Clamping range	Fit	PU	Order no.
<b>NEW!</b> Complete-Set consisting of: 3x conductor fastener plastic with cable tie 1x terminal plate aluminium	Ø 48 mm	up to 4 HVC conductors (HVC-50 / HVC-85)	1	632 448
<b>NEW!</b> Single fastener 1x conductor fastener plastic with cable tie	Ø 48 mm	up to 4 HVC conductors (HVC-50 / HVC-85)	1	632 449

### Positioning support with bracket made of round material for easier installation of the conductor when interior pole installation

Specification	Fit (Pole diameter)	PU	Order no.
<b>NEW!</b> Stainless steel V2A	Ø 42 mm	1	640 040
<b>NEW!</b> Stainless steel V2A	Ø 60 mm	1	640 041

### Terminal plate, for exterior air termination installation of the HVC-conductor. Up to 4 contact connections are possible.

Specification	Fit	PU	Order no.
Aluminium	ø 10.5 mm	1	632 400

### Cable tie, UV-resistant and weatherproof

Specification	Length	PU	Order no.
Plastic black	7.6 x 560 mm	100	640 010

### Cover cap, to prevent water and dirt entering during transport.

Specification	Fit	PU	Order no.
Plastic blue	ø 28 mm (HVC-85 conductor)	10	640 020
Plastic blue	ø 23 mm (HVC-50 conductor)	10	690 020

## Attention sign



Order no. 640 000

Order no. 640 003



Order no. 640 005

Order no. 640 006

## Conductor fastener

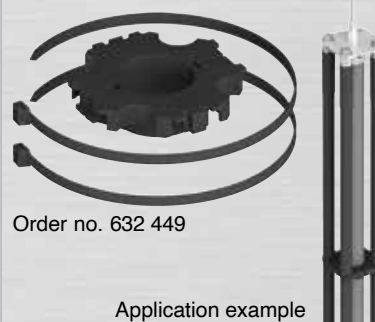

Order no. 632 449

Application example

## Positioning support



Order no. 640 041

## Terminal plate



Order no. 632 400



Terminal plate order no. 632 400 + head-unit e.g. order no. 601 100 (on page 150 and 154)

## Cover cap

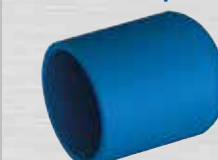

Order no. 640 020



**J.P.**  
*Innovation:*

**HVC-protected**

Insulation test for HVC-50 and HVC-85



The HCV-50 and HVC-85 conductors are the first insulated conductors used in lightning protection that can be tested for function. Here, for the first time, it is possible to determine by a simple and practical measurement that no lightning-induced insulation breakdown of the insulated cables has occurred and that they are therefore still safe and fully functional. A real innovation from the house of J. Pröpster.

**Benefits:**

- Regular insulation testing of the HVC lines
- Simple and practical implementation of the insulation test
- Permanent protection can be guaranteed

Existing test joint (base -unit-SET):



Required test-equipment for the insulation test:



ongoing insulation test:



For further information material respectively further questions our technical advisors will gladly assist you.





## Supplementary articles for the insulation test

**Base-unit-SET**, consisting of equipotential bonding clamp, connection piece, head-unit with connecting bolt and disconnection clamp HVC

Specification	Fit	PU	Order no.
Stainless steel V2A	ø 23 mm (HVC-50)	1	652 210
Stainless steel V2A	ø 28 mm (HVC-85)	1	602 210

**BLACKex milling-head**, to remove the Intermediate black layer.

Specification		PU	Order no.
BLACKex milling-head	To be used <b>with</b> a cordless screwdriver completely with adapter and BLACKex milling-head. For <b>HVC-50</b>	1	650 575
BLACKex Replacement head	completely with cutting plates and plastic housing. For <b>HVC-50</b>	1	650 571
BLACKex milling-head	To be used <b>with</b> a cordless screwdriver completely with adapter and BLACKex milling-head. For <b>HVC-85</b>	1	600 575
BLACKex Replacement head	completely with cutting plates and plastic housing. For <b>HVC-85</b>	1	600 571
Replacement blade	cutting plates inclusive screws and nuts for fixing ( <b>HVC-50</b> and <b>HVC-85</b> )	1	600 573

**Insulation cap**, with inner thread M10 compatible for **HVC-50** and **HVC-85**

Specification	Length	PU	Order no.
PE black, for detached head-units	205 mm	1	600 620
PE black, for measuring points	110 mm	1	600 621

**Insulation measuring device and accessories**

Specification	PU	Order no.
<b>Insulation measuring device Megger MIT1525</b> including measuring clamp in red, black and blue testvoltage: up to 15 kV case: 360 x 305 x 194 mm, IP 65 (closed) weight: ca. 6.5 kg	1	600 610
<b>Discharge stick Megger EST35</b> including connection cable and optionally with clamp voltage: up to 35 kV length: 500 mm weight: ca. 0.95 kg	1	600 611
<b>Function earth connection</b> for connecting measuring device and earth black with ring cable lug and clamp length: 1.5 m cable: copper 10 mm <sup>2</sup>	1	600 612

### Base-unit-SET



Order no. 602 210

### BLACKex milling-head



Order no. 650 575

### Insulation cap



Order no. 600 621

### Insulation measuring device



Order no. 600 610

Order no. 600 611



Order no. 600 612



## Peeling tool



Order no. 600 502

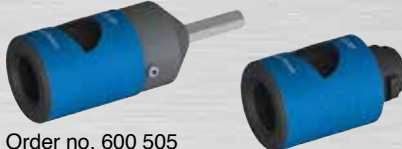

Order no. 600 505

Order no. 600 501

## Stripping knife



Order no. 600 510

## Shear for conductor



Order no. 600 520

## Shear for shield braid



Order no. 600 530

## Torque wrench



Order no. 600 540

## Unwinder for reel



Order no. 600 550

## Cutting tool



Order no. 600 560

## Installation tools for HVC-50 and HVC-85

**Peeling tool**, for uncovering the internal conductor of the HVC-conductor.

Specification		PU	Order no.
Peeling tool	Completely with handle and peeling head. For <b>HVC-50</b>	1	650 502
Peeling tool head	Matching for the handle piece or adapter. For <b>HVC-50</b>	1	650 501
Substitute blades	For the peeling tool head <b>HVC-50</b> and <b>HVC-85</b>	1	600 503
Peeling tool	To be used <b>with</b> a cordless screwdriver, completely with adapter and peeling tool head. For <b>HVC-50</b>	1	650 505
Adapter	For the use of the peeling head with a cordless screwdriver	1	600 504
Peeling tool	Completely with handle and peeling head. For <b>HVC-85</b>	1	600 502
Peeling tool head	Matching for the handle piece or adapter. For <b>HVC-85</b>	1	600 501
Peeling tool	To be used <b>with</b> a cordless screwdriver, completely with adapter and peeling tool head. For <b>HVC-85</b>	1	600 505

**Stripping knife**, to remove the outer jacket of the HVC-conductor.

Specification		PU	Order no.
Stripping knife for <b>HVC-50</b> conductor		1	650 510
Stripping knife for <b>HVC-85</b> conductor		1	600 510

**Shear for conductor**, to cut the HVC-conductor with ratchet mechanism

Specification		PU	Order no.
Shear for conductor for HVC-50 and HVC-85		1	600 520

**Shear for shield braid**,  
to cut the shield braid of the HVC-conductor.

Specification		PU	Order no.
Shear for shield braid		1	600 530

**Torque wrench**, to mount the head-unit or base-unit

Specification	torque	Bits	PU	Order no.
Torque wrench	adjustable 2 - 6 Nm	hex 3 mm	1	600 540

**Unwinder for reel**, to unwind the HVC-conductor.

Specification		PU	Order no.
To unwind 50 m and 100 m reels		1	600 550
Suitable for a reel width up to 520 mm			

**Cutting tool** for uncovering the contact surface to install the equipotential bonding clamp on the HVC-conductor.

Specification for <b>HVC-50</b> conductor		PU	Order no.
Stainless steel V2A with crank handle		1	650 560
Stainless steel V2A for use with cordless screwdriver		1	650 561
Cutting head hardened steel for cutting tool		1	650 562
Specification for <b>HVC-85</b> conductor		PU	Order no.
Stainless steel V2A with crank handle		1	600 560
Stainless steel V2A for use with cordless screwdriver		1	600 561
Cutting head hardened steel for cutting tool		1	600 562



# Accessories

Straightening tools for round wires and strips, screws and earth testers





## Straightening tool



Ord. no. 111 080

## Straightening tool



Ord. no. 111 081

## Universal straightening tool



Ord. no. 111 082

## Straightening tool for strips

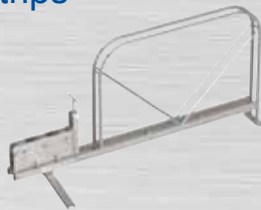

Ord. no. 111 083

## Uncoiling unit



Ord. no. 111 084

## Straightening tool for round wires and strips

### Straightening tool, without reel-off unit.

two-part for wire  $\varnothing$  8-10 mm.

Specification	PU	Ord. no.
Technical data: Weight: 15 kg Consists of 8 Aluminium brackets 60 x 60 x 5 x 350 mm and 6 levelling rolls - steel with bronze bushing sleeve. Wire straightening at 4 levels. Levelling rolls can be adjusted to different degrees of hardness	1	111 080

### Straightening tool, with horizontal reel-off unit.

two-part for wire  $\varnothing$  8-10 mm.

Specification	PU	Ord. no.
Technical data: Weight: 25 kg Straightening device (as described above) Horizontal reel-off unit, adjustable to different coil diameters. Demountable, space saving design.	1	111 081

### Universal straightening tool, with vertical reel-off unit.

To be used for round wire  $\varnothing$  8 - 10 mm and strips 30 x 3.5 mm.

Specification	PU	Ord. no.
Technical data: Weight: 47 kg Straightening device (as described above) Vertical reel-off unit, adjustable to different coil diameters. Uncoiling unit is also suitable for strips 30 x 3.5 mm.	1	111 082

### Straightening tool for strips with 5 levelling rolls, for strips 30 x 3.5 mm.

Specification	PU	Ord. no.
Technical data: Weight: 23 kg Length: 1390 mm, width*: 120 mm, height: 670 mm. (* base can be swivelled in) Uncoil, straighten and install in one step. Very easy handling Time saving installation of strips	1	111 083

### Uncoiling unit for strips 30 x 3.5 mm.

Specification	PU	Ord. no.
Technical data: Weight: 13 kg Length: 1060 mm, width*: 120 mm, height: 670 mm. (* base can be swivelled in) Uncoil, straighten and install in one step. Very easy handling Any extra uncoiled strip can be rolled up again.	1	111 084



## Straightening tool for round wires and strips

### Manual straightening and bending tool - light version

manual tool for round wires.

Specification	Weight	Fit	PU	Ord. no.
Made of forged steel - chromium-plated surface, hardened straightening bolts. Optimal straightening geometry for fast straightening and bending of round wires.	280 g	ø 8-10 mm wrench width 13 and 17	1	110 247

### Niro-Clip conductor fastener opening tool - for unclipping round wire ø 8 mm from Niro-Clip and roof conductor holder. Bending and straightening function for soft materials (e.g. aluminium up to ø 8 mm)

Specification	Weight	Fit	PU	Ord. no.
Niro-Clip opening tool made of polyamide with bi-hexagon wrench width 13/17	54 g	ø 8 mm	1	110 230

### Manual straightening and bending tool - to unclip round wires from Niro-Clip.

Specification	Weight	Fit	PU	Ord. no.
Steel, hot galvanized	500 g	ø 8 mm	1	1049

### Manual straightening tool - for round wires.

Specification	Weight	Fit	PU	Ord. no.
as tube with levelling studs	330 g	ø 8-10 mm	1	110 245

### Manual straightening tool - for strips.

Specification	Weight	Fit	PU	Ord. no.
as tube with levelling studs and bending slots	600 g	ø 8-10/30 mm	1	110 246

### Manual straightening and bending tool - heavy-duty type

manual tool for wire and strip straightening.

Specification	Weight	Fit	PU	Ord. no.
Consisting of a stainless steel V2A tube, PVC handle and a swiveling straightening head made of hardened steel, with 3 attached straightening bolts and an alignment slot. <b>The 9 steps adjustable straightening head can be optimally fitted to the respective work situation.</b>	1200 g	ø 10 mm flat 30	1	110 244



### Manual straightening tool - light version



Ord. no. 110 247

### Niro-Clip opener



Ord. no. 110 230

### Manual straightening and bending tool



Ord. no. 1049

### Manual straightening tool - for round wires



Ord. no. 110 245

### Manual straightening tool - for strips



Ord. no. 110 246

### Manual straightening tool - heavy-duty type



Ord. no. 110 244



## Corrosion prevention tape



Ord. no. 1024

## Heat shrink tubing



Ord. no. 102 209

## Prönit



Ord. no. 111 446

## Screws and accessories



similar to DIN 84

DIN 603

DIN 933

DIN 7504

DIN 7981

DIN 7996

DIN 934

DIN 7337

Shoulder screw

Expansion dowel

Impact dowel with nail screw

## Corrosion prevention tape

for corrosion protection of conductor connections in the soil.

Specification	Width	PU	Ord. no.
Corrosion prevention tape as 10 m long rolls	50 mm	1	1024
	100 mm	1	1025
Corrosion prevention tape according to EN 12068 and DIN 30672 with single-sided laminated PE protective foil as 10 m long rolls	50 mm	1	1068
	100 mm	1	1069

No need to wear safety gloves

## Heat shrink tubing, for corrosion protection of connectors, strips and rods.

Specification	Fit	PU	Ord. no.
Heat shrink tubing (black)	ø 9-16 mm	50 m	102 208
	fl. 30 mm	50 m	102 209

## Prönit -

Special concrete with high swellability to be used as a compound to improve the earth resistance.

Specification	PU	Ord. no.
Powder in sacks	25 kg	111 446

## Screws and accessories

Specification	Dimensions	PU	Ord. no.
<b>Cylinder head screw similar to DIN 84 slotted and cross recessed PH3</b>			
Stainless steel V2A	M6x12 mm	1	84 M 6X12 V2A
	M6x20 mm	1	84 M 6X20 V2A
<b>Carriage bolt DIN 603</b>			
Stainless steel V2A	M10x30 mm	1	603 M10X30 V2A
<b>Hexagon bolt DIN 933</b>			
Stainless steel V2A	M6x25 mm	1	933 M 6X25 V2A
	M8x25 mm	1	933 M 8X25 V2A
	M10x25 mm	1	933 M10X25 V2A
<b>Drilling screw DIN 7504 shape K, hexagon wrench width 10 mm</b>			
Stainless steel V2A	ø 6.3x19 mm	1	7504 6,3X19 V2A
<b>Sheet-metal screw DIN 7981 shape C, cross recessed PH3</b>			
Stainless steel V2A	ø 6.3x19 mm	1	7981 6,3X19 V2A
<b>Halfround-wood screw DIN 7996 cross recessed PH2</b>			
Stainless steel V2A	ø 5x45 mm	1	7996 5X45 V2A
<b>Washer DIN 125 shape A (without chamfer)</b>			
Stainless steel V2A	for screw M6	1	125 A 6,4 V2A
	for screw M8	1	125 A 8,4 V2A
	for screw M10	1	125 A 10,5 V2A
<b>Spring lock washer DIN 127 shape B (smooth)</b>			
Stainless steel V2A	for screw M6	1	127 B 6 V2A
	for screw M8	1	127 B 8 V2A
	for screw M10	1	127 B10 V2A
<b>Hexagon nut DIN 934</b>			
Stainless steel V2A	M6	1	934 M 6 V2A
	M8	1	934 M 8 V2A
	M10	1	934 M10 V2A
<b>Blind rivet DIN 7337</b>			
Stainless steel V2A/Aluminium	ø 5.0x12 mm	1	7337 5,0X12 ALU/V2A
Stainless steel V2A	ø 5.0x12 mm	1	7337 5,0X12 V2A/V2A
<b>Shoulder screw</b>			
Steel electrogalvanized	M6x6 / ø 6x44 mm	1	1244 M6X50 GAL
	M8x6 / ø 6x44 mm	1	1244 M8X50 GAL
<b>Expansion dowel</b>			
Nylon	ø 8x40 mm	1	903 8X40
<b>Impact dowel with nail screw cross recessed PH2</b>			
Nylon / Stainless steel V2A	ø 6x40 mm	1	903 6X40 V2A
<b>Frame dowel with screw Torx T30</b>			
Nylon / Steel electrogalvanized	ø 8x120 mm	1	903 8x120
	ø 8x220 mm	1	903 8x220

Heavy-duty anchor bolts on page 156. Additional dimensions on request



## Mounting aid for connecting clamps (e.g. 111 330 on page 116/117)

Mounting aid for connecting clamps (e.g. 111 330) -  
for simple mounting, also in difficult to access reinforcement cages

Specification		Length	PU	Ord. no.
Magnetic socket wrench width 17; <b>Drive with Hexagon wrench width 10</b>	without lengthening and handle	40 mm	1	110 241
	with lengthening 400mm and freewheeling handle	400 mm	1	110 242
	with lengthenings 800mm and freewheeling handle	800 mm	1	110 243
Magnetic socket wrench width 17; <b>Drive with 1/2 inch square drive</b>	with lengthening 400mm and freewheeling handle	400 mm	1	110 342
	with lengthening 800mm and freewheeling handle	800 mm	1	110 343
<b>Spring-loaded</b> magnetic socket wrench width 17; <b>Drive with Hexagon wrench width 10</b>	without lengthening and handle	116 mm	1	110 441
	with lengthening 400mm and freewheeling handle	400 mm	1	110 442
	with lengthening 800mm and freewheeling handle	800 mm	1	110 443

Note:  
connecting clamps on page 99.

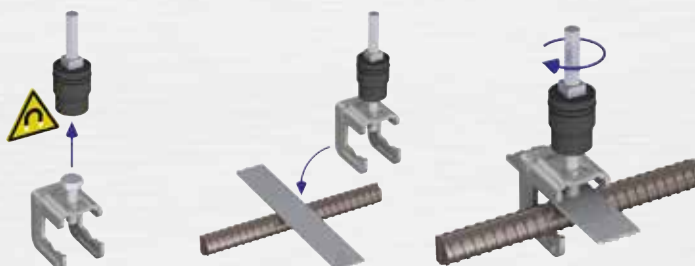

Place magnetic side of the socket wrench on the hexagon bolt of the connecting clamp.

Positioning of the clamp.

Tighten the positioned clamp until the required torque is reached (cordless screw-driver could be used).

## Lightning strike counter, P-LSC 1,

Type	Ord. no.
P-LSC 1	306 015

Technical data	
Threshold current (8/20 $\mu$ s) $I_{tc}$	1 kA
<b>Maximum counting discharge current (10/350 <math>\mu</math>s) <math>I_{mcw}</math></b>	100 kA
Protection class	IP 65
Mounting on	flat- and round conductors
Fit	$\varnothing$ 8-10 mm / fl. 30 mm
Count area	999
Average battery lifetime	5 years
Operating temperature range	-20 °C ... +60 °C
Dimensions LxBxH (mm)	144 x 88 x 44 mm
Test standard	EN 62561-6

## Spark gaps

### Protective spark gap

made of porcelain with corrosion proof connectors e.g. for roof racks

Specification	Power frequency withstand voltage ( $U_{aw}$ )	PU	Ord. no.
with connection bolt made of stainless steel V2A $\varnothing$ 10 mm	~ 2.5 kV (50 Hz)	1	111 061

Isolating spark gap encapsulated with plastic coating; anti-tracking.

Specification	PU	Ord. no.
with connection bolt made of stainless steel V2A $\varnothing$ 8mm	1	111 065

Technical data:	
Power frequency withstand voltage	$U_{aw}$ < 2.5 kV (50 Hz)
Lightning impulse current	$I_{imp}$ 100 kA (10/350 $\mu$ s)

## Mounting aid



Application example:  
Ord. no. 110 441

## Lightning strike counter



Ord. no. 306 015

## Protective spark gaps



Ord. no. 111 061

## Isolating spark gaps



Ord. no. 111 065



## Earth and soil resistivity tester



Ord. no. 2062



Ord. no. 2098

### Accessory set for earth and soil resistivity tester



Ord. no. 2063

## Clamp-on ground resistance tester



Ord. no. 2084



Ord. no. 2086

## Continuity tester/insulation tester



Ord. no. 2061

## Earth tester

Tester for measuring earth and soil resistivity with digital-display (LCD).

Specification	PU	Ord. no.
<b>C.A 6460 - earth and soil resistivity tester</b>	1	2062
Range: 0.00 ... /2000 Ω within three ranges automatic range change		
Measurement frequency: 128 Hz		
Case: 273 x 247 x 127 mm, IP 53		
Weight: ~ 2.8 kg		
<b>C.A 6462 - earth and soil resistivity tester</b>	1	2062 S
Equal to C.A 6460 with an internal charger		
Weight: ~ 3.3 kg		
<b>C.A 6422 - earth tester with an internal charger</b>	1	2098
Range: 0.5 - 50,0 kΩ automatic range change		
Measurement frequency: at 128 Hz interference voltage		
Case: 223 x 126 x 70 mm, IP 65		
Weight: 1.0 kg		

## Earth tester case

Specification	PU	Ord. no.
Earth tester case including 2 earth spikes (T-shaped)	1	2063
Cable: flat spool: green 10 m; wire coils: blue 1 x 150 m red 1 x 150 m,		
1 set of connection clamps and hammer in carrying bag		

## Clamp-on ground resistance tester

measuring instrument to review ground loops, with digital-display (OLCD).

Specification	PU	Ord. no.
<b>C.A 6416 - clamp-on ground resistance tester</b>	1	2081
Range: Loop impedance measurement: 0.01 - 1500 Ω Loop inductivity measurement: 10 - 500 μH Current measurement: 0.2 mA - 40 A		
Measurement frequency: 2083 Hz		
Data storage: 300 measurements with time stamp.		
Case: 262 x 95 x 55 mm		
Weight: ~ 1.0 kg		
<b>C.A 6417 - clamp-on ground resistance tester</b>	1	2084
Equal to C.A 6416 but with Bluetooth, Software GTC and data storage for 2000 measurements with time stamp		
<b>C.A 6418 - clamp-on ground resistance tester</b>	1	2086
Range: Loop impedance measurement: 0.01 - 1200 Ω Current measurement: 0.5 mA - 20 A		
Measurement frequency: 2083 Hz		
Data storage: 300 measurements with time stamp.		
Case: 300 x 103 x 56 mm		
Weight: ~ 1.2 kg including battery		
Calibration loop for clamp-on ground resistance tester	1	2090

## Continuity and insulation tester

e. g. for standardized continuity testing with a test current of 200 mA.

Specification	PU	Ord. no.
<b>C.A 6528 - Continuity and insulation tester</b>	1	2063 S
Test current for continuity testing: 200 mA according to EN 61557-4		
Continuity testing with buzzer.		
Insulation testing: 250 V / 500 V / 1000 V		
Voltage measurement: 1 to 700 V AC/DC		
Case: 218 x 95 x 63 mm		
Weight: ca. 760 g		





# Surge protection

Power supply, photovoltaic systems, measurement and control technology, information technology





## High energy combined lightning current and surge arrester *max*, type 1+2

multipole / mains system compliant e.g. for industrial plants

- Benefits:**
- Safe fixation and contact ensured by module locking mechanism.
  - P-HMS 280 *max* having 25 kA (10/350  $\mu$ s) /pole and 100 kA (10/350  $\mu$ s) 4-pole.
  - Max. backup fuse 250 A gL/gG.

### P-HMS 280 *max*



Ord. no. 317 235



Ord. no. 317 247

### P-HMS 280 (Fm) *max*, (class I+II)//LPZ 0<sub>A</sub>-LPZ 2

#### Combined lightning current and surge arrester, pluggable

Type		System	Ord. no.
P-HMS 280 <i>max</i> 3	3-pole	TN-C	317 235
P-HMS 280 <i>max</i> 4	4-pole	TN-S	317 255
P-HMS 280 <i>max</i> 3+1	3+1-pole	TT	317 245

#### Combined lightning current and surge arrester, pluggable

Type with remote signalling contact (Fm)		System	Ord. no.
P-HMS 280 Fm <i>max</i> 3	3-pole	TN-C	317 237
P-HMS 280 Fm <i>max</i> 4	4-pole	TN-S	317 257
P-HMS 280 Fm <i>max</i> 3+1	3+1-pole	TT	317 247

#### Technical data

Type P-HMS 280 (Fm) <i>max</i>	3-pole	4-pole	3+1-pole
Mains system	TN-C	TN-S	TT
Dimensions	6 mods.	8 mods.	8 mods.
Nominal discharge current (8/20 $\mu$ s) /total I <sub>n</sub>	120 kA	120 kA	100 kA
Max. discharge current (8/20 $\mu$ s) /total I <sub>max</sub>	150 kA	150 kA	150 kA
<b>Lightning impulse current (10/350) /total I<sub>imp</sub></b>	<b>75 kA</b>	<b>100 kA</b>	<b>100 kA</b>
Voltage protection level U <sub>p</sub>	< 1.3 kV	< 1.3 kV	< 1.5 kV
Response time t <sub>A</sub>	< 25 ns	< 25 ns	< 100 ns
<b>Max. backup fuse</b>	<b>250 A gL/gG</b>		
<b>parallel wiring</b>	<b>125 A gL/gG</b>		
<b>serial wiring</b>	<b>125 A gL/gG</b>		
Max. continuous operating voltage U <sub>c</sub>	L-N 280 V~ / N-PE 255 V~		
Cross section for connection	min. 4 mm <sup>2</sup> single-core/ finely-stranded max. 50 mm <sup>2</sup> stranded / 35 mm <sup>2</sup> finely-stranded		

## Important notes and explanations for the section "surge protection"!

For surge protective devices, that are marked with "Fm", the following applies:

Remote signalling contact (Fm):

Contact	Change-over contact
Switching capacity	250 V / 5.0 A~ 75 V / 0.75 A- 125 V / 0.5 A- 250 V / 0.25 A-
Cross-section for connection	0.08 - 1.5 mm <sup>2</sup>

Diagram:

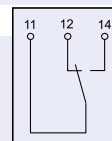

For all surge protective devices illustrated in the catalogue the following applies:

Dimensions according to DIN 43 880	17.5 mm (1 mod. = 18 mm)	
Temperature range	- 40 °C ... + 80 °C, unless otherwise specified	
Housing material	Thermoplast UL 94 V-0	
IP Code	IP 20	
Mounting on DIN rail	35 mm according to EN 60715	
Installation tool	Screwdriver:	Slot, size 5.5
		Phillips, size 3
Function indicator of type 1+2 and type 2 rail-mounted device	OK:	GREEN or TRANSPARENT
	Defect::	Logo "DEFECT"

**Important:** Defect arresters offer no protection and must be replaced!

If specifications differ, please refer to the information supplied in the "technical data" tables for the respective device.



## Space-saving combined lightning current and surge arrester, type 1+2 P-ZP NEW!

leakage-current free; multipole / mains system compliant

- Benefits:**
- Quick and easy installation by snapping onto 40 mm busbar systems.
  - Fully compliant with the German VDE-AR-N 4100 directive to use the SPD upstream of the electric meter.
  - VDE tested quality and safety.
  - Leakage-current free due to series connection of gas discharge tube and varistor.
  - No follow current.
  - P-ZP Ph with additional load contact.
  - P-ZP Ph 3+1 having 12.5 kA (10/350  $\mu$ s)/pole and 50 kA (10/350  $\mu$ s) as 3+1-pole.
  - Optimal price/performance ratio.
  - Max. backup fuse 315 A gG.
  - Space-saving design with a width of 47 mm.

P-ZP; (class I+II)/BSZ 0<sub>A</sub>-BSZ 2

Combined lightning current and surge arrester with 7.5 kA (10/350 $\mu$ s) / pole		
Type	System	Ord. no.
P-ZP B 3	TN-C	<b>336 130</b>
P-ZP B 3+1	TN-S / TT	<b>336 140</b>
Combined lightning current and surge arrester mit 12.5 kA (10/350 $\mu$ s) / pole		
Type	System	Ord. no.
P-ZP Ph 3	TN-C	<b>337 133</b>
P-ZP Ph 3+1	TN-S / TT	<b>337 143</b>

Technical data: Type P-ZP

Ord. no.	336 130	337 133	336 140	337 143
Mains system	TN-C	TN-C	TN-S / TT	TN-S / TT
Lightning impulse current (10/350 $\mu$ s) / pole $I_{imp}$	7.5 kA	12.5 kA	7.5 kA / 30 kA [N-PE]	12.5 kA / 50 kA [N-PE]
<b>Lightning impulse current (10/350)/total <math>I_{imp}</math></b>	<b>22.5 kA</b>	<b>37.5 kA</b>	<b>30 kA</b>	<b>50 kA</b>
Nominal discharge current (8/20 $\mu$ s) /total $I_n$	60 kA		80 kA	
Max. discharge current (8/20 $\mu$ s) / pole $I_{max}$	50 kA		50 kA / 100 kA [N-PE]	
Voltage protection level $U_p$	< 1.5 kV			
Response time $t_A$	< 100 ns			
<b>Max. backup fuse</b>	<b>315 A gG</b>			
Max. continuous operating voltage $U_c$	300 V~			
Cross section for connection	max. 35 mm <sup>2</sup> single-core/multi-stranded / 25 mm <sup>2</sup> finely-stranded			
Test standard	EN 61643-11			
Approval	VDE			

Example of application:

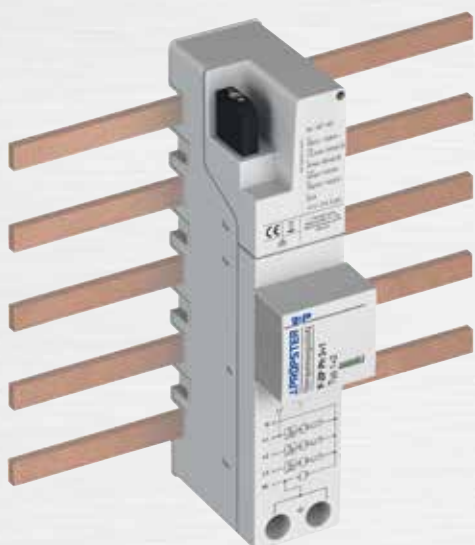

P-ZP NEW!



Ord. no. 336 140



Ord. no. 337 143



## Combined lightning current and surge arrester, type 1+2

leakage-current free; multipole / mains system compliant

- Benefits:**
- Leakage-current free due to series connection of gas discharge tube and varistor.
  - Safe fixation and contact ensured by module locking mechanism.
  - P-HMS 280 G having 12.5 kA (10/350  $\mu$ s) /pole and 50 kA (10/350  $\mu$ s) 4-pole.
  - Max. backup fuse 160 A gL/gG.
  - Optimal price/performance ratio.
  - Min. cross section for connection 4 mm<sup>2</sup>

### P-HMS 280 G



Ord. no. 327 230



Ord. no. 327 242

### P-HMS 280 (Fm) G; (class I+II)//LPZ 0<sub>A</sub>-LPZ 2

#### Combined lightning current and surge arrester, pluggable

Type		System	Ord. no.
P-HMS 280 G 2	2-pole	TN	327 220
P-HMS 280 G 1+1	1+1-pole	TT	327 210
P-HMS 280 G 3	3-pole	TN-C	327 230
P-HMS 280 G 4	4-pole	TN-S	327 250
P-HMS 280 G 3+1	3+1-pole	TT	327 240

#### Combined lightning current and surge arrester, pluggable

Type with remote signalling contact (Fm)		System	Ord. no.
P-HMS 280 Fm G 2	2-pole	TN	327 222
P-HMS 280 Fm G 1+1	1+1-pole	TT	327 212
P-HMS 280 Fm G 3	3-pole	TN-C	327 232
P-HMS 280 Fm G 4	4-pole	TN-S	327 252
P-HMS 280 Fm G 3+1	3+1-pole	TT	327 242

#### Technical data

Type P-HMS 280 (Fm) G	2-pole	1+1-pole	3-pole	4-pole	3+1-pole
Mains system	TN	TT	TN-C	TN-S	TT
Dimensions	2 mods.	2 mods.	3 mods.	4 mods.	4 mods.
Nominal discharge current (8/20 $\mu$ s) /total I <sub>n</sub>	50 kA	40 kA	75 kA	100 kA	75 kA
Max. discharge current (8/20 $\mu$ s) /total I <sub>max</sub>	80 kA	60 kA	120 kA	150 kA	100 kA
<b>Lightning impulse current (10/350 <math>\mu</math>s) /total I<sub>imp</sub></b>	<b>25 kA</b>	<b>25 kA</b>	<b>37.5 kA</b>	<b>50 kA</b>	<b>50 kA</b>
Voltage protection level U <sub>p</sub>	< 1.5 kV				
Response time t <sub>A</sub>	< 100 ns				
<b>Max. backup fuse</b>	<b>160 A gL/gG</b>				
Max. continuous operating voltage U <sub>c</sub>	255 V~				
Cross section for connection	min. 4 mm <sup>2</sup> single-core/ finely-stranded max. 50 mm <sup>2</sup> stranded / 35 mm <sup>2</sup> finely-stranded				



## Combined lightning current and surge arrester, type 1+2 e.g. for residential or office buildings

- Benefits:**
- Safe fixation and contact ensured by module locking mechanism.
  - P-HMS 280 R having 12.5 kA (10/350  $\mu$ s) /pole and 50 kA (10/350  $\mu$ s) 4-pole.
  - Max. backup fuse 160 A gL/gG.
  - Optimal price/performance ratio.
  - Min. cross section for connection 4 mm<sup>2</sup>

### Multipole/mains system compliant - P-HMS 280 (Fm) R; (class I+II)/LPZ 0<sub>A</sub>-LPZ 2

Combined lightning current and surge arrester, pluggable			
Type		System	Ord. no.
P-HMS 280 R 2	2-pole	TN	317 220
P-HMS 280 R 1+1	1+1-pole	TT	317 210
P-HMS 280 R 3	3-pole	TN-C	317 230
P-HMS 280 R 4	4-pole	TN-S	317 250
P-HMS 280 R 3+1	3+1-pole	TT	317 240

Combined lightning current and surge arrester, pluggable			
Type with remote signalling contact (Fm)		System	Ord. no.
P-HMS 280 Fm R 2	2-pole	TN	317 222
P-HMS 280 Fm R 1+1	1+1-pole	TT	317 212
P-HMS 280 Fm R 3	3-pole	TN-C	317 232
P-HMS 280 Fm R 4	4-pole	TN-S	317 252
P-HMS 280 Fm R 3+1	3+1-pole	TT	317 242

Technical data						
Type P-HMS 280 (Fm) R	2-pole	1+1-pole	3-pole	4-pole	3+1-pole	
Mains system	TN	TT	TN-C	TN-S	TT	
Dimensions	2 mods.	2 mods.	3 mods.	4 mods.	4 mods.	
Nominal discharge current (8/20 $\mu$ s) /total I <sub>n</sub>	60 kA	40 kA	90 kA	120 kA	75 kA	
Max. discharge current (8/20 $\mu$ s) /total I <sub>max</sub>	100 kA	60 kA	150 kA	150 kA	100 kA	
<b>Lightning impulse current (10/350)/total I<sub>imp</sub></b>	<b>25 kA</b>	<b>25 kA</b>	<b>37.5 kA</b>	<b>50 kA</b>	<b>50 kA</b>	
Voltage protection level U <sub>p</sub>	< 1.3 kV	< 1.5 kV	< 1.3 kV	< 1.3 kV	< 1.5 kV	
Response time t <sub>A</sub>	< 25 ns	< 100 ns	< 25 ns	< 25 ns	< 100 ns	
<b>Max. backup fuse</b>	<b>160 A gL/gG</b>					
Max. continuous operating voltage U <sub>c</sub>	L-N 280 V~ / N-PE 255 V~					
Cross section for connection	min. 4 mm <sup>2</sup> single-core/ finely-stranded max. 50 mm <sup>2</sup> stranded / 35 mm <sup>2</sup> finely-stranded					

### Single pole - P-HMS 280 (Fm) R and P-N/PE BC R; (class I+II)/LPZ 0<sub>A</sub>-LPZ 2

Combined lightning current and surge arrester, pluggable		
Type with or without remote signalling contact (Fm)		Ord. no.
P-HMS 280 R	1-pole	317 200
P-HMS 280 Fm R	1-pole, with remote signalling contact	317 202

N/PE combined lightning current and surge arrester for TT-system			
Type		System	Ord. no.
P-N/PE BC R	1-pole	TT	317 260
P-N/PE BC R 50	1-pole	TT	317 262

Technical data			
Type	P-HMS 280 (Fm) R	P-N/PE BC R	P-N/PE BC R 50
Mains system		TT	TT
Dimensions	1 mod.	1 mod.	1 mod.
Nominal discharge current (8/20 $\mu$ s) I <sub>n</sub>	30 kA	40 kA	75 kA
Max. discharge current (8/20 $\mu$ s) I <sub>max</sub>	50 kA	60 kA	100 kA
<b>Lightning impulse current (10/350) I<sub>imp</sub></b>	<b>12.5 kA</b>	<b>25 kA</b>	<b>50 kA</b>
Voltage protection level U <sub>p</sub>	< 1.3 kV	< 1.5 kV	< 1.5 kV
<b>Max. backup fuse</b>	<b>160 A gL/gG</b>	---	---
Max. continuous operating voltage U <sub>c</sub>	280 V~	255 V~	255 V~
Cross section for connection	min. 4 mm <sup>2</sup> single-core/ finely-stranded max. 50 mm <sup>2</sup> stranded / 35 mm <sup>2</sup> finely-stranded		

### P-HMS 280 R



Ord. no. 317 230



Ord. no. 317 242



Ord. no. 317 200

### P-N/PE BC R



Ord. no. 317 260



## Surge arrester, type 2

- Benefits:**
- Safe fixation and contact ensured by module locking mechanism.
  - Min. cross section for connection 4 mm<sup>2</sup>

### P-VMS 280 R



Ord. no. 316 220



Ord. no. 316 224



Ord. no. 316 280

### P-N/PE C (S)



Ord. no. 316 286

### P-VMS 280 (Fm) R; (class II)//LPZ 1-LPZ 2

#### Multipole surge arrester, pluggable

Type		System	Ord. no.
P-VMS 280 R 2	2-pole	TN	316 226
P-VMS 280 R 1+1	1+1-pole	TT	316 228
P-VMS 280 R 3	3-pole	TN-C	316 220
P-VMS 280 R 4	4-pole	TN-S	316 221
P-VMS 280 R 3+1	3+1-pole	TT	316 222

#### Multipole surge arrester, pluggable with remote signalling contact (Fm)

Type		System	Ord. no.
P-VMS 280 Fm R 2	2-pole	TN	316 227
P-VMS 280 Fm R 1+1	1+1-pole	TT	316 229
P-VMS 280 Fm R 3	3-pole	TN-C	316 223
P-VMS 280 Fm R 4	4-pole	TN-S	316 224
P-VMS 280 Fm R 3+1	3+1-pole	TT	316 225

#### Technical data

Type P-VMS 280 (Fm)	2-pole	1+1-pole	3-pole	4-pole	3+1-pole
Mains system	TN	TT	TN-C	TN-S	TT
Dimensions	2 mods.	2 mods.	3 mods.	4 mods.	4 mods.
Nominal discharge current (8/20 μs) /total I <sub>n</sub>	40 kA	40 kA	60 kA	80 kA	40 kA
Max. discharge current (8/20 μs) /total I <sub>max</sub>	80 kA	60 kA	120 kA	150 kA	60 kA
Response time t <sub>A</sub>	< 25 ns	< 100 ns	< 25 ns	< 25 ns	< 100 ns
Voltage protection level U <sub>p</sub>	< 1.3 kV	< 1.5 kV	< 1.3 kV	< 1.3 kV	< 1.5 kV
Max. continuous operating voltage U <sub>c</sub>	L-N 280 V~ / N-PE 255 V~				
<b>Max. backup fuse</b>	<b>125 A gL/gG</b>				
Cross section for connection	min. 4 mm <sup>2</sup> single-core/ finely-stranded max. 50 mm <sup>2</sup> stranded / 35 mm <sup>2</sup> finely-stranded				

### P-VMS (Fm) R und P-N/PE C R; (class II)//LPZ 1-LPZ 2

#### Surge arrester pluggable with or without remote signalling contact (Fm)

Type		Ord. no.
P-VMS 280 R	1-pole	316 280
P-VMS 280 Fm R	1-pole	316 282
with remote signalling contact (Fm)		
P-VMS 440 R	1-pole	316 441
P-VMS 440 Fm R	1-pole	316 443
with remote signalling contact (Fm)		

#### N/PE surge arrester pluggable for TT-System

Type		System	Ord. no.
P-N/PE C R	1-pole	TT	316 286

#### Technical data

Type	P-VMS 280 (Fm) R	P-VMS 440 (Fm) R	P-N/PE C (S) (R)
Dimensions	1 mod	1 mod	1 mod
Max. continuous operating voltage U <sub>c</sub>	280 V~	440 V~	255 V~
Voltage protection level U <sub>p</sub>	< 1.3 kV	< 1.8 kV	< 1.5 kV
Nominal discharge current (8/20 μs) I <sub>n</sub>		20 kA	40 kA
Max. discharge current (8/20 μs) I <sub>max</sub>		40 kA	60 kA
Response time t <sub>A</sub>		< 25 ns	< 100 ns
<b>Max. backup fuse</b>	<b>125 A gL/gG</b>		
Cross section for connection	min. 4 mm <sup>2</sup> single-core/ finely-stranded max. 50 mm <sup>2</sup> stranded / 35 mm <sup>2</sup> finely-stranded		

## Surge arrester type 2+3 P-VM 280 *slim* **NEW!**

multipole / mains system compliant

- Benefits:**
- Narrow dimensions of only 2 mods.
  - Compact design facilitates retrofitting in existing electrical plants.
  - Push-In terminal block for fast connection without tools.
  - Combined medium and fine protection type 2+3.
  - Ideal surge protection for industrial terminal devices with three-phase connection.
  - Min. cross section for connection 0.5 mm<sup>2</sup>.
  - Standard-compliant, economic surge protection solution e.g. for residential and office buildings.
  - Optimal price/performance ratio.

P-VM 280; (class II+III)//BSZ 1-BSZ 3

### Surge arrester

Type	System	Ord. no.
P-VM 280 1+1	TN / TT	<b>346 228</b>
P-VM 280 3	TN-C	<b>346 220</b>
P-VM 280 3+1	TN-S / TT	<b>346 222</b>

### Surge arrester with remote signalling contact (Fm)

Type	System	Ord. no.
P-VM 280 Fm 1+1	TN / TT	<b>346 229</b>
P-VM 280 Fm 3	TN-C	<b>346 223</b>
P-VM 280 Fm 3+1	TN-S / TT	<b>346 225</b>

### Technical data: Type P-VM 280

Ord. no. without Fm	346 228	346 220	346 222
Ord. no. with Fm	<b>346 229</b>	<b>346 223</b>	<b>346 225</b>
Mains system	TN / TT	TN-C	TN-S / TT
Dimensions according to DIN 43880	2 mods.		
Nominal voltage U <sub>N</sub>	230 V~		
Max. continuous operation voltage U <sub>c</sub>	[L-N] / [N-PE]	280 V~ / 255 V~	
Nom. discharge current (8/20 μs) I <sub>n</sub>	[L-N] / [N-PE]	10 kA / -	10 kA / 40 kA
Max. discharge current (8/20 μs) I <sub>max</sub>	[L-N] / [N-PE]	20 kA / -	20 kA / 40 kA
Total discharge current (8/20 μs) I <sub>total</sub>	[L-N]-PE	20 kA	30 kA / 40 kA
Voltage protection level U <sub>p</sub> at I <sub>n</sub>	L-N (PEN)	< 1.3 kV	
Voltage protection level U <sub>p</sub> at I <sub>n</sub>	N-PE	< 1.4 kV	
Max. backup fuse	63 A gL/gG oder C 63 A		
Response time t <sub>A</sub>	< 100 ns	< 25 ns	< 100 ns
Cross section for connection	0.5 - 10 mm <sup>2</sup> single-core/finely-stranded 0.5 - 6 mm <sup>2</sup> with ferrule		
Test standard	EN 61643-11		

P-VM 280 *slim* **NEW!**



Ord. no. 346 222

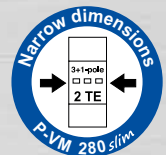



## Surge arrester, type 2+3

Specially designed for the protection of LED applications

### P-LED 230



Ord. no. 306 330



Ord. no. 306 333

P-LED 230 1, P-LED 230 1 IP and P-LED 230 2;  
(class II+III)/LPZ 1-LPZ 3

Surge arrester Type	Protection class	Ord. no.
P-LED 230 1	I	306 330
P-LED 230 1 IP	I	306 332
<b>NEW</b> P-LED 230 1 IP ST	I	306 333
P-LED 230 2	II	306 331

Technical data: P-LED	230 1	230 1 IP	230 2	230 1 IP ST
Protection class (acc. to EN 61140)	I	I	II	I
IP Code	IP 20	IP 65	IP 20	IP 65
Nominal discharge current (8/20 μs) $I_n$		10 kA		5 kA
Max. discharge current (8/20 μs) $I_{max}$		20 kA		10 kA
Nominal voltage $U_N$	230 V~			
Max. continuous operating voltage $U_c$	255 V~			
Voltage protection level $U_p$	< 1.3 kV			
Combination wave $U_{OC}$	6 kV			
<b>Max. back-up fuse</b>	<b>16 A gL/gG or B 16 A</b>			
Dimensions LxWxH (mm)		55x33x12.5		55x33x14

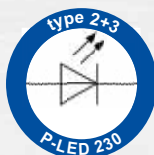

#### P-LED 230 1

Parallel wiring

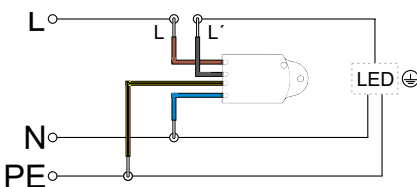

#### P-LED 230 2

Parallel wiring

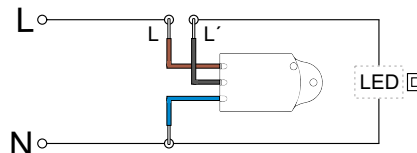

#### P-LED 230 1

Serial wiring

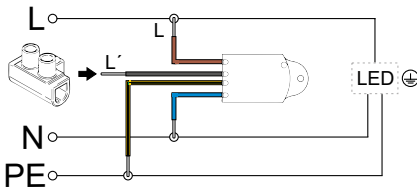

#### P-LED 230 2

Serial wiring

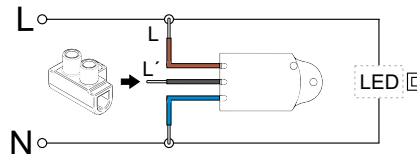





## Surge arrester type 3 fine protection

P-DA, (class III)/LPZ 2-LPZ 3

Type	I <sub>n</sub> (8/20 μs)			Ord. no.
	L/N ⇒ PE	L ⇒ N	L+N ⇒ PE	
P-DA 230	3 kA	3 kA	5 kA	<b>306 460</b>
P-DA 48	1 kA	1 kA	2 kA	<b>306 430</b>
P-DA 24	1 kA	1 kA	2 kA	<b>306 420</b>

### Technical data

Type P-DA		230	48	24
Dimensions		1 mod.		
Nominal voltage U <sub>N</sub>		230 V~	48 V~	24 V~
Max. continuous operating voltage U <sub>c</sub>		255 V~	60 V~	30 V~
Combination wave U <sub>oc</sub>	L+N ⇒ PE	10 kV	4 kV	4 kV
Voltage protection level U <sub>p</sub>	L ⇒ N	< 1300 V	< 400 V	< 225 V
Response time t <sub>A</sub>	L ⇒ N	< 25 ns		
<b>Max. backup fuse</b>		<b>16 A gL/gG or B 16</b>		
Cross section for connection		0.14 - 2.5 mm <sup>2</sup>		
<b>Remote signalling contact (Fm):</b>				
Contact		Floating break contact (21/22)		
Switching capacity		250 V~ / 1 A		
Cross section for connection		0.08 - 1.5 mm <sup>2</sup>		

## P-DA 230



Ord. no. 306 460

## Surge protection for flush-mounted sockets, type 3

P-DA 230 UP, (class III)/LPZ 2-LPZ 3; with acoustic fault indication

Type	Description	Ord. no.
P-DA 230 UP	Surge protective adapter	<b>206 312</b>

### Technical data

Type		P-DA 230 UP
Max. continuous operating voltage U <sub>c</sub>		255 V~
Nominal discharge current (8/20 μs) I <sub>total</sub>	L+N ⇒ PE	6 kA
Voltage protection level U <sub>p</sub>	L/N ⇒ PE	1.3 kV
Response time t <sub>A</sub>	L ⇒ N	< 25 ns
<b>Max. backup fuse</b>		<b>16 A gL/gG or B 16</b>
Dimensions LxWxH (mm)		45x35x12

## P-DA 230 UP

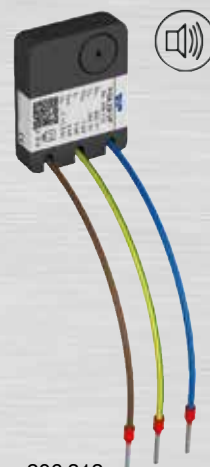

Ord. no. 206 312



## Combined lightning current and surge arrester for photovoltaic systems, type 1+2

- Benefits:**
- Safe fixation and contact ensured by module locking mechanism.
  - Type 1+2 having 12.5 kA (10/350  $\mu$ s) /pole.
  - Min. cross section for connection 4 mm<sup>2</sup>

### P-HYS R PV



Ord. no. 317 766



Ord. no. 317 796

Basic circuit diagram:

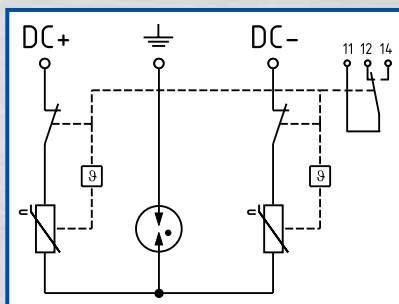

### P-HYS (Fm) R PV, (class I+II)/LPZ 0<sub>A</sub>-LPZ 2

#### Combined lightning current and surge arrester, pluggable

Type	Y-circuit	Ord. no.
P-HYS 605 R PV		317 762
P-HYS 805 R PV		317 782
P-HYS 1005 R PV		317 792

#### Combined lightning current and surge arrester, pluggable

Type with remote signalling contact (Fm)	Y-circuit	Ord. no.
P-HYS 605 Fm R PV		317 766
P-HYS 805 Fm R PV		317 786
P-HYS 1005 Fm R PV		317 796

#### Technical data

Type P-HYS (Fm) R PV	605	805	1005	
Dimensions	3 mods.	3 mods.	5 mods.	
<b>Max. continuous operating voltage <math>U_{CPV}</math></b>	<b>600 V-</b>	<b>800 V-</b>	<b>1000 V-</b>	
Nominal discharge current (8/20 $\mu$ s) $I_n$	DC+ $\rightarrow$ DC-	30 kA		
	DC+/DC- $\rightarrow$ PE	30 kA		
	Gesamt $\rightarrow$ PE	30 kA		
Max. discharge current (8/20 $\mu$ s) $I_{max}$	DC+ $\rightarrow$ DC-	50 kA		
	DC+/DC- $\rightarrow$ PE	50 kA		
	Gesamt $\rightarrow$ PE	60 kA		
Lightning impulse current (10/350 $\mu$ s) $I_{imp}$	DC+ $\rightarrow$ DC-	12.5 kA		
	DC+/DC- $\rightarrow$ PE	12.5 kA		
	total $\rightarrow$ PE	20 kA	18 kA	16 kA
Voltage protection level $U_p$	DC+ $\rightarrow$ DC-	< 2.4 kV	< 2.9 kV	< 3.4 kV
	DC+/DC- $\rightarrow$ PE	< 1.8 kV	< 2.0 kV	< 2.3 kV
	Response time $t_A$	< 100 ns		
Cross section for connection	min. 4 mm <sup>2</sup> single-core/ finely-stranded max. 50 mm <sup>2</sup> stranded / 35 mm <sup>2</sup> finely-stranded			

**Note:** This product series is specially designed for the use in the DC side of **not earthed PV-systems** (not earthed plus or minus pole).  
The maximum continuous operating voltage  $U_{CPV}$  of the device shall be selected to be always higher than the maximum open circuit voltage of the PV-generator!

## Combined lightning current and surge arrester for photovoltaic systems, type 1+2

- Benefits:**
- Safe fixation and contact ensured by module locking mechanism.
  - Type 1+2 having 12.5 kA (10/350  $\mu$ s) /pole.
  - Optimal price-performance ratio.
  - Suitable for PV-systems with earthed plus or minus pole.
  - Min. cross section for connection 4 mm<sup>2</sup>

### P-HYS (Fm) R PV, (class I+II)//LPZ 0<sub>A</sub>-LPZ 2

#### Combined lightning current and surge arrester, pluggable

Type		Ord. no.
P-HYS 600 R PV	Y-circuit	317 761
P-HYS 800 R PV	Y-circuit	317 781
P-HYS 1000 R PV	Y-circuit	317 701

#### Combined lightning current and surge arrester, pluggable

Type with remote signalling contact (Fm)		Ord. no.
P-HYS 600 Fm R PV	Y-circuit	317 765
P-HYS 800 Fm R PV	Y-circuit	317 785
P-HYS 1000 Fm R PV	Y-circuit	317 705

#### Technical data

Type P-HYS (Fm) R PV	600	800	1000
Dimensions	3 mods.	3 mods.	6 mods.
<b>Max. continuous operating voltage U<sub>CPV</sub></b>	<b>600 V-</b>	<b>800 V-</b>	<b>1000 V-</b>
Nominal discharge current (8/20 $\mu$ s) I <sub>n</sub>	(DC+ $\Rightarrow$ DC-)	30 kA	30 kA
	(DC+/DC- $\Rightarrow$ PE)	30 kA	30 kA
Max. discharge current (8/20 $\mu$ s) I <sub>max</sub>	(DC+ $\Rightarrow$ DC-)	50 kA	50 kA
	(DC+/DC- $\Rightarrow$ PE)	50 kA	50 kA
<b>Lightning impulse current (10/350 <math>\mu</math>s) I<sub>imp</sub></b>	(DC+ $\Rightarrow$ DC-)	<b>12.5 kA</b>	<b>12.5 kA</b>
	(DC+/DC- $\Rightarrow$ PE)	<b>12.5 kA</b>	<b>12.5 kA</b>
Voltage protection level U <sub>p</sub>	(DC+ $\Rightarrow$ DC-)	< 2.4 kV	< 2.9 kV
	(DC+/DC- $\Rightarrow$ PE)	< 2.4 kV	< 2.9 kV
Response time t <sub>A</sub>	< 25 ns		
Cross section for connection	min. 4 mm <sup>2</sup> single-core/ finely-stranded max. 50 mm <sup>2</sup> stranded / 35 mm <sup>2</sup> finely-stranded		

**Note:** The product series P-HYS is specially designed for the use in the DC side of photovoltaic systems.  
The maximum continuous operating voltage U<sub>CPV</sub> of the device shall be selected to be always higher than the maximum open circuit voltage of the PV-generator!

### P-HYS R PV



Ord. no. 317 761



Ord. no. 317 705

Basic circuit diagram:

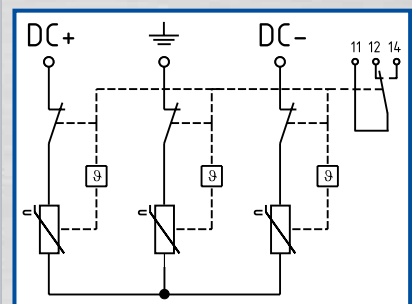



## Combined lightning current and surge arrester P-HYS 1000/1500 1(2) BOX **NEW!** for photovoltaic systems, type 1+2

### Benefits:

- Compact pre-assembled surge arrester for photovoltaic systems
- P-HYS 1500 1 (2) BOX usable for a max. continuous operating voltage up to 1500 V
- P-HYS 1000 (1500) 2 BOX for protecting two MPP trackers.
- Suitable for PV-systems with earthed plus or minus pole.
- Push-In terminal block for fast connection without tools
- Suitable for indoor and outdoor use
- Optimal price/performance ratio

### P-HYS 1000/1500 1(2) **NEW!**



Ord. no. 317 711



Ord. no. 317 752

Basic circuit diagram:

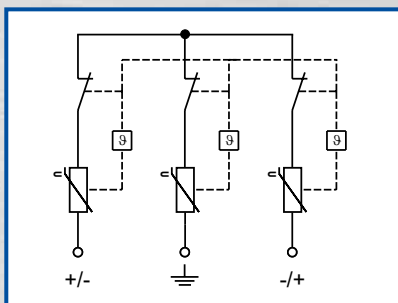

### P-HYS 1000/1500 1(2) BOX, (class I+II)//BSZ 0<sub>A</sub>-BSZ 2

Combined lightning current and surge arrester with 1 MPP-Tracker		Ord. no.
Type		
P-HYS 1000 1 BOX		317 711
P-HYS 1500 1 BOX		317 751
Combined lightning current and surge arrester with 2 MPP-Trackers		Ord. no.
Type		
P-HYS 1000 2 BOX		317 712
P-HYS 1500 2 BOX		317 752

Technical data					
Type P-HYS		1000 1	1500 1	1000 2	1500 2
SPD		Typ 1+2			
<b>Max. continuous operating voltage (DC) <math>U_{CPV}</math></b>		<b>1100 V</b>	<b>1500 V</b>	<b>1100 V</b>	<b>1500 V</b>
Nom. discharge current (8/20 $\mu$ s)	$I_n$	20 kA			
	$I_{total}$	50 kA			
Max. discharge current (8/20 $\mu$ s)	DC+ $\Rightarrow$ DC-	40 kA	50 kA	40 kA	50 kA
$I_{max}$	DC+/DC- $\Rightarrow$ PE				
	Total $\Rightarrow$ PE				
Lightning impulse current (10/350 $\mu$ s)	$I_{imp}$	<b>6.25 kA</b>			
	$I_{total}$	<b>12.5 kA</b>			
Voltage protection level $U_p$	DC+ $\Rightarrow$ DC-	< 4.4 kV	< 5.2 kV	< 4.4 kV	< 5.2 kV
	DC+/DC- $\Rightarrow$ PE				
Rated Load Current $I_L$		35 A			
Response time $t_A$		< 25 ns			
Number of MPP-Trackers		1	1	2	2
Mounting type		Wall installation			
Protection class		IP65			
Connecting type		Push-In			
Outside diameter of the conductor		4 mm (min)   8 mm (max) (stranded, finely stranded)			
Conductor cross-section (cable gland)		0.2 mm <sup>2</sup> (min)   16 mm <sup>2</sup> (max) (stranded, finely stranded)			
Dimensions L x W x H (mm)		160 x 120 x 91			

**Note:** The product series P-HYS BOX is specially designed for the use in the DC side of photovoltaic systems.  
The maximum continuous operating voltage  $U_{CPV}$  of the device shall be selected to be always higher than the maximum open circuit voltage of the PV-generator!

## Surge arrester for photovoltaic systems, type 2

- Benefits:**
- Safe fixation and contact ensured by module locking mechanism.
  - Min. cross section for connection 4 mm<sup>2</sup>

### P-VYS (Fm) R PV, (class II)//LPZ 1-LPZ 2

#### Surge arrester, pluggable

Type		Ord. no.
P-VYS 605 R PV	Y-circuit	<b>316 762</b>
P-VYS 805 R PV	Y-circuit	<b>316 782</b>
P-VYS 1005 R PV	Y-circuit	<b>316 792</b>

#### Surge arrester, pluggable with remote signalling contact (Fm)

Type		Ord. no.
P-VYS 605 Fm R PV	Y-circuit	<b>316 766</b>
P-VYS 805 Fm R PV	Y-circuit	<b>316 786</b>
P-VYS 1005 Fm R PV	Y-circuit	<b>316 796</b>

#### Technical data

Type P-VYS (Fm) R PV	605	805	1005
Dimensions	3 mods.	3 mods.	3 mods.
<b>Max. continuous operating voltage <math>U_{CPV}</math></b>	<b>600 V-</b>	<b>800 V-</b>	<b>1000 V-</b>
Nominal discharge current (8/20 $\mu$ s) $I_n$	DC+ $\Rightarrow$ DC-	20 kA	
	DC+/DC- $\Rightarrow$ PE	20 kA	
	total $\Rightarrow$ PE	30 kA	
Max. discharge current (8/20 $\mu$ s) $I_{max}$	DC+ $\Rightarrow$ DC-	40 kA	
	DC+/DC- $\Rightarrow$ PE	40 kA	
	total $\Rightarrow$ PE	60 kA	
Voltage protection level $U_p$	DC+ $\Rightarrow$ DC-	< 2.5 kV	< 3.5 kV
	DC+/DC- $\Rightarrow$ PE	< 1.7 kV	< 2.0 kV
Response time $t_A$	< 100 ns		
Cross section for connection	min. 4 mm <sup>2</sup> single-core/ finely stranded max. 50 mm <sup>2</sup> stranded / 35 mm <sup>2</sup> finely-stranded		

**Note:** This product series is specially designed for the use in the DC side of **not earthed PV-systems** (not earthed plus or minus pole).  
The maximum continuous operating voltage  $U_{CPV}$  of the device shall be selected to be always higher than the maximum open circuit voltage of the PV-generator!

### P-VYS R PV



Ord. no. 316 766

#### Basic circuit diagram:

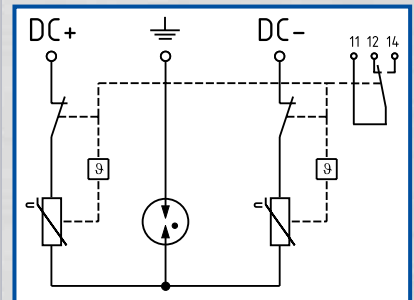



## Surge arrester for photovoltaic systems, type 2

- Benefits:**
- Safe fixation and contact ensured by module locking mechanism.
  - Optimal price-performance ratio.
  - Suitable for PV-systems with earthed plus or minus pole.
  - Min. cross section for connection 4 mm<sup>2</sup>

### P-VYS R PV



Ord. no. 316 761

Basic circuit diagram:

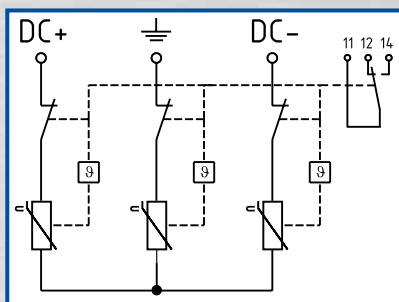

### P-VYS (Fm) R PV, (class II)//LPZ 1-LPZ 2

#### Surge arrester, pluggable

Type		Ord. no.
P-VYS 300 R PV	Y-circuit	316 741
P-VYS 600 R PV	Y-circuit	316 761
P-VYS 800 R PV	Y-circuit	316 781
P-VYS 1000 R PV	Y-circuit	316 701

#### Surge arrester, pluggable with remote signalling contact (Fm)

Type		Ord. no.
P-VYS 300 Fm R PV	Y-circuit	316 745
P-VYS 600 Fm R PV	Y-circuit	316 765
P-VYS 800 Fm R PV	Y-circuit	316 785
P-VYS 1000 Fm R PV	Y-circuit	316 705

#### Technical data

Type P-VYS (Fm) R PV	300	600	800	1000
Dimensions	3 mods.	3 mods.	3 mods.	3 mods.
<b>Max. continuous operating voltage <math>U_{CPV}</math></b>	<b>300 V-</b>	<b>600 V-</b>	<b>800 V-</b>	<b>1000 V-</b>
Nominal discharge current (8/20 $\mu$ s) $I_n$		20 kA	20 kA	
Max. discharge current (8/20 $\mu$ s) $I_{max}$		40 kA	40 kA	
Voltage protection level $U_p$	(DC+ $\Rightarrow$ DC-) < 1.3 kV	(DC+ / DC- $\Rightarrow$ PE) < 2.5 kV	< 3.0 kV	< 3.5 kV
Response time $t_A$	< 25 ns			
Cross section for connection	min. 4 mm <sup>2</sup> single-core/ finely stranded max. 50 mm <sup>2</sup> stranded / 35 mm <sup>2</sup> finely-stranded			

**Note:** The product series P-VYS is specially designed for the use in the DC side of photovoltaic systems.  
The maximum continuous operating voltage  $U_{CPV}$  of the device shall be selected to be always higher than the maximum open circuit voltage of the PV-generator!

## Surge arrester P-VYS 1000/1500 1(2) BOX NEW! for photovoltaic systems, type 2

### Benefits:

- Compact pre-assembled surge arrester for photovoltaic systems
- P-VYS 1500 1 (2) BOX usable for a max. continuous operating voltage up to 1500 V
- P-VYS 1000 (1500) 2 BOX for protecting two MPP trackers.
- Suitable for PV-systems with earthed plus or minus pole.
- Push-In terminal block for fast connection without tools
- Suitable for indoor and outdoor use
- Optimal price/performance ratio

### P-VYS 1000/1500 1(2) BOX, (class II)//BSZ 1-BSZ 2

#### Surge arrester with 1 MPP-Tracker

Type	Ord. no.
P-VYS 1000 1 BOX	316 711
P-VYS 1500 1 BOX	316 751

#### Surge arrester with 2 MPP-Trackers

Type	Ord. no.
P-VYS 1000 2 BOX	316 712
P-VYS 1500 2 BOX	316 752

#### Technical data

Type P-VYS	1000 1	1500 1	1000 2	1500 2
SPD	Typ 2			
<b>Max. continuous operating voltage (DC) <math>U_{CPV}</math></b>	<b>1100 V</b>	<b>1500 V</b>	<b>1100 V</b>	<b>1500 V</b>
Nominal discharge current (8/20 $\mu$ s) $I_n$	20 kA	15 kA	20 kA	15 kA
Max. discharge current (8/20 $\mu$ s) $I_{max}$	40 kA			
Voltage protection level $U_p$	DC+ $\Rightarrow$ DC-	< 4.2 kV	< 4.8 kV	< 4.2 kV
	DC+/DC- $\Rightarrow$ PE	< 4.2 kV	< 4.8 kV	< 4.8 kV
Rated Load Current $I_L$	35 A			
Response time $t_A$	< 25 ns			
Number of MPP-Trackers	1	1	2	2
Mounting type	Wall installation			
Protection class	IP65			
Connecting type	Push-In			
Outside diameter of the conductor	4 mm (min)   8 mm (max) (stranded, finely stranded)			
Conductor cross-section (cable gland)	0.2 mm <sup>2</sup> (min)   16 mm <sup>2</sup> (max) (stranded, finely stranded)			
Dimensions L x W x H:	160 x 120 x 91 mm			

**Note:** The product series P-VYS BOX is specially designed for the use in the DC side of photovoltaic systems.  
The maximum continuous operating voltage  $U_{CPV}$  of the device shall be selected to be always higher than the maximum open circuit voltage of the PV-generator!

### P-VYS 1000/1500 1 (2) NEW!



Best.Nr. 316 711



Best.Nr. 316 752

#### Basic circuit diagram:

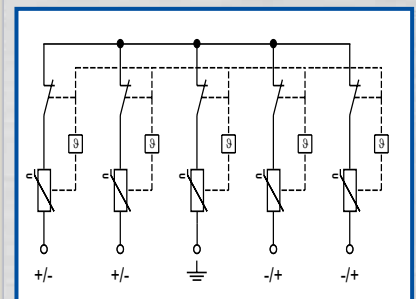



## Surge arrester for high-frequency signal circuits

P-1(2)SQ HF, LPZ 0 - LPZ 3

Differential mode protection for LPZ 0 - 3		$U_N$	Ord. no.
P-1 SQ 5 HF	1 signal circuit	5 V-	230 105
P-1 SQ 24 HF	1 signal circuit	24 V-	230 124
P-2 SQ 5 HF	2 signal circuits	5 V-	230 605
P-2 SQ 24 HF	2 signal circuits	24 V-	230 624

Technical data		
Type P-1 (2)	SQ 5 HF	SQ 24 HF
Nominal voltage $U_N$	5 V-	24 V-
Max. continuous operating voltage $U_C$	7 V- 4.9 V~	30 V- 21.2 V~
C3 Voltage protection level at 1 kV/ $\mu$ s $U_p$	line-line	< 12 V
	line-PE	< 550 V
C2 Voltage protection level at 10 kA $U_p$	line-line	< 55 V
	line-PE	< 800 V
C2 Voltage protection level at 5 kA $U_p$	line-line	< 35 V
	line-PE	< 650 V
Nominal current		0.8 A
C2 Nominal discharge current (8/20 $\mu$ s) $I_n$	per pair	10 kA
D1 Lightning impulse current (10/350 $\mu$ s) $I_{imp}$	per pair	5 kA
Response time $t_A$		1 ns
Line resistance		1.0 $\Omega$
Cut-off frequency $f_g$		100 MHz
Cross section for connection		0.14 - 2.5 mm <sup>2</sup>
Test category according to EN 61643-21		C1, C2, C3, D1
Housing material		Thermoplast, UL 94 V-0, colour orange

**Note:** Surge arrester for earth-potential free signal circuits

P-1 SQ 5 HF



Ord. no. 230 105

P-2 SQ 24 HF



Ord. no. 230 624

Basic circuit diagram P-1 SQ HF:

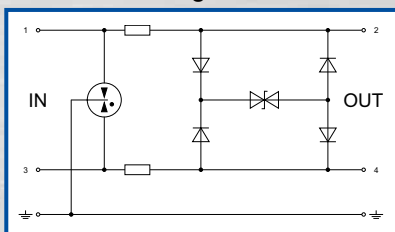

Basic circuit diagram P-2 SQ HF:

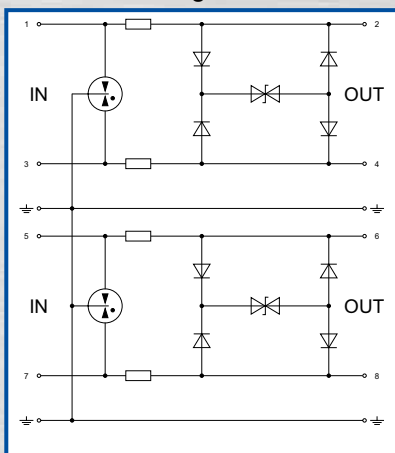

### Design:

#### Signal circuit

P-1 1 signal circuit

P-2 2 signal circuit

#### Basic protection (LPZ 0 - LPZ 1)

P-  S signal circuit basic protection

#### Basic protection + fine protection for (LPZ 0 - LPZ 3)

P-  SQ differential mode protection line/line

P-  SQL differential and common mode protection line/line + line/PE

#### High-frequency

P-  HF with high cut-off frequency

#### General:

P-  E Surge arrester with DIN rail earthing

SPD earthed by snapping onto 35 mm DIN rail (according to EN 60715) on request.





## Surge arrester for information, measurement and control technology

### P-1(2) SQ, LPZ 0 - LPZ 3

Type for analogue telephone lines		$U_N$	Ord. no.
P-1 SQ 110	1 signal circuit	110 V~	220 194
P-2 SQ 110	2 signal circuits	110 V~	220 694
Differential mode protection for LPZ 0 - 3		$U_N$	Ord. no.
P-1 SQ 5	1 signal circuit	5 V-	220 105
P-1 SQ 12	1 signal circuit	12 V-	220 112
P-1 SQ 24	1 signal circuit	24 V-	220 124
P-1 SQ 48	1 signal circuit	48 V-	220 148
P-1 SQ 60	1 signal circuit	60 V-	220 160
P-2 SQ 5	2 signal circuits	5 V-	220 605
P-2 SQ 12	2 signal circuits	12 V-	220 612
P-2 SQ 24	2 signal circuits	24 V-	220 624
P-2 SQ 48	2 signal circuits	48 V-	220 648
P-2 SQ 60	2 signal circuits	60 V-	220 660

#### Technical data

Type P-1 (2)	SQ 5	SQ 12	SQ 24	SQ 48	SQ 60	SQ 110
Nominal voltage $U_N$	5 V-	12 V-	24 V-	48 V-	60 V-	110 V~
Max. continuous operating voltage $U_C$	6 V- 4.5 V~	15 V- 10.5 V~	33.3 V- 23.5 V~	58 V- 41 V~	70 V- 50 V~	170 V- 120 V~
C3 Voltage protection level at 1 kV/ $\mu$ s $U_p$	line-line	< 9 V	< 20 V	< 45 V	< 75 V	< 90 V
	line-PE	< 550 V				
C2 Voltage protection level at 10 kA $U_p$	line-line	< 15 V	< 28 V	< 48 V	< 85 V	< 105 V
	line-PE	< 700 V				
Nominal current	0.75 A					
C2 Nominal discharge current (8/20 $\mu$ s) $I_n$	total	20 kA				
	per line	10 kA				
D1 Lightning impulse current (10/350 $\mu$ s) $I_{imp}$	total	5 kA				
	per line	2.5 kA				
Response time $t_A$	1 ns					
Line resistance	2.2 $\Omega$					
Cut-off frequency $f_g$	1.2 MHz	3.2 MHz	6 MHz	9.2 MHz	12 MHz	23 MHz
Cross section for connection	0.14 - 2.5 mm <sup>2</sup>					
Test category according to EN 61643-21	C1, C2, C3, D1					
Housing material	Thermoplast, UL 94 V-0, colour orange					

**Note:** Surge arrester for earth-potential free signal circuits

Basic circuit diagram P-1 SQ:

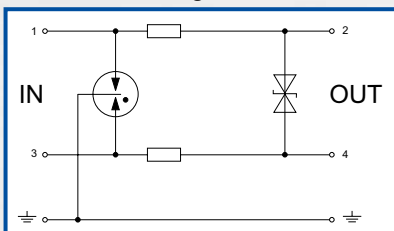

Basic circuit diagram P-2 SQ:

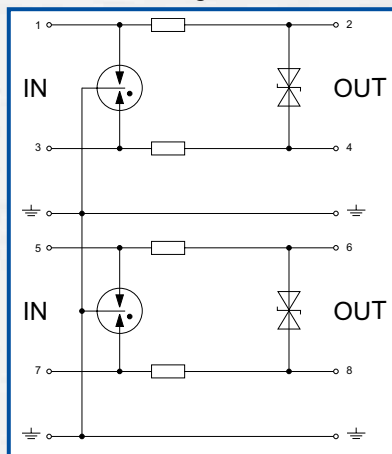

### P-1 SQ 110



Ord. no. 220 194

### P-2 SQ 24



Ord. no. 220 624



## Surge arrester for information, measurement and control technology

### P-1 S



Ord. no. 220 000

### P-2 SQL 12



Ord. no. 220 712

Basic circuit diagram P-1 S

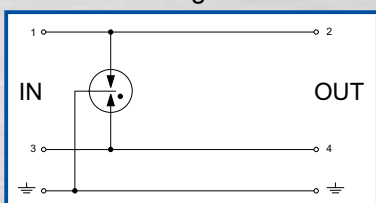

Basic circuit diagram P-2 S

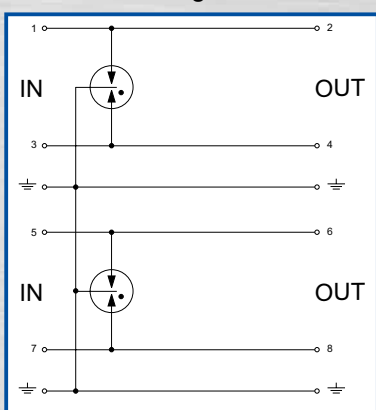

### P-1(2) S, LPZ 0 - LPZ 1 and P-1(2) SQL, LPZ 0 - LPZ 3

Signal circuit - basic protection for LPZ 0 - 1		$U_N$	Ord. no.
P-1 S	1 signal circuit	110 V~	220 000
P-2 S	2 signal circuits	110 V~	220 500
Differential and common mode protection for LPZ 0 - 3		$U_N$	Ord. no.
P-1 SQL 5	1 signal circuit	5 V-	220 205
P-1 SQL 12	1 signal circuit	12 V-	220 212
P-1 SQL 24	1 signal circuit	24 V-	220 224
P-1 SQL 48	1 signal circuit	48 V-	220 248
P-1 SQL 60	1 signal circuit	60 V-	220 260
P-2 SQL 5	2 signal circuits	5 V-	220 705
P-2 SQL 12	2 signal circuits	12 V-	220 712
P-2 SQL 24	2 signal circuits	24 V-	220 724
P-2 SQL 48	2 signal circuits	48 V-	220 748
P-2 SQL 60	2 signal circuits	60 V-	220 760

Technical data						
Type P-1 (2)	SQL 5	SQL 12	SQL 24	SQL 48	SQL 60	S
Nominal voltage $U_N$	5 V-	12 V-	24 V-	48 V-	60 V-	110 V~
Max. continuous operating voltage $U_C$	6 V-	15 V-	33.3 V-	58 V-	70 V-	180 V-
	4.5 V~	10.5 V~	23.5 V~	41 V~	50 V~	130 V~
C3 Voltage protection level at 1 kV/ $\mu$ s $U_p$	line-line	< 20 V	< 45 V	< 75 V	< 90 V	< 650 V
	line-PE	< 9 V	< 20 V	< 45 V	< 75 V	< 550 V
C2 Voltage protection level at 10 kA $U_p$	line-line	< 28 V	< 48 V	< 85 V	< 105 V	< 900 V
	line-PE	< 20 V	< 40 V	< 55 V	< 100 V	< 700 V
Nominal current	0.75 A					10 A
C2 Nominal discharge current (8/20 $\mu$ s) $I_n$	total	20 kA				
	per line	10 kA				
D1 Lightning impulse current (10/350 $\mu$ s) $I_{imp}$	total	5 kA				
	per line	2.5 kA				
Response time $t_A$	1 ns					100 ns
Line resistance	2.2 $\Omega$					-
Cut-off frequency $f_g$	0.8 MHz	2 MHz	4 MHz	7.5 MHz	8.7 MHz	200 MHz
Cross section for connection	0.14 - 2.5 mm <sup>2</sup>					
Test category acc. to EN 61643-21	C1, C2, C3, D1					
Housing material	Thermoplast, UL 94 V-0, colour orange					

Basic circuit diagram P-1 SQL

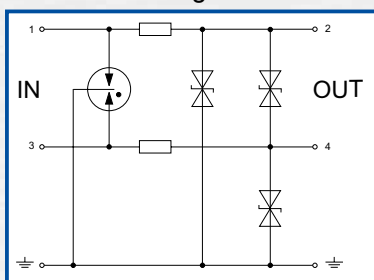

Basic circuit diagram P-2 SQL

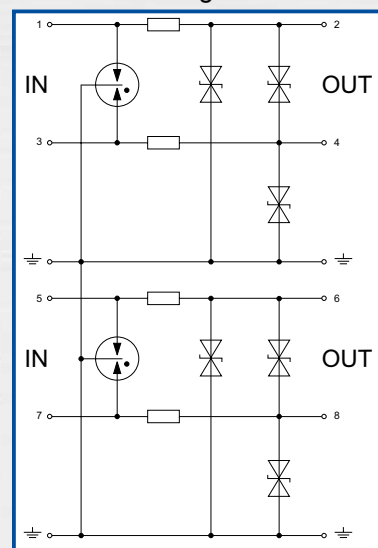

## Combined arrester P-HF BOX

- Benefits:**
- Compact design
  - Quick and easy installation by surface-mounted box
  - Protection class IP 65
  - Universally usable surge arrester for different telecommunication interfaces, such as VoIP.
  - Cut-off frequency up to 250 MHz
  - Push-In terminal block for fast connection without tools (simple, push-in terminations of solid and ferruled conductors)
  - High discharge capacity up to 2.5 kA (10/350  $\mu$ s) per line

**P-HF BOX**, combined arrester in a surface-mounted enclosure specially designed for the use in telecommunications interfaces. LPZ 0-LPZ 3

Combined lightning current and surge arrester type	Ord. no.
P-HF BOX	210 090

### Technical data: Type P-HF BOX

SPD class	D1 + C2
Max. continuous voltage $U_{c,ac}$	125 V
Max. continuous voltage $U_{c,dc}$	180 V
<b>Lightning impulse current (10/350 <math>\mu</math>s) / per line <math>I_{imp}(D1)</math></b>	<b>2.5 kA</b>
<b>Lightning impulse current (10/350 <math>\mu</math>s) / total <math>I_{imp}(D1)</math></b>	<b>7.5 kA</b>
Nominal discharge current (8/20 $\mu$ s) / per line $I_n(C2)$	7.5 kA
Nominal discharge current (8/20 $\mu$ s) / total $I_n(C2)$	15 kA
Nominal current $I_l$	0.75 A
Voltage protection level $U_p$ - Line-Line	< 350 V
Voltage protection level $U_p$ - Line-PE	< 550 V
Cut-off frequency < 3 dB	250 MHz
Series resistance per line	1.8 $\Omega$
Capacitance - Line-Line	< 20 pF
Capacitance - Line-PE	< 20 pF
Mounting type	Surface-mounted
Dimensions LxWxH (mm)	93x93x55
Protection class	IP 65
Operating temperature range	-25°C up to +40°C
Connecting type	Push-In
Cross section for connection	0.20 - 1.5 mm <sup>2</sup> Signal line 0.25 - 2.5 mm <sup>2</sup> Earth terminal
Cable relief and fixing of conductors	Cable tie

## P-HF BOX



Ord. no. 210 090

## Communication protection in LSA-plus technology

Plug-in type surge arresters for communication systems, designed as terminal block and disconnection block with LSA-plus insulation displacement technology (soldering, screwing and strip-free connection technology).

### P-LSA-plus-technology

Type	Max. continuous operating voltage $U_c$	PU	Ord. no.
Gas discharge tube for magazine P-LSA/MU			
P-LSA/GA 75	75 V	10	240 350
P-LSA/GA 90	90 V	10	240 351
P-LSA/GA 150	150 V	10	240 352
P-LSA/GA 230	230 V	10	240 353
Combined arrester for direct plug-in at the disconnection block P-LSA/TL			
P-LSA/KA 180	180 V	1	240 451
Magazine (unequipped) for gas discharge tube P-LSA/GA			
P-LSA/MU		1	240 300
Cover for P-LSA/MU			
P-LSA/MAD		1	240 309
P-LSA/EB - Earthing clip		1	240 190
P-LSA/TL - Disconnection block for mounting on LSA mounting frame		1	240 200
P-LSA/AL - Terminal block for mounting on LSA mounting frame		1	240 250
P-LSA/MB- for 10 LSA-plus disconnection or terminal blocks Type P-LSA/TL or P-LSA/AL		1	240 100

## P-LSA/GA



Ord. no. 240 351

## P-LSA/KA 180



Ord. no. 240 451

## P-LSA/MU



Ord. no. 240 300



## P-TK/AN



Ord. no. 210 012

## P-TK/Z-CAT 6 A



Ord. no. 210 140

## P-KNX



Ord. no. 210 160

## P-TK/Z-SAT



Ord. no. 210 210

## P-TKF/Z-SAT



Ord. no. 210 212

## Communication and network protection

P-TK/AN surge arrester for analogue telephone lines, (LPZ 0<sub>B</sub>-LPZ 3)

Type	Ord. no.
P-TK/AN	210 012
<b>Technical data: Type P-TK/AN</b>	
Max. continuous operating voltage U <sub>C</sub>	120 V~ / 170 V-
Nominal discharge current (8/20 μs) I <sub>n</sub>   line-PE	5.0 kA
Voltage protection level U <sub>p</sub>   line-line	≤ 300 V
Temperature range θ	-20°C up to +60°C
Connection	LSA Plus terminal strip
Dimensions LxWxH (mm)	41.5x44.5x15

P-TK/Z-CAT 5, -CAT 6 S, (LPZ 0<sub>B</sub>-LPZ 3)

Type	Ord. no.
P-TK/Z-CAT 5   Including network patch cable	210 110
P-TK/Z-CAT 6 S   Including network patch cable	210 130
P-TK/Z-CAT 6 A   Including network patch cable	210 140

Technical data			
Type P-TK/Z	-CAT 5	-CAT 6 S	-CAT 6 A
Max. continuous operating voltage U <sub>C</sub>	6 V~ 8.5 V-	---	---
Nominal current I <sub>L</sub>	500 mA	500 mA	500 mA
Nominal discharge current (8/20 μs) I <sub>n</sub>   line-PE	1.6 kA	1.6 kA	10 kA
Voltage protection level U <sub>p</sub>   line-line	< 40 V	< 130 V	< 90 V
Transmission rate	1 Gbit/s		10 Gbit/s
Response time t <sub>A</sub>	< 1 ns		
Connection	2x RJ 45		
Dimensions LxWxH (mm)	90x25x47		

P-KNX<sub>y</sub> (BSZ 0<sub>B</sub>-BSZ 3)

Type	Ord. no.
P-KNX	210 160

Technical data	
Typ P-KNX	
Nominal voltage U <sub>N</sub>	24 V AC
Nominal current at 25 °C I <sub>L</sub>	7 A
Nominal discharge current (8/20 μs) I <sub>n</sub>	5 kA
Voltage protection level U <sub>p</sub>   line-line	< 1000 V
line-PE	< 600 V
Response time t <sub>A</sub>	< 100 ns
Cut-off frequency f <sub>g</sub>	50 MHz
Length of connection cable	200 mm

Coax surge protection devices P-TK/Z and P-TKF/Z

Type basic protection; LPZ 0 <sub>A</sub> - LPZ 1	Ord. no.
P-TK/Z-SAT	210 210
P-TK/Z-BNC 75	210 228
Type fine protection; LPZ 2 - LPZ 3	
P-TKF/Z-SAT	210 212

Technical data			
Type	P-TK/Z-SAT	P-TK/Z-BNC 75	P-TKF/Z-SAT
Max. continuous operating voltage U <sub>C</sub>	70 V-	70 V-	29.1 V-
Nominal current I <sub>L</sub>	4 A		
Lightning impulse current (10/350 μs) I <sub>imp</sub>	2.5 kA	/	
Nominal discharge current (8/20 μs) I <sub>n</sub>	10 kA	1.5 kA	
Voltage protection level U <sub>p</sub>   line / PE	< 600 V	< 80 V	
Response time t <sub>A</sub>	< 100 ns		
Wave impedance Z	75 Ω		
Frequency range f	< 2.15 GHz	< 2.15 GHz	1 MHz-2.15 GHz
Connection	2x F-socket	2x BNC-socket	2x F-socket
Dimensions LxWxH (mm)	45x25x47	45x25x47	45x25x47
Test standard	EN 61643-21		



## Accessories

### Busbars

for multipole connection of lightning current and surge arresters.

Specification	Fit	Length	PU	Ord. no.
Copper with plastic strip	16 mm <sup>2</sup>	1 m	1	<b>206 060</b>
2 mods. with integrated end cap	16 mm <sup>2</sup>	36 mm	1	<b>206 062</b>
3 mods. with integrated end cap	16 mm <sup>2</sup>	54 mm	1	<b>206 063</b>
4 mods. with integrated end cap	16 mm <sup>2</sup>	72 mm	1	<b>206 064</b>
6 mods. with integrated end cap	16 mm <sup>2</sup>	108 mm	1	<b>206 065</b>

**Earth-side bridging bar**, for the bridging of earthing terminals for 2, 3 or 4 single-pole lightning current and surge arresters.

Specification	PU	Ord. no.
Brass / tinned	1	<b>2064</b>
With terminal clamp 25 mm <sup>2</sup>		
2-pole to 4-pole		
Earthing terminals for the connection of an additional protective conductors up to 35 mm <sup>2</sup>	1	<b>207 000</b>

**Distribution board** grey, degree of protection IP 65, as insulation material housing for lightning current and surge arresters.

Housing Typ	Dimensions (W x H x T)	PU	Ord. no.
KV 3 TE (3 mods.)	100 x 150 x 96 mm	1	<b>206 010</b>
KV 5 TE (5 mods.)	125 x 200 x 122 mm	1	<b>206 005</b>
KV 9 TE (9 mods.)	200 x 200 x 122 mm	1	<b>206 004</b>
KV 12 TE (12 mods.)	250 x 200 x 122 mm	1	<b>206 011</b>

Other housing dimensions on request.

### Spare parts

Plug-in - type	Housing colour	Ord. no.
P-HMS 280	red	<b>207 201</b>
P-HMS 280 Fm	red	<b>207 203</b>
P-HMS 360	red	<b>207 301</b>
P-HMS 360 Fm	red	<b>207 303</b>
P-HMS 440	red	<b>207 401</b>
P-HMS 440 Fm	red	<b>207 403</b>
P-HMS 280	blue	<b>307 201</b>
P-HMS 300 PV	blue	<b>307 201 PV</b>
P-HMS 280 Fm	blue	<b>307 203</b>
P-HMS 300 Fm PV	blue	<b>307 203 PV</b>
P-VMS 280	red	<b>206 281</b>
P-VMS 280 Fm	red	<b>206 283</b>
P-VMS 360	red	<b>206 364</b>
P-VMS 360 Fm	red	<b>206 366</b>
P-VMS 440	red	<b>206 442</b>
P-VMS 440 Fm	red	<b>206 444</b>
P-VMS 280	blue	<b>306 281</b>
P-VMS 300 PV	blue	<b>306 281 PV</b>
P-VMS 280 Fm	blue	<b>306 283</b>
P-VMS 300 Fm PV	blue	<b>306 283 PV</b>
P-HMS 280 R	blue	<b>317 201</b>
P-HMS 280 <i>max</i>	blue	<b>317 206</b>
P-VMS 280 R	blue	<b>316 281</b>
P-HMS 280 G	blue	<b>327 201</b>

**Additional spare parts on request.**

### Busbars

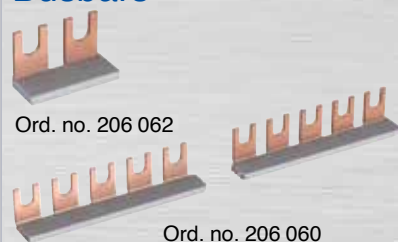

Ord. no. 206 062

Ord. no. 206 060

### Earthing terminals



Ord. no. 2064

Ord. no. 207 000

### Distribution boards



Ord. no. 206 005

### Spare parts



Ord. no. 207 201

Ord. no. 307 201

Ord. no. 206 281

Ord. no. 317 206



## Keyword register

Air termination poles, for block foundation	62	KS-connectors	91/122
Air termination poles, for wall mounting	58-59	Multi-clamps	89
Air termination poles, free-standing	54-56	Multi-Plus-clamps	88/98
Air termination rods	43-44/47-49/51	Niro-Clip	64-66
Air termination stud	50	Number plates	106
Air termination tip	50	Plastic conductor fastener	66
Bimetal clamp	102/103	Plastic spacer	67
Bimetal Multi-clamps	89/102	Plastic washers	67
Bimetallic bush and strip	102	Protective spark gaps	175
Bridging brackets	105	Rod holder	70
Bridging braids	105	Roof bushing	80
Bridging cables	105	Roof conductor holder	72-80/82
Cables	38	Roof conductor holder for ridge tiles	72-77/80/81
Clamping jaws	91	Round wires	39
Clamping shoe	104	Saddle clamps	98/99
Combined lightning current and surge arresters type 1+2	178-181	Screw cap conductor fasteners	66
Concrete bases	44-46/54	Screws	174
Conductor	38	Snow guard clamps	106
Conductor fastener	64-66/68	Spring lock washers	174
Connection clamp	90-92	Straightening tools	173
Corrosion prevention tape	174	Strips	38
Cross clamps	118	Surge arrester for PV	186-191
Cross profiled earth rod	111	Surge arrester type 2	182
Diagonal-cross clamps	112	Surge arrester type 2+3	183/184
Disconnecting clamps	94-97	Surge arrester type 3	185
Downpipe clamps	69/107	Surge arresters for information, measurement and control technology	195-196
Driving heads	120	Tape conductor holder	121
Driving steel darts	119	Telescope air termination pole	56/58
Earth electrode inspection housing	108	Terminal angles	92
Earth lead-in rods	111	Terminal clamps	100/101/119
Earth rods	119	Test joint boxes	108
Earthing pipe clamps	121-122	Tubular earth rod	119
Earth testers	176	Uncoiling units	172
Equipotential bonding	132-134	USV-clamp	112
Expansion pieces	105	Vario-clamp	96/97
Fasteners	67	Wall bushings	125/126
Fixed earthing terminals	123-126	Wall conductor fasteners	64-68/70/71
Fixed earthing terminals with DB-approval	128/129	Wedge connectors	118
Gutter clamp	104		
HVC	147-170		
Inspection doors	107		
Insulated air termination poles	136-137/139		
Insulated stand-offs	140-144		
Isolating spark gap	175		



# Test requirements for lightning protection components according to EN 62561

Document	Description	Legend	Classification	Document	Description	Legend	Classification	
Part 1	Requirements for connection components	①	H / N	Part 5	Requirements for earth electrode inspection housings and earth electrode seals	⑤		
Part 2	Requirements for conductors and earth electrodes	②		Part 7	Requirements for earthing enhancing compounds	⑦		
Part 3	Requirements for isolating spark gaps	③		Part 8	Requirements for an isolated lightning protection system	⑧	H2 / H1 / H / N	
Part 4	Requirements for conductor fasteners	④		Shortcircuit current (50Hz) (1s; ≤300°C) in kA		$I_k$		
Requirements and test methods for surge protection device			Energy technology EN 61643-11				E	
			Photovoltaics EN 50539-11				P	
			Information technology EN 61643-21				I	

## Numerical index

Ord. no.	Tested	$I_k$	Page	Ord. no.	Tested	$I_k$	Page	Ord. no.	Tested	$I_k$	Page
1010	④	-	66	1236	-	-	138	1314	①/H	-	104
1011	④	-	66	1237	-	-	138	1315	①/H	-	104
1014	④	-	66	1240	①/H	-	122	1319	-	-	110
1015	④	-	66	1241	①/H	-	122	1320	①/N	-	118
1024	-	-	174	1242	①/H	-	122	1320 S	①/H	-	118
1025	-	-	174	1243	①/H	-	122	1321	-	-	110
1027	④	-	72	1244	①/H	-	122	1321 S	-	-	110
1028	④	-	72	1245	①/H	-	122	1322	①/H	-	118
1031	④	-	68	1246	①/H	-	122	1323	①/H	-	118
1032	④	-	68	1247	①/H	-	122	1324	①/H	-	118
1033	④	-	68	1248	①/H	-	122	1325	①/H	-	118
1034	④	-	68	1249	①/H	-	122	1326	①/H	-	118
1035	④	-	68	1250	②	-	47	1327	①/H	-	118
1036	④	-	68	1251	②	-	47	1327 S	①/H	-	118
1037	④	-	68	1252	-	-	50	1329	①/H	-	118
1040	-	-	107	1253	-	-	50	1330	①/H	-	94
1041	-	-	107	1254	②	-	47	1331	①/H	-	94
1042	-	-	67	1254 S1	④	-	47	1332	①/H	-	94
1042 S	-	-	93	1254 S2	②	-	47	1333	①/H	-	94
1043	①/N;⑤	-	108	1254 S3	④	-	47	1334	①/N	-	98
1043 S1	①/N;⑤	-	108	1255	②	-	47	1335	①/N	-	98
1044	-	-	107	1255 S2	②	-	47	1336	①/N	-	98
1045	-	-	107	1257	②	-	51	1337	①/H	-	96
1046	-	-	67	1257 S	②	-	51	1339	①/H	-	96
1046 S	-	-	93	1259	②	-	51	1340	①/H	-	96
1047	-	-	67	1259 S	②	-	51	1341	①/H	-	96
1048	-	-	67	1261	①	-	98	1342	①/H	-	96
1049	-	-	173	1262	①	-	98	1342 Z	①/H	-	96/102
1051	-	-	102	1263	①	-	98	1343	①/H	-	96
1052	-	-	102	1264	①/N	-	98	1343 Z	①/H	-	96/102
1053	-	-	102	1265	①	-	98	1344	①/H	-	96
1054	-	-	107	1266	①	-	98	1345	①/H	-	96
1055	⑤	-	108	1270	①/H	-	89	1346	①/H	-	96
1055 S1	⑤	-	108	1270 S3	①/H	-	122	1347	①/H	-	96
1056	-	-	106	1271	①/H	-	89	1348 Z	①/H	-	96/102
1059	-	-	106	1271 S	①/H	-	122	1349 Z	①/H	-	96/102
1060	-	-	106	1272	①/H	-	89	1354	①/H	-	112
1062	④	-	74	1273	①/H	-	89	1359	①/H	-	91/122
1063	④	-	74	1273 S1	①/H	-	122	1360	①/H	-	91/122
1064	④	-	74	1274	①/H	-	89/102	1361	①/H	-	91/122
1065	④	-	74	1275	①/H	-	89	1362	①/H	-	91/122
1066	④	-	74	1276	①/H	-	89	1363	①/H	-	92
1067	④	-	74	1277	①/H	-	89	1364	①/H	-	92
1068	-	-	174	1278	①/H	-	89/112	1365	①	-	104
1069	-	-	174	1279	①/H	-	89/112	1366	①/H	-	92
1088	④	-	76	1279 S	①/H	-	89/112	1367	①/H	-	92
1095	④	-	76	1280	①/H	-	91	1368	①/H	-	92
1121	④	-	71	1281	①/N	-	91	1369	①/H	-	105
1128	④	-	71	1282	①/N	-	91	1370	①/H	-	105
1132	④	-	68	1283	①/H	-	91	1371	①/H	-	105
1137	④	-	68	1284	①/N	-	91	1372	①/H	-	105
1142	④	-	70	1285	①/N	-	91	1373	①/H	-	105
1147	④	-	70	1286	①/N	-	91	1374	①/H	-	105
1150	④	-	66	1287	①/N	-	91	1375	①/H	-	105
1151	④	-	66	1290 Z	①/N	-	103	1376	①/H	-	105
1152	④	-	66	1292	①/N	-	98	1377	①/H	-	100
1153	④	-	66	1293	①/N	-	98	1379	①/H	-	100
1154	④	-	66	1295	①/N	-	100	1380	②	-	105
1155	④	-	66	1296	①/H	-	98	1381	①/H	-	92
1158	④	-	66	1297	①/H	-	98	1382	①/H	-	92
1159	④	-	66	1297 Z	①/N	-	103	1383	①/H	-	92
1163	-	-	81	1298	①/H	-	98	1384	①/H	-	92
1167	④	-	80	1299	①/N	-	98	1385	①/H	-	92
1175	④	-	80	1300	①/N	-	93	1390	①/H	-	92
1178	④	-	71	1300 Z	①/N	-	93/103	1390 S	①/H	-	92
1178 S	④	-	71	1301	①/N	-	93	1395	①/N	-	104
1180	④	-	71	1302	①/N	-	93	1397	①/N	-	104
1181	④	-	71	1305	①/N	-	93	1455	①/H	-	90
1183	④	-	71	1305 S	①/N	-	93	1456	①/H	-	90
1184	④	-	71	1306	①/N	-	93	1457	①/H	-	90/94
1185	④	-	71	1307	①/N	-	93	1458	①/H	-	90/94
1187	④	-	70	1307 Z	①/N	-	93/103	1459	①/H	-	90/94
1188	④	-	70	1308	①/N	-	93	1460	①/H	-	90
1189	④	-	70	1308 S	①/N	-	77	1461	①/H	-	90
1190	④	-	70	1309	④	-	77	1464	①/H	-	91/122
1194	④	-	70	1309 S	①/N	-	77	1479	①/H	-	100
1195	④	-	70	1310	①/H	-	104	2000	①/H	-	91
1196	④	-	70	1311	①/N	-	104	2001	①/N	-	93
1230	-	-	138	1312	①/H	-	104	2002	①/H	-	100
1235	-	-	138	1313	①/H	-	104	2003	①/H	-	118



## Test requirements for lightning protection components according to EN 62561

Document	Description	Legend	Classification	Document	Description	Legend	Classification	
Part 1	Requirements for connection components	①	H / N	Part 5	Requirements for earth electrode inspection housings and earth electrode seals	⑤		
Part 2	Requirements for conductors and earth electrodes	②		Part 7	Requirements for earthing enhancing compounds	⑦		
Part 3	Requirements for isolating spark gaps	③		Part 8	Requirements for an isolated lightning protection system	⑧	H2 / H1 / H / N	
Part 4	Requirements for conductor fasteners	④		Shortcircuit current (50Hz) (1s; ≤300°C) in kA		I <sub>k</sub>		
Requirements and test methods for surge protection device			Energy technology EN 61643-11				Ⓔ	
			Photovoltaics EN 50539-11				Ⓕ	
			Information technology EN 61643-21				Ⓖ	

### Numerical index

Ord. no.	Tested	I <sub>k</sub>	Page	Ord. no.	Tested	I <sub>k</sub>	Page	Ord. no.	Tested	I <sub>k</sub>	Page
2004	①/H	-	118	100 039	②	13.8	38	103 174	②	-	43
2005	①/H	-	118	100 040	②	17.4	38	103 174 S	②	-	43
2005 S	①/H	-	118	100 041	-	-	38	103 180	②	-	43
2006	①/H	-	96	100 042	-	-	38	103 181	②	-	43
2007	①/H	-	96	100 043	②	-	38	103 182	②	-	43
2008	①/H	-	112	100 058	②	-	38/137	103 183	②	-	43
2008 S	①/H	-	112	100 112	②	3.9	38	103 185	-	-	46
2008 S1	①/H	-	112	100 112 k	②	3.9	38	103 188	-	-	45/46
2008 S2	①/H	-	112	100 114	②	3.9	38	103 189	-	-	44
2009	①/H	-	119	100 114 k	②	3.9	38	103 191	①/H	-	45
2010	①/H	-	119	100 115	②	-	38	103 200	②	-	43
2011	①/H	-	119	100 116	②	-	38	103 250	②	-	43
2012	①/H	-	96	100 118	②	9.7	38	110 001	-	-	67
2013	①/H	-	119	100 121	②	3.5	39	110 002	-	-	67
2014	①/H	-	96	100 123	②	-	39	110 003	-	-	67
2015	①/H	-	112	100 225	②	3.5	38	110 004	-	-	67
2015 S	①/H	-	112	100 336	②	7.4	38	110 006	-	-	67
2016	①/H	-	96	100 336 k	②	7.4	38	110 007	-	-	67
2017	①/H	-	119	100 440	②	11.2	38	110 008	-	-	67
2018	①/H	-	119	100 540	②	14.1	38	110 009	-	-	67
2020	①/H	-	119	100 750	②	-	44/111	110 010	-	-	67
2021	①/H	-	119	101 000	②	-	44/111	110 014	-	-	67
2025	①/H	-	119	101 002	②	-	44/111	110 015	-	-	67
2030	④	-	68	101 005	②	-	44/111	110 018	②	5.3	119
2031	①/H	-	119	101 200	②	-	44/111	110 019	②	12.3	119
2037	④	-	71	101 205	②	-	44/111	110 020	②	7.9	119
2039	④	-	71	101 500	②	-	44/111	110 021	②	7	119
2040	①/H; ②	-	50	101 505	②	-	44/111	110 024	②	12.3	119
2043	①/H	-	96	102 000	②	-	44	110 026	②	5.3	119
2044	①/H	-	96	102 005	②	-	44/111	110 027	②	12.3	119
2046	①/H; ②	-	50	102 075	②	-	111	110 029	②	7.9	119
2056	-	-	120	102 100	②	-	111	110 030	④	-	68
2057	-	-	120	102 120	②	-	111	110 034	④	-	68
2058	-	-	119	102 150	②	-	111	110 034 S3	④	-	68
2059	-	-	119	102 200	②	-	44	110 038 S1	④	-	68
2061	-	-	176	102 205	②	-	44/111	110 045	④	-	68
2062	-	-	176	102 206 S1	②	-	111	110 046	④	-	70
2062 S	-	-	176	102 207	②	-	44/111	110 047	④	-	68
2063	-	-	176	102 208	-	-	174	110 048	④	-	70
2064	-	-	197	102 209	-	-	174	110 050	④	-	68
2072	①/H	39	133	102 211	②	-	111	110 056	④	-	68
2081	-	-	176	102 212	②	-	111	110 056 S3	④	-	68
2084	-	-	176	102 213	②	-	111	110 069	④	-	68
2086	-	-	176	102 214	②	-	111	110 071	④	-	68
2090	-	-	176	102 219	-	-	38/109	110 072	④	-	68
2098	-	-	176	102 220	-	-	38/109	110 073	④	-	70
2100	①/H	-	92	102 233	②	-	111	110 075	④	-	70
2101	①/H	-	92	102 234	②	-	111	110 076	④	-	70
2102	①/H	-	92	102 505	②	-	44/111	110 077	④	-	71
2103	①/H	-	92	102 550	②	-	44	110 078	④	-	71
2104	①/H	-	92	103 100	②	-	43	110 080	④	-	65
2105	①/N	-	92	103 101	-	-	44/51/54	110 081	④	-	65
2106	①/H	-	92	103 102	-	-	44/51/54	110 087	④	-	70
2107	①/H	-	92	103 103	-	-	44/51/54	110 090	④	-	64
2108	①/H	-	50/92	103 104	-	-	45	110 090 S	④	-	64
9105	-	-	133	103 106	②	-	44	110 091	④	-	64
9106	-	-	133	103 110	-	-	44/51/54	110 095	④	-	64
9108	-	-	133	103 111	②	-	43	110 095 S	④	-	64
9110	-	-	133	103 112	②	-	43	110 096	④	-	64
100 008	②	3.5	39	103 113	②	-	43	110 097	-	-	67
100 010	②	5.5	39	103 114	②	-	43	110 098	-	-	67
100 011	②	-	39	103 117	②	-	43	110 099	④	-	68
100 012	②	2.9	39	103 118	-	-	44/51/54	110 100	②	-	111
100 013	②	5.5	39	103 121	②	-	50	110 120	②	4.2	119
100 014	②	-	39	103 122	②	-	50	110 121	②	4.2	119
100 015	②	2.9	39	103 124	②	-	44	110 122	②	4.2	119
100 018	②	-	39	103 125	②	-	50	110 130	②	-	111
100 019	②	-	39	103 128	②	-	43	110 135	②	-	111
100 020	②	-	39	103 137	②	-	44/111	110 140	②	-	111
100 022	②	-	39	103 143	②	-	43	110 145	②	-	111
100 028	②	9.8	39	103 146	-	-	45	110 150	②	-	111
100 029	②	9.8	39	103 147	②	-	44	110 160	④	-	68
100 029 k	②	9.8	39	103 148	②	-	44	110 161	④	-	68
100 030	-	-	38	103 150	②	-	43	110 162	④	-	71
100 033	②	9.5	38	103 158	②	-	50	110 163	④	-	71
100 034	②	13.7	38	103 168	②	-	43	110 164	④	-	70
100 035	②	18.5	38	103 170	②	-	43	110 165	④	-	70
100 036	②	23.4	38	103 171	②	-	43	110 171	④	-	68
100 037	②	7.2	38	103 172	②	-	43	110 172	④	-	68
100 038	②	10.1	38	103 173	②	-	43	110 175	④	-	70





## Numerical index

Ord. no.	Tested	l <sub>k</sub>	Page	Ord. no.	Tested	l <sub>k</sub>	Page	Ord. no.	Tested	l <sub>k</sub>	Page
110 176	④	-	70	111 023 ro	④	-	75	111 271 S	①/H	-	88/98
110 178	④	-	71	111 024	④	-	75	111 272	①/H	-	88/98
110 180	④	-	68	111 027	④	-	76	111 273	①/H	-	88/98
110 181	④	-	71	111 029	④	-	66	111 274	①/H	-	88/98/102
110 182	④	-	70	111 030	④	-	66	111 279	①/H	-	89
110 187	④	-	70	111 031	④	-	65	111 280	①/H	-	89/112
110 189	④	-	68	111 032	④	-	65	111 284	①/N	-	91
110 190	④	-	68	111 033	④	-	73	111 285	①/N	-	91
110 191	④	-	68	111 033 az	④	-	73	111 286	①/N	-	91
110 194	④	-	71	111 035	④	-	73	111 287	①/N	-	91
110 195	④	-	71	111 037	④	-	76	111 296	①/H	-	46
110 196	④	-	70	111 039	④	-	76	111 297	①/H	-	46
110 197	④	-	70	111 043	④	-	75	111 298	①/H	-	46
110 198	④	-	70	111 043 S	④	-	75	111 299	①/H	-	46
110 199	④	-	70	111 044	④	-	75	111 300	①/H;②	-	49
110 200	②	-	111	111 044 S	④	-	75	111 301	①/H;②	-	49
110 205	②	-	111	111 045	④	-	76	111 304	①/N	-	91
110 230	-	-	65/173	111 047	-	-	67	111 305	①/N	-	91
110 240	-	-	44	111 048	-	-	67	111 306	①/N	-	91
110 241	-	-	175	111 049	-	-	67	111 307	①/N	-	91
110 242	-	-	175	111 050	④	-	74	111 308	①/N	-	88
110 243	-	-	175	111 051	④	-	74	111 309	①/N	-	88
110 244	-	-	173	111 052	④	-	74	111 310	①/N	-	88
110 245	-	-	173	111 057	④	-	75	111 313	①/H	-	88/110
110 246	-	-	173	111 057 S	④	-	75	111 314	①/H	-	88
110 247	-	-	173	111 058	④	-	75	111 315	①/H	-	88
110 248	-	-	69/165	111 058 S	④	-	75	111 317	①/H	-	88
110 249	-	-	69	111 061	-	-	175	111 319	①/H	-	88/110
110 250	④	-	69	111 065	③/H	-	175	111 330	①/H	-	117
110 251	④	-	69	111 070	①/N	-	132	111 331	①/H	-	117
110 252	④	-	69	111 075	①/N	-	132	111 332	①/H	-	117
110 253	④	-	69	111 076	①/N	-	132	111 333	①/H	-	117
110 255	④	-	69	111 080	-	-	172	111 334	①/H	-	117
110 256	④	-	69	111 081	-	-	172	111 335	①/N	-	106
110 257	④	-	69	111 082	-	-	39/172	111 336	-	-	106
110 258	④	-	69	111 083	-	-	38/172	111 337	①/H	-	96
110 265	④	-	70	111 084	-	-	172	111 338	①/N	-	106
110 270	④	-	68	111 100	①/N	-	107	111 339	①/H	-	96
110 271	④	-	68	111 120	①/N	-	107	111 340	①/N	-	106
110 272	④	-	68	111 132	④	-	78	111 341	①/H	-	96
110 276	④	-	68	111 133	④	-	78	111 342	①/N	-	106
110 277	④	-	68	111 134	④	-	78	111 343	①/H	-	106
110 278	④	-	70	111 135	④	-	78	111 344	①/H	-	96
110 279	④	-	70	111 136	④	-	78	111 345	①/H	-	96
110 280	④	-	68	111 136 az	④	-	78/84	111 346	-	-	106
110 281	④	-	68	111 136 ro	④	-	78/84	111 347	-	-	106
110 282	④	-	70	111 137	④	-	78	111 348	①/N	-	106
110 283	④	-	70	111 140	④	-	78	111 349	①/N	-	106
110 300	②	-	111	111 141	④	-	78	111 350	①/N	-	106
110 342	-	-	175	111 144	④	-	78	111 352	①/H	-	112
110 343	-	-	175	111 144 az	④	-	78/84	111 353	①/H	-	112
110 441	-	-	175	111 144 ro	④	-	78/84	111 354	①/H	-	112
110 442	-	-	175	111 145	④	-	78	111 355	①/H	-	119
110 443	-	-	175	111 153	④	-	76	111 356	①/H	-	119
110 500	④	-	65	111 157	④	-	75	111 357	①/H	-	119
110 501	④	-	65	111 158	④	-	75	111 362	①/N	-	104
110 502	④	-	65	111 175	④	-	79	111 363	①/N	-	104
110 503	④	-	65	111 176	④	-	79	111 364	①/H	-	104
110 517	④	-	72	111 177	④	-	79	111 365	①/N	-	104
110 520	④	-	78	111 178	④	-	79	111 366	①/H	-	104
110 521	④	-	78	111 191	④	-	79	111 370	①/H	-	91
110 522	④	-	78	111 192	④	-	79	111 371	①/H	-	91
110 523	④	-	78	111 196	④	-	79	111 375	①/H	-	94
110 524	④	-	79	111 197	④	-	79	111 376	①/N	-	100
110 525	④	-	79	111 205	①/N	-	107	111 377	①/N	-	95
110 527	④	-	79	111 207	①/N	-	107	111 379	①/H	-	100
110 528	④	-	79	111 210	①/N	-	107	111 380	①/H	-	100
110 529	④	-	79	111 211	①/N	-	107	111 381	①/H	-	100
110 530	④	-	79	111 212	①/N	-	107	111 382	①/H	-	100
110 531	④	-	79	111 213	①/N	-	107	111 384	①/H	-	101
110 532	④	-	80	111 214	①/N	-	107	111 385	①/H	-	101
110 533	④	-	80	111 215	①/N	-	107	111 386	①/H	-	101
110 538	④	-	79	111 216	①/N	-	107	111 387	①/H	-	101
110 539	④	-	79	111 217	①/N	-	107	111 388	①/H	-	101
110 540	④	-	79	111 222	④	-	69	111 389	①/H	-	101
110 541	④	-	79	111 222 G	④	-	69	111 390	①/H	-	121
110 542	④	-	79	111 225	④	-	69	111 391	①/H	-	121
110 544	④	-	79	111 225 G	④	-	69	111 392	①/H	-	121
110 545	④	-	79	111 227	④	-	69	111 393	①/H	-	121
110 546	④	-	79	111 227 G	④	-	69	111 394	①/H	-	121
110 999	-	-	65	111 232	④	-	69	111 395	①/H	-	121
111 000	-	-	65	111 232 G	④	-	69	111 396	④	-	69/107
111 001	④	-	64	111 235	④	-	69	111 397	④	-	69/107
111 002	④	-	64	111 235 G	④	-	69	111 398	④	-	69/107
111 003	④	-	66	111 237	④	-	69	111 399	④	-	69/107
111 004	④	-	66	111 237 G	④	-	69	111 400	①/H	-	127
111 005	④	-	64	111 240	①/H	-	122	111 402	①/H	-	105
111 006	④	-	64	111 241	①/H	-	122	111 403	①/H	-	105
111 007	④	-	66	111 242	①/H	-	122	111 404	①/H	-	105
111 010	④	-	72	111 243	①/H	-	122	111 405	①/H	-	94
111 010 az	④	-	72	111 244	①/H	-	122	111 406	①/H	-	116
111 010 S	④	-	72	111 245	①/H	-	122	111 407	①/H	-	116
111 010 S1	④	-	72	111 246	①/H	-	122	111 408	①/H	-	116
111 011	④	-	72	111 247	①/H	-	122	111 409	①/H	-	116
111 011 az	④	-	72	111 248	①/H	-	122	111 410	①/H	-	50/90
111 012	④	-	72	111 249	①/H	-	122	111 411	①/H	-	50/90
111 013	④	-	72	111 260	①/N	-	121	111 412	①/H	-	50/90
111 015	④	-	74	111 261	①/H	-	122	111 413	①/H	-	116
111 015 az	④	-	74/84	111 265	④	-	69	111 414	①/H	-	116
111 015 ro	④	-	74/84	111 265 G	④	-	69	111 416	①/H	-	116
111 016	④	-	74	111 266	④	-	69	111 417	①/H	-	116
111 019	④	-	74	111 266 G	④	-	69	111 420	①/H	-	117
111 019 az	④	-	74/84	111 267	④	-	69	111 420 S2	①/H	-	117
111 019 ro	④	-	74/84	111 267 G	④	-	69	111 421	①/H	-	117
111 020	④	-	74	111 270	①/H	-	88/98	111 421 S2	①/H	-	117
111 023	④	-	75	111 270 S	①/H	-	88/98	111 423	①/H	-	117
111 023 az	④	-	75	111 271	①/H	-	88/98	111 423 S	①/H	-	117



## Test requirements for lightning protection components according to EN 62561

Document	Description	Legend	Classification	Document	Description	Legend	Classification
Part 1	Requirements for connection components	①	H / N	Part 5	Requirements for earth electrode inspection housings and earth electrode seals	⑤	
Part 2	Requirements for conductors and earth electrodes	②		Part 7	Requirements for earthing enhancing compounds	⑦	
Part 3	Requirements for isolating spark gaps	③		Part 8	Requirements for an isolated lightning protection system	⑧	H2 / H1 / H / N
Part 4	Requirements for conductor fasteners	④		Shortcircuit current (50Hz) (1s; ≤300°C) in kA		I <sub>k</sub>	
Requirements and test methods for surge protection device				Energy technology EN 61643-11			Ⓔ
				Photovoltaics EN 50539-11			Ⓕ
				Information technology EN 61643-21			Ⓖ

### Numerical index

Ord. no.	Tested	I <sub>k</sub>	Page
111 424	①/H	-	117
111 424 S	①/H	-	117
111 424 S1	①/H	-	117
111 424 S2	①/H	-	117
111 425	①/H	-	112
111 426	①/H	-	112
111 430	①/H	-	50/89/142
111 430 S	①/H	-	142
111 430 S3	①/H	-	143
111 431	④	-	76
111 432	①/H	-	50/89
111 433	①/H	-	50/89
111 434	④	-	76
111 436	④	-	76
111 437	④	-	76
111 440	①/N	-	121
111 441	①/H	-	121
111 442	①/H	-	121
111 445	①/H	-	120
111 445 S	①/H	-	120
111 446	⑦	-	174
111 448	①/H	-	120
111 449	①/N	-	121
111 451	④	-	76
111 452	④	-	76
111 453	④	-	76
111 454	④	-	76
111 458	-	-	120
111 460	-	-	120
111 461	-	-	120
111 463 S	-	-	120
111 464 S	-	-	120
111 465 S	-	-	120
111 466	-	-	120
111 467	-	-	120
111 468	-	-	120
111 478	-	-	120
111 478 S	-	-	120
111 478 S1	-	-	120
111 479	-	-	120
111 479 S	-	-	120
111 479 S1	-	-	120
111 483	④	-	82
111 484	①/N;④	-	82
111 485	①/N;④	-	82
111 486	④	-	82
111 487	④	-	82
111 488	④	-	82
111 490	②/⑧	-	137
111 491	②/⑧	-	137
111 492	②/⑧	-	137
111 493	②/⑧	-	137
111 494	②/⑧	-	137
111 495	②/⑧	-	137
111 496	②/⑧	-	136
111 497	②/⑧	-	136
111 501	④	-	65
111 503	④	-	65
111 505	④	-	65
111 507	④	-	65
111 509	④	-	65
111 510	④	-	65
111 511	④	-	73
111 511 az	④	-	73
111 512	④	-	73
111 513	④	-	73
111 516	④	-	73
111 525	④	-	72
111 525 az	④	-	72
111 525 ro	④	-	72
111 526	④	-	72
111 527	④	-	72
111 527 az	④	-	72
111 527 ro	④	-	72
111 528	④	-	72
111 530	④	-	75
111 530 az	④	-	75
111 530 ro	④	-	75
111 532	④	-	75
111 535	④	-	74

Ord. no.	Tested	I <sub>k</sub>	Page
111 536	④	-	74
111 537	④	-	74
111 540	④	-	74
111 540 az	④	-	74/86
111 540 ro	④	-	74/86
111 541	④	-	74
111 541 az	④	-	74/86
111 541 ro	④	-	74/86
111 545	④	-	74
111 546	④	-	74
111 550	④	-	73
111 551	④	-	73
111 552	④	-	73
111 553	④	-	73
111 576	-	-	120
111 577	-	-	120
111 578	-	-	120
111 580	①/H	-	108
111 585	-	-	108
111 587	①/H	-	108
111 588	-	-	108
111 590	①/N	-	132
111 598	-	-	80
111 600	④	-	81
111 604	④	-	80
111 620	-	-	106
111 623	-	-	106
111 624	-	-	106
111 625	-	-	106
111 626	-	-	106
111 627	-	-	106
111 628	-	-	106
111 629	-	-	106
111 630	④	-	81
111 631	④	-	80
111 632	④	-	80
111 633	④	-	81
111 635	④	-	80
111 639	-	-	106
111 640	-	-	106
111 650	①/N	-	122
111 651	①/N	-	122
111 652	①/N	-	122
111 653	①/N	-	122
111 660	④	-	81
111 661	④	-	80
111 662	④	-	80
111 663	④	-	81
111 666	①/N	-	99
111 667	①/N	-	99
111 669	①/N	-	99
111 670	①/N	-	93
111 671	①/N	-	93
111 672	①/N	-	93
111 673	①/N	-	93
111 674	①/N	-	93/103
111 675	①/N	-	93
111 676	①/N	-	93
111 677	①/N	-	93
111 678	①/N	-	93
111 679	①/N	-	93/103
111 680	①/N	-	98
111 681	①/N	-	98
111 682	①/N	-	98
111 683	①/N	-	98
111 684	①/N	-	98/103
111 685	①/N	-	100
111 686	①/N	-	100
111 687	①/N	-	100
111 688	①/N	-	100
111 689	①/N	-	100/102
111 690	①/H	-	113
111 691	①/H	-	113
111 692	①/H	-	113
111 693	①/H	-	113
111 694	①/H	-	113
111 695	①/H	-	113
111 696	①/H	-	113
111 697	①/H	-	113
111 698	①/N	-	118

Ord. no.	Tested	I <sub>k</sub>	Page
111 699	①/N	-	118
111 700	①/H	6.3	95
111 701	①/H	3.3	95
111 702	①/H	6.3	95
111 703	①/H	3.3	95
111 704	①/H	3.3	95
111 705	①/H	3.3	95
111 710	①/H	-	97
111 711	①/H	-	97
111 712	①/H	-	97
111 713	①/H	-	97
111 714	①/H	-	97
111 715	①/H	-	97
111 716	①/H	-	97
111 717	①/H	-	97
111 718	①/H	-	97
111 719	①/H	-	97
111 720	①/H	-	97
111 721	①/H	-	97
111 722	①/H	-	97
111 723	①/H	-	97
111 724	①/H	-	97
111 725	①/H	-	97
111 726	①/H	-	97/102
111 727	①/H	-	97/102
111 728	①/H	-	97/102
111 729	①/H	-	97/102
111 730	④	-	81
111 731	④	-	81
111 734	①/H	-	101
111 735	①/H	-	101
111 736	①/H	-	101
111 737	①/H	-	101
111 738	①/H	-	101
111 739	①/H	-	101
111 740	①/H	7.4	95
111 741	①/H	3.9	95
111 742	①/H	7.4	95
111 743	①/H	3.9	95
111 744	①/H	3.9	95
111 745	①/H	3.9	95
111 750	④	-	77
111 750 S	④	-	77
111 760	④	-	77
111 761	④	-	77
111 764	④	-	77
111 766	④	-	77
111 768	①/N	-	77
111 769	①/N	-	77
111 779	①/H	-	100
111 780	①/N	-	99/133
111 781	①/N	-	99/133
111 782	①/N	-	99/133
111 784	①/H	-	101
111 785	①/H	-	101
111 786	①/H	-	101
111 787	①/H	-	101
111 788	①/H	-	101
111 789	①/H	-	101
111 790	①/H	-	113
111 791	①/H	-	113
111 792	①/H	-	113
111 793	①/H	-	113
111 794	①/H	-	113
111 795	①/H	-	113
111 796	①/H	-	114
111 797	①/H	-	114
111 798	①/N	-	114
111 799	①/N	-	114
111 800	①/H	-	114
111 802	①/H	-	114
111 804	①/H	-	114
111 806	①/H	-	115
111 807	①/H	-	115
111 808	①/H	-	115
111 809	①/H	-	115
111 810	①/H	-	115
111 811	①/N	-	100
111 812	①/N	-	100
111 813	①/H	-	100



## Numerical index

Ord. no.	Tested	I <sub>k</sub>	Page
111 816	①/H	-	115
111 817	①/H	-	115
111 818	①/H	-	115
111 819	①/H	-	115
111 820	①/H	-	115
111 822	①/H	-	119
111 824	①/H	-	119
111 836	①/H	-	117
111 837	①/H	-	117
111 838	①/H	-	117
111 839	①/H	-	117
111 840	①/H	-	116
111 841	①/H	-	116
111 842	①/H	-	116
111 843	①/H	-	116
111 854	①/H	-	101
111 855	①/H	-	101
111 856	①/H	-	101
111 857	①/H	-	101
111 858	①/H	-	101
111 859	①/H	-	101
111 870	①/H	-	99
111 871	①/H	-	99
111 872	①/H	-	99
111 873	①/H	-	99
111 880	①/H	-	99
111 881	①/H	-	99
111 882	①/H	-	99
111 883	①/H	-	99
111 884	①/H	-	101
111 885	①/H	-	101
111 886	①/H	-	101
111 887	①/H	-	101
111 888	①/H	-	101
111 889	①/H	-	101
111 893	-	-	121
111 894	-	-	121
111 896	④	-	121
111 897	④	-	121
111 898	④	-	121
112 000	①/H	3.3	123
112 002	①/H	7.3	124
112 003	①/H;⑤	3.1	126
112 004	①/H	5	123
112 005	①/H	3.9	127
112 007	①/H	6.2	123
112 008	①/H	8	124
112 009	①/H;⑤	2.2	126
112 010	①/H;⑤	3.1	125
112 011	①/H;⑤	3.1	125
112 012	①/H;⑤	3.1	125
112 013	①/H;⑤	3.1	125
112 017	①/H	3.9	127
112 018	①/H	3.9	127
112 020	①/H	3.3	124
112 021	①/H	3.3	124
112 022	①/H	6.2	124
112 023	①/H	5	124
112 024	①/H	8	124
112 025	①/H	7.3	124
112 027	①/H	-	126
112 039	①/H	3.9	127
112 040	⑤	-	126
112 041	⑤	-	126
112 042	⑤	-	126
112 043	①/H	-	127
112 044	①/H	-	127
112 045	①/H	7.3	127
112 046	①/H	7.3	127
112 047	-	-	127
112 048	-	-	127
112 049	-	-	127
112 050	-	-	127
112 051	-	-	127
112 052	-	-	127
112 053	①/H	3.9	127
112 054	①/H	3.9	127
112 082	①/H	7.3	133
112 100	①/H;⑤	3.3	126
112 113	①/H;⑤	4.3	125
112 114	①/H;⑤	4.3	125
112 115	①/H;⑤	4.3	125
112 130	①/H;⑤	4.3	125
112 150 (M10)	①/H	4.3	123
112 150 (M12)	①/H	3.8	123
112 151 (M10)	①/H	6.5	123
112 151 (M12)	①/H	6.3	123
112 152 (M10)	①/H	5.1	123
112 152 (M12)	①/H	4.9	123
112 153	①/H	6.4	123
112 154	①/H	10.5	124
112 155	①/H	11	123
112 156	①/H;⑤	5.6	125
112 157	①/H;⑤	5.6	125
112 158	①/H;⑤	5.6	125
112 159	①/H;⑤	5.6	125
112 160	①/H;⑤	6.5	125
112 161	①/H;⑤	6.5	125
112 162	①/H;⑤	6.5	125
112 167	①/H;⑤	6.5	125
112 170	①/H;⑤	10.5	125
112 171	①/H;⑤	10.5	125
112 172	①/H;⑤	10.5	125
112 177	①/H;⑤	10.5	125
112 181	①/H;⑤	10.5	125
112 200	①/H	3.3	123
112 202	①/H	7.3	124

Ord. no.	Tested	I <sub>k</sub>	Page
112 203	①/H;⑤	3.1	126
112 204	①/H	5	123
112 207	①/H	6.2	123
112 208	①/H	8	124
112 209	①/H;⑤	2.2	126
112 300	①/H;⑤	3.3	126
112 313	①/H;⑤	4.3	125
112 314	①/H;⑤	4.3	125
112 315	①/H;⑤	4.3	125
112 330	①/H;⑤	4.3	125
112 496	②;⑧	-	136
112 497	②;⑧	-	136
113 029	①/H	-	129
113 030	①/H	-	129
113 085	①/H	-	128
113 105	①/H	-	128
113 123	①/H	-	128
113 133	①/H	-	128
113 216	①/H	-	129
113 231	②	8.5	38
113 260	①/H	-	128
113 290	①/H	-	128
114 400	①/H	-	128
114 550	①/H	-	128
114 700	①/H	-	128
114 850	①/H	-	128
206 004	-	-	197
206 005	-	-	197
206 010	-	-	197
206 011	-	-	197
206 060	-	-	197
206 062	-	-	197
206 063	-	-	197
206 064	-	-	197
206 065	-	-	197
206 281	-	-	197
206 283	-	-	197
206 312	⑥	-	185
206 364	-	-	197
206 366	-	-	197
206 442	-	-	197
206 444	-	-	197
207 000	-	-	197
207 201	-	-	197
207 203	-	-	197
207 301	-	-	197
207 303	-	-	197
207 401	-	-	197
207 403	-	-	197
210 012	①	-	196
210 090	①	-	195
210 110	①	-	196
210 130	①	-	196
210 140	①	-	196
210 160	①	-	196
210 210	①	-	196
210 212	①	-	196
210 228	①	-	196
220 000	①	-	194
220 105	①	-	193
220 112	①	-	193
220 124	①	-	193
220 148	①	-	193
220 160	①	-	193
220 194	①	-	193
220 205	①	-	194
220 212	①	-	194
220 224	①	-	194
220 248	①	-	194
220 260	①	-	194
220 500	①	-	194
220 605	①	-	193
220 612	①	-	193
220 624	①	-	193
220 648	①	-	193
220 660	①	-	193
220 694	①	-	193
220 705	①	-	194
220 712	①	-	194
220 724	①	-	194
220 748	①	-	194
220 760	①	-	194
230 105	①	-	192
230 124	①	-	192
230 605	①	-	192
230 624	①	-	192
240 100	-	-	195
240 190	-	-	195
240 200	-	-	195
240 250	-	-	195
240 300	-	-	195
240 309	-	-	195
240 350	-	-	195
240 351	-	-	195
240 352	-	-	195
240 353	-	-	195
240 451	-	-	195
298 900	①/H	-	122
306 015	-	-	175
306 281	-	-	197
306 281 PV	-	-	197
306 283	-	-	197
306 283 PV	-	-	197
306 330	⑥	-	184
306 331	⑥	-	184
306 332	⑥	-	184
306 333	⑥	-	184

Ord. no.	Tested	I <sub>k</sub>	Page
306 420	⑥	-	185
306 430	⑥	-	185
306 460	⑥	-	185
307 201	-	-	197
307 201 PV	-	-	197
307 203	-	-	197
307 203 PV	-	-	197
316 220	⑥	-	182
316 221	⑥	-	182
316 222	⑥	-	182
316 223	⑥	-	182
316 224	⑥	-	182
316 225	⑥	-	182
316 226	⑥	-	182
316 227	⑥	-	182
316 228	⑥	-	182
316 229	⑥	-	182
316 280	⑥	-	182
316 281	-	-	197
316 282	⑥	-	182
316 286	⑥	-	182
316 441	⑥	-	182
316 443	⑥	-	182
316 701	⑥	-	190
316 705	⑥	-	190
316 711	⑥	-	191
316 712	⑥	-	191
316 741	⑥	-	190
316 745	⑥	-	190
316 751	⑥	-	191
316 752	⑥	-	191
316 761	⑥	-	190
316 762	⑥	-	189
316 765	⑥	-	190
316 766	⑥	-	189
316 781	⑥	-	190
316 782	⑥	-	189
316 785	⑥	-	190
316 786	⑥	-	189
316 792	⑥	-	189
316 796	⑥	-	189
317 200	⑥	-	181
317 201	-	-	197
317 202	⑥	-	181
317 206	-	-	197
317 210	⑥	-	181
317 212	⑥	-	181
317 220	⑥	-	181
317 222	⑥	-	181
317 230	⑥	-	181
317 232	⑥	-	181
317 235	⑥	-	178
317 237	⑥	-	178
317 240	⑥	-	181
317 242	⑥	-	181
317 245	⑥	-	178
317 247	⑥	-	178
317 250	⑥	-	181
317 252	⑥	-	181
317 255	⑥	-	178
317 257	⑥	-	178
317 260	⑥	-	181
317 262	⑥	-	181
317 701	⑥	-	187
317 705	⑥	-	187
317 711	⑥	-	188
317 712	⑥	-	188
317 751	⑥	-	188
317 752	⑥	-	188
317 761	⑥	-	187
317 762	⑥	-	186
317 765	⑥	-	187
317 766	⑥	-	186
317 781	⑥	-	187
317 782	⑥	-	186
317 785	⑥	-	187
317 786	⑥	-	186
317 792	⑥	-	186
317 796	⑥	-	186
327 201	-	-	197
327 210	⑥	-	180
327 212	⑥	-	180
327 220	⑥	-	180
327 222	⑥	-	180
327 230	⑥	-	180
327 232	⑥	-	180
327 240	⑥	-	180
327 242	⑥	-	180
327 250	⑥	-	180
327 252	⑥	-	180
336 130	⑥	-	179
336 140	⑥	-	179
337 133	⑥	-	179
337 143	⑥	-	179
346 220	⑥	-	183
346 222	⑥	-	183
346 223	⑥	-	183
346 225	⑥	-	183
346 228	⑥	-	183
346 229	⑥	-	183
410 000	①/N	-	129
416 000			



## Test requirements for lightning protection components according to EN 62561

Document	Description	Legend	Classification	Document	Description	Legend	Classification
Part 1	Requirements for connection components	①	H / N	Part 5	Requirements for earth electrode inspection housings and earth electrode seals	⑤	
Part 2	Requirements for conductors and earth electrodes	②		Part 7	Requirements for earthing enhancing compounds	⑦	
Part 3	Requirements for isolating spark gaps	③		Part 8	Requirements for an isolated lightning protection system	⑧	H2 / H1 / H / N
Part 4	Requirements for conductor fasteners	④		Shortcircuit current (50Hz) (1s; ≤300°C) in kA		I <sub>k</sub>	
Requirements and test methods for surge protection device				Energy technology EN 61643-11			Ⓔ
				Photovoltaics EN 50539-11			Ⓟ
				Information technology EN 61643-21			Ⓡ

## Numerical index

Ord. no.	Tested	I <sub>k</sub>	Page	Ord. no.	Tested	I <sub>k</sub>	Page	Ord. no.	Tested	I <sub>k</sub>	Page
490 005	④/⑧	-	145	490 700	-	-	144	614 011	④	-	164
490 007	④/⑧	-	145	490 701	-	-	144	614 060	④	-	162
490 008	④/⑧	-	145	490 702	-	-	144	614 070	④	-	162
490 303	-	-	144	490 703	-	-	144	614 100	④	-	162
490 405 V	⑧	-	137	499 000	-	-	54/136	622 000	④	-	161
490 408 V	⑧	-	137	499 005	-	-	55	622 001	④	-	161
490 410 V	⑧	-	137	499 006	-	-	55	622 005	④	-	164
490 430	⑧	-	140	499 007	-	-	55	624 000	④	-	161
490 431	⑧	-	140	499 009	-	-	55	624 001	④	-	161
490 432	⑧	-	140	499 010	-	-	54/136	624 003	④	-	161
490 433	⑧	-	140	499 100	-	-	51/54	624 005	④	-	164
490 433 S	⑧	-	140	499 101	-	-	51/54	624 006	④	-	164
490 443	⑧	-	140	499 500	-	-	55	624 007	④	-	164
490 444	⑧	-	140	499 600	-	-	55	624 010	④	-	163
490 450	⑧	-	141	499 700	-	-	54/136	624 011	④	-	163
490 451	⑧	-	141	600 001	⑧/H1	-	154	624 020	④	-	163
490 452	⑧	-	141	600 002	⑧/H1	-	154	624 021	④	-	163
490 490	④	-	59/138	600 003	⑧/H1	-	154	624 022	④	-	163
490 491	④	-	59/138	600 501	-	-	170	632 000	②,⑧	-	156
490 492	④	-	59/138	600 502	-	-	170	632 001	②,⑧	-	156
490 495	④	-	59/138	600 503	-	-	170	632 002	②,⑧	-	156
490 505	-	-	141	600 504	-	-	170	632 003	②,⑧	-	156
490 506	-	-	141	600 505	-	-	170	632 004	②,⑧	-	156
490 507	-	-	141	600 510	-	-	170	632 005	②,⑧	-	156
490 508	-	-	141	600 520	-	-	170	632 101	②,⑧	-	157
490 513	⑧	-	140	600 530	-	-	170	632 102	②,⑧	-	157
490 514	⑧	-	140	600 540	-	-	170	632 103	②,⑧	-	157
490 515	⑧	-	140	600 550	-	-	170	632 104	②,⑧	-	157
490 530	⑧	-	141	600 560	-	-	170	632 105	②,⑧	-	157
490 531	⑧	-	141	600 561	-	-	170	632 200	②,⑧	-	158
490 532	⑧	-	141	600 562	-	-	170	632 201	②,⑧	-	158
490 535	⑧	-	141	600 571	-	-	169	632 202	②,⑧	-	158
490 536	⑧	-	141	600 573	-	-	169	632 203	②,⑧	-	158
490 540	④	-	59/138/158	600 575	-	-	169	632 204	②,⑧	-	158
490 541	④	-	59/138/158	600 610	-	-	169	632 205	②,⑧	-	158
490 542	④	-	59/138/158	600 611	-	-	169	632 302	②,⑧	-	159
490 543	④	-	59/138/158	600 612	-	-	169	632 303	②,⑧	-	159
490 548	-	-	59/158	600 620	-	-	169	632 304	②,⑧	-	159
490 549	-	-	59/158	600 621	-	-	169	632 305	②,⑧	-	159
490 550	④	-	59/158	601 100	①,⑧/H1	-	154	632 400	①,⑧/H1	-	167
490 551	④	-	59/158	601 100-5	①,⑧/H1	-	155	632 448	④,⑧	-	167
490 552	④	-	59/158	601 101	①,⑧/H1	-	154	632 449	④	-	167
490 553	④	-	59/158	601 101-5	①,⑧/H1	-	155	640 000	-	-	167
490 560	④	-	59/158	601 102	①,⑧/H1	-	154	640 001	-	-	167
490 561	④	-	59/158	601 102-5	①,⑧/H1	-	155	640 002	-	-	167
490 562	④	-	59/158	601 103	①,⑧/H1	-	154	640 003	-	-	167
490 563	④	-	59/158	601 110	-	-	150/151	640 004	-	-	167
490 570	④	-	59/158	601 111	-	-	151/154	640 005	-	-	167
490 571	④	-	59/158	601 112	-	-	155	640 006	-	-	167
490 572	④	-	59/158	601 113	-	-	155	640 007	-	-	167
490 573	④	-	59/158	601 200	①,⑧/H1	-	155	640 010	-	-	167
490 580	-	-	142	602 210	①,⑧/H1	-	169	640 020	-	-	167
490 581	-	-	142	612 001	④	-	160	640 030	-	-	151/155
490 581 S1	④	-	142	612 002	④	-	160	640 040	-	-	167
490 581 S2	④	-	142	612 003	④	-	160	640 041	-	-	167
490 581 S3	④	-	142	612 004	④	-	160	650 001	⑧/H1	-	150
490 581 S4	④	-	142	612 010	④	-	164	650 002	⑧/H1	-	150
490 582	-	-	143	612 011	④	-	164	650 003	⑧/H1	-	150
490 584	-	-	143	612 020	④	-	164	650 501	-	-	170
490 585	-	-	143	612 021	④	-	164	650 502	-	-	170
490 586	-	-	143	612 022	④	-	164	650 505	-	-	170
490 587	-	-	143	612 030	④	-	165	650 510	-	-	170
490 587 S	-	-	143	612 031	④	-	165	650 560	-	-	170
490 588	-	-	143	612 040	④	-	165	650 561	-	-	170
490 588 S	-	-	143	612 041	④	-	165	650 562	-	-	170
490 589	-	-	143	612 045	④	-	165	650 571	-	-	169
490 590	-	-	143	612 046	④	-	165	650 575	-	-	169
490 591	-	-	143	612 047	-	-	165	651 100	①,⑧/H1	-	150
490 591 S	-	-	143	612 050	①,⑧/N	-	166	651 100-5	①,⑧/H1	-	151
490 592	-	-	143	612 051	①,⑧/N	-	166	651 101	①,⑧/H1	-	150
490 592 S	-	-	143	612 060	④	-	162	651 101-5	①,⑧/H1	-	151
490 593	-	-	143	612 070	④	-	162	651 102	①,⑧/H1	-	150
490 593 S	-	-	143	612 080	④	-	161	651 102-5	①,⑧/H1	-	151
490 594	-	-	143	612 081	④	-	161	651 103	①,⑧/H1	-	150
490 620	⑧	-	144	612 082	④	-	161	651 111	-	-	150
490 621	⑧	-	144	612 090	④	-	162	651 113	-	-	151
490 622	⑧	-	144	612 100	④	-	162	651 200	①,⑧/H1	-	151
490 623	⑧	-	144	614 001	④	-	160	652 210	①,⑧/H1	-	169
490 624	⑧	-	144	614 003	④	-	160	662 001	④	-	160
490 625	⑧	-	144	614 010	④	-	164	662 002	④	-	160



## Numerical index

Ord. no.	Tested	I <sub>k</sub>	Page	Ord. no.	Tested	I <sub>k</sub>	Page	Ord. no.	Tested	I <sub>k</sub>	Page
662 003	④	-	160	911 576	④	-	71	912 700	②	-	53
662 004	④	-	160	911 654	④	-	69	912 705	②	-	53
662 010	④	-	164	911 654 S	④	-	69	912 710	②	-	53
662 011	④	-	164	911 688	①/H	-	105	912 715	②	-	53
662 020	④	-	164	912 000	②	-	54	912 720	②	-	53
662 021	④	-	164	912 000 W	②	-	58	912 725	②	-	53
662 022	④	-	164	912 001	②	-	54	912 730	②	-	53
662 030	④	-	165	912 001 W	②	-	58	912 735	②	-	53
662 031	④	-	165	912 002	②	-	54	912 740	②	-	53
662 040	④	-	165	912 002 W	②	-	58	912 745	②	-	53
662 041	④	-	165	912 003	②	-	54	912 750	②	-	53
662 045	④	-	165	912 003 W	②	-	58	912 755	②	-	53
662 046	④	-	165	912 004	②	-	54	912 760	②	-	53
662 047	④	-	165	912 004 W	②	-	58	912 765	②	-	53
662 050	①;⑧/N	-	166	912 005	②	-	54	912 770	②	-	53
662 051	①;⑧/N	-	166	912 005 W	②	-	58	912 800	②/⑧	-	139
662 060	④	-	162	912 006	②	-	54	912 801	②/⑧	-	139
662 070	④	-	162	912 006 W	②	-	58	912 802	②/⑧	-	139
662 080	④	-	161	912 007	②	-	54	912 803	②/⑧	-	139
662 081	④	-	161	912 007 W	②	-	58	913 420	④	-	73
662 082	④	-	161	912 008	②	-	54	913 610	④	-	69
662 090	④	-	162	912 008 W	②	-	58	913 611	④	-	69
662 100	④	-	162	912 009	②	-	54	913 615	④	-	77
664 001	④	-	160	912 009 W	②	-	58	913 616	④	-	77
664 003	④	-	160	912 010	②	-	54	913 617	④	-	77
664 010	④	-	164	912 010 W	②	-	58	913 650	①/H	-	134
664 011	④	-	164	912 011	②	-	54	913 651	①/H	-	134
664 060	④	-	162	912 011 W	②	-	58	913 652	①/H	-	134
664 070	④	-	162	912 013	②	-	54	913 653	①/H	-	134
664 100	④	-	162	912 013 W	②	-	58	913 654	①/H	-	134
672 000	④	-	161	912 015	②	-	54	913 655	①/H	-	134
672 001	④	-	161	912 015 W	②	-	58	913 656	①/H	-	134
672 005	④	-	164	912 019	②	-	54	913 657	①/H	-	134
674 000	④	-	161	912 019 W	②	-	58	913 658	①/H	-	134
674 001	④	-	161	912 061	②	-	53	913 660	①/H	-	134
674 003	④	-	161	912 068	②	-	42	913 661	①/H	-	134
674 005	④	-	164	912 068 S	②	-	42	913 662	①/H	-	134
674 006	④	-	164	912 069	②	-	42	913 666	①/H	-	134
674 007	④	-	164	912 070	②	-	53	913 667	①/H	-	134
674 010	④	-	163	912 075	②	-	42	913 668	①/H	-	134
674 011	④	-	163	912 075 S	②	-	42	913 732	④	-	73
674 020	④	-	163	912 077	②	-	42	913 733	④	-	73
674 021	④	-	163	912 077 S	②	-	42	913 734	④	-	73
674 022	④	-	163	912 078	②	-	42	913 825	-	-	121/143/165
690 020	-	-	167	912 079	②	-	42	913 831	-	-	121/143/165
900 047	①/H	-	118	912 079 S	②	-	42	914 077	⑧	-	144
910 007	①/H	-	118	912 080	②	-	42	914 185	②	-	53
910 009	①/H	39	133	912 081	②	-	42	914 186	②	-	53
910 010	①/H	39	133	912 082	②	-	42	919 860	①/H;②	-	48
910 011	①/H	7.3	133	912 083	②	-	42	919 860 S	①/H;②	-	48
910 012	①/H	7.3	133	912 089	②	-	53	919 860 S1	①/H;②	-	48
910 013	①/H	7.3	133	912 090	②	-	53	920 181	①/H;④	-	48
910 018	①/H	7.3	133	912 091	②	-	53	920 181 S	①/H;④	-	48
910 019	①/H	7.3	133	912 092	②	-	53	920 700	②	-	62
910 020	①/H	7.3	133	912 093	②	-	53	920 701	②	-	62
910 022	①/H	7.3	133	912 094	②	-	53	920 702	②	-	62
910 023	①/H	-	134	912 095	②	-	53	920 703	②	-	62
910 095	②	4.2	119	912 096	②	-	53	920 704	②	-	62
910 096	①/H	-	105	912 097	②	-	53	920 705	②	-	62
910 096 S	①/H	-	105	912 098	②	-	53	920 706	②	-	62
910 097	-	-	81	912 099	②	-	53	920 707	②	-	62
910 101	①/H	-	89	912 119	-	-	146	920 708	②	-	62
910 105	①/N	-	98	912 120	①/N;②;⑧	-	146	920 709	②	-	62
910 107	①/H	-	89	912 121	②;⑧	-	146	920 710	②	-	62
910 139	①/H	39	133	912 122	④	-	146	920 711	②	-	62
910 183	①/N	-	92	912 125	-	-	110	920 860	④	-	48
910 193	①/H	39	133	912 180	①/②	-	60	920 860 B	④	-	48
910 223	①/H	-	134	912 181	①/②	-	61	924 192	①	-	49
910 242	①	-	49	912 182	①/②	-	60	T 14 A 0001 A	-	-	129
910 243	①	-	49	912 183	①/②	-	61	T 14 B 0001 A	-	-	129
910 247	①/H;②	-	49	912 184	①/②	-	60	T 14 B 0002 A	-	-	129
910 248	①/H	-	49	912 185	①/②	-	61	1244 M6X50 GAL	-	-	174
910 257	①/H;②	-	49	912 186	①/②	-	60	1244 M8X50 GAL	-	-	174
910 258	①/H	-	49	912 187	①/②	-	61	125 A 10.5 V2A	-	-	174
910 259	①/H	-	118	912 200	①/②	-	60	125 A 6.4 V2A	-	-	174
910 260	①/H	-	118	912 201	①/②	-	60	125 A 8.4 V2A	-	-	174
910 286	①/H	-	122	912 202	①/②	-	60	127 B 6 V2A	-	-	174
910 301	①/H	-	134	912 203	①/②	-	60	127 B 8 V2A	-	-	174
910 302	①/H	7.3	133	912 204	①/②	-	60	127 B10 V2A	-	-	174
910 305	①/H	-	134	912 205	①/②	-	60	603 M10X30 V2A	-	-	174
910 306	①/H	-	134	912 206	①/②	-	60	7337 5.0X12 ALU/V2A	-	-	105/174
910 307	①/H	-	134	912 207	①/②	-	60	7337 5.0X12 V2A/V2A	-	-	105/174
910 308	①/H	-	134	912 208	①/②	-	60	7504 6.3X19 V2A	-	-	105/174
910 309	①/H	-	134	912 210	①/②	-	61	7981 6.3X19 V2A	-	-	174
910 330	①/H	-	134	912 211	①/②	-	61	7996 5X45 V2A	-	-	174
910 331	①/H	-	134	912 212	①/②	-	61	84 M 6X12 V2A	-	-	174
910 332	①/H	-	134	912 213	①/②	-	61	84 M 6X20 V2A	-	-	174
910 333	①/H	-	134	912 214	①/②	-	61	903 6X40 V2A	-	-	174
910 347	②	44/111	-	912 215	①/②	-	61	903 8x120	-	-	174
910 359	①/H	-	133	912 216	①/②	-	61	903 8x220	-	-	174
910 375	①/H	39	133	912 217	①/②	-	61	903 8X40	-	-	174
910 380	①/H	-	134	912 218	①/②	-	61	933 M 6X25 V2A	-	-	174
910 382	①/H	39	133	912 240	①/②	-	60	933 M 8X25 V2A	-	-	174
910 385	①/H	7.3	133	912 400	②	-	58	933 M10X25 V2A	-	-	174
910 494	①/H	-	118	912 401	②	-	58	934 M 6 V2A	-	-	174
910 527	①/H	39	133	912 402	②	-	58	934 M 8 V2A	-	-	174
910 540	①/H	39	133	912 403	②	-	58	934 M10 V2A	-	-	174
910 544	①/H	-	134	912 500	②	-	51				
910 545	①/H	-	134	912 501	②	-	51				
910 572	①/H	-	122	912 502	②	-	51				
910 579	①/H	-	96	912 505	①/H;②	-	49				
911 178	①/N	-	105	912 506	①/H	-	49				
911 224	①/H	-	89	912 600	②	-	56				
911 280	④	-	69	912 601	②	-	56				
911 280 S	④	-	69	912 602	②	-	56				
911 314	④	-	71	912 603	②	-	56				
911 575	④	-	71	912 605	①/②/⑧	-	139				



## Factories and distribution centres:

### Factory I:

J. Pröpster GmbH  
 Regensburger Str. 116  
 D-92318 Neumarkt/OPf.  
 Germany  
 Phone +49 9181 2590-0  
 Fax +49 9181 2590-10  
 Email: info@proepster.de

### Factory II:

J. Pröpster GmbH  
 Lerchenstraße 48  
 D-09669 Frankenberg  
 Germany  
 Phone +49 37206 2592  
 Fax +49 37206 2821

### Factory III:

J. Pröpster GmbH  
 Gewerbepark C 1  
 D-92364 Deining  
 Germany  
 Phone +49 9181 2590-0  
 Fax +49 9181 2590-10  
 Email: info@proepster.de



## International representatives:

 **Hungary**  
 REX - Elektó Kft.  
 1155 Budapest  
 Phone +36 138 885 47  
 info@proepster.hu

 **Italy**  
 Konrad Stauder  
 39058 Sarentino / Bolzano  
 Phone +39 0471 622 655  
 konrad.stauder@rolmail.net

 **Bulgaria**  
 Blitz Guard LTD  
 1421 Sofia  
 Phone +35 929 63 13 22  
 blitzguard@techno-link.com

 **Czech Republic**  
 Hromosvodní technika M.P., s.r.o.  
 16000 Praha  
 Phone +420 603 816 081  
 proepster@proepster.cz

 **Croatia**  
 EIT Elektroinstalacijska tehnika d.o.o.  
 10090 Zagreb  
 Phone +385 1 3498 100  
 eit@eit.hr

 **Serbia**  
 EIT Elektroinstalacijska tehnika d.o.o.  
 10090 Zagreb CROATIA  
 Phone +385 1 3498 100  
 eit@eit.hr

 **Columbia**  
 POWERCOL S.A.S.  
 Bogota - Columbia  
 Phone +57 153 33 122  
 gerencia@powercol.com

 **Albania**  
 Bliz Guard d.o.o.e.l.  
 Skopje NORTH MACEDONIA  
 Phone +389 76 200 458  
 skopje@blitzguard.com

 **Belarus**  
 Baltic Lightning Protection Ltd.  
 1084 Riga LATVIA  
 Phone +371 295 557 95  
 ervins.elksnis@blp.lv

 **Belgium**  
 NBR Nussbaumer nv/sa  
 1500 Halle  
 Phone +32 23 57 09 40  
 info@nussbaumer.be

 **Latvia**  
 Baltic Lightning Protection Ltd.  
 1084 Riga  
 Phone +371 295 557 95  
 ervins.elksnis@blp.lv

 **Estonia**  
 Baltic Lightning Protection Ltd.  
 1084 Riga LATVIA  
 Phone +371 295 557 95  
 ervins.elksnis@blp.lv

 **Lithuania**  
 Baltic Lightning Protection Ltd.  
 1084 Riga LATVIA  
 Phone +371 295 557 95  
 ervins.elksnis@blp.lv

 **Bosnia-Herzegovina**  
 EIT Elektroinstalacijska tehnika d.o.o.  
 10090 Zagreb CROATIA  
 Phone +385 1 3498 100  
 eit@eit.hr

 **Sweden**  
 AB ELROND Komponent AB  
 14130 Huddinge  
 Phone +46 844 980 80  
 info@elrond.se

 **Lebanon**  
 Polaris Automation Systems SARL  
 Jounieh  
 Phone +961 9 853 639  
 polaris@polarisleb.com

 **North Macedonia**  
 Bliz Guard d.o.o.e.l.  
 Skopje  
 Phone +389 76 200 458  
 skopje@blitzguard.com

 **South Africa**  
 H.H.K. Earthing & Lightning Protection  
 Johannesburg  
 Phone +27 11 476 6917  
 info@hkh.co.za

 **Botswana**  
 H.H.K. Earthing & Lightning Protection  
 Johannesburg - SOUTH AFRICA  
 Phone +267 397 3000  
 info@hkh.co.za

 **Netherlands**  
 Alhadra B.V.  
 3151 XP Hoek van Holland  
 Phone +31 174 386 641  
 alhadra@planet.nl

 **Switzerland**  
 Vontobel Verbindungstechnik  
 8807 Freienbach  
 Phone +41 554 517 570  
 info@vvttechnik.ch

 **Greece**  
 Technical Development LTD  
 121 32 Peristeri - Athens  
 Phone +30 210 578 2008  
 info@technical-development.gr

 **Russia**  
 Baltic Lightning Protection Ltd.  
 1084 Riga LATVIA  
 Phone +371 295 557 95  
 ervins.elksnis@blp.lv

 **Slovenia**  
 EIT Elektroinstalacijska tehnika d.o.o.  
 10090 Zagreb CROATIA  
 Phone +385 1 3498 100  
 eit@eit.hr

 **Denmark**  
 Dan Delektron A/S  
 7080 Børkop  
 Phone +45 701 088 88  
 mail@dandel.dk

 **Ukraine**  
 Baltic Lightning Protection Ltd.  
 1084 Riga LATVIA  
 Phone +371 295 557 95  
 ervins.elksnis@blp.lv

 **Kosovo**  
 Bliz Guard d.o.o.e.l.  
 Skopje NORTH MACEDONIA  
 Phone +389 76 200 458  
 skopje@blitzguard.com

 **Namibia**  
 H.H.K. Earthing & Lightning Protection  
 Johannesburg - SOUTH AFRICA  
 Phone +264 61 308 935  
 hhknam@iway.na

# TERMS OF SALE AND DELIVERY

## for commercial business transactions

THIS IS AN ENGLISH TRANSLATION FOR INFORMATION PURPOSES ONLY. FOR ALL LEGAL PURPOSES REFERENCE SHOULD BE MADE TO THE GERMAN ORIGINAL

### 1. General:

All deliveries are subject to our terms, even if the customer specifies different terms. Any arrangements that have not been included in the confirmed order or that have not been confirmed by us in writing, are non-binding.

On publishing the new main catalogue all previously existing prices and price agreements lose their validity.

### 2. Quotation:

If not arranged otherwise, our quotations are non-binding and without engagement.

We do not accept any responsibility or liability whatsoever for the functionality of products manufactured according to the customer's drawings or for any other defects which may occur as a result of the customer's instructions. Documents, such as diagrams, drawings, information about weight and dimensions of products represent approximations only; unless such information is described as "binding". We reserve the copyright for all cost estimates, drawings and other documents. Any such documents become our property and may not be disclosed to third parties. Any infringements are liable for full damages. In case of infringement, we also reserve the right to withdraw immediately from a contract. Constructional designs are also subject to change. Drawings and other documents included in our bids must be returned to us or remunerated on request or, if we have not been granted the contract, immediately. The amount payable will be determined by us based on economic factors at our reasonable discretion.

### 3. Order – Completion of the contract:

Orders are not valid until they have been confirmed by us in writing. A commercial invoice may also serve as order confirmation.

### 4. Prices

All prices are in EURO excluding sales tax. Unless otherwise agreed, prices are stated ex works, including standard packaging. Sales tax will be calculated based on the valid rate on the day of delivery. Any discounts will be deducted from the list prices. We reserve the right to re-calculate the prices for products or energy costs that are associated with an official authorization, if the official authorization takes effect in the time between contracting and product delivery. Additionally, we also reserve the right for a re-calculation, if collectively agreed upon wage and salary increases have taken effect in the time between contracting and product delivery. The prices listed for components made of copper, brass or red brass are based on a DEL copper quote of 500.00 EUROS. Should the DEL quote increase by more than 12.78 EUROS per 100 kg, we will charge an additional non-ferrous metal fee. The price calculation is based on the DEL quote on the day after receipt of the clarified order. If one of our cost price factors is excluded from the price fixing process and a traceable cost price factor arises subsequently, we will be authorized to re-calculate the price, if the price increase occurs in the time between contracting and product delivery. The prices listed are non-binding, recommended prices. Our products may be resold at a higher or lower price by our customers.

### 5. Terms of payment

Unless otherwise agreed in writing, all payments must be made either within 8 days after invoice date with a 2% cash discount or in full within 30 days after invoice date. Payment is automatically considered overdue the day after these appointed payment dates have expired. A payment reminder to establish the debt is not required.

We reserve the right to appropriate any payments made first to the cost, then to the interest and thereafter to the oldest, still outstanding invoices, even if the customer makes different stipulations at the time of making a payment. If, after conclusion of the contract, it comes to our notice through our enquiries and other facts that it is, at our discretion, not advisable to allow the customer credit to the amount of the invoice we will be entitled to ask for advance payments, security for all deliveries or to withdraw from the contract. If advanced payments or security deposits are not made within the time period stipulated by us, we are entitled to claim damages due to default. If the customer falls behind with making partial or full payment, all of our payment claims become due immediately.

The customer has no right to retain or reject the services owed to him. From the due date of the payment, the customer will be charged with interest on arrears which is 2% higher than the interest normally charged by our bank. For orders with a net value (value of items without shipping costs and sales tax) of less than EURO 40.00, an extra charge of EURO 5.00 for small quantities will be invoiced. Cash sales are excluded.

### 6. Reservation of title

We reserve the right of ownership in respect of the goods supplied until such time as all claims under the business relationship with the partner have been met. The customer's claims from the resale of the reserved goods and/or further manufacturing steps involving the use of our goods are fully transferred to us. Passing on our goods is only permitted within the context of proper business operations. In the event that the customer sells or delivers the reserved goods, with or without further processing, together with other goods that are not our property, then the assignment of the accounts receivable resulting from the resale only applies to the value of the reserved goods. The customer has no other rights of disposal concerning the reserved goods. At our request the customer is obliged to inform us about his customer and the agreed selling price and to inform his customer of any assignment to us.

### 7. Delivery

The agreed delivery times commence on the day on which the contract becomes legally effective. Unforeseen events, such as war, mobilization, natural phenomena, disturbances of normal factory operations which are beyond our control, delayed delivery or quality defects of raw materials, etc., damage to important workpieces, or difficulties of various kinds due to unstable economic conditions, entitle us to extend the delivery time by the time required to deal with these events. We are also entitled to withdraw from the contract if any such events occur, even if the delivery time has already been extended. Such circumstances neither entitle the customer to withdraw from the contract nor to claim damages.

### 8. Shipping

The delivery is considered to have been effected as soon as the goods have left the factory or the warehouse, even if delivery carriage paid has been arranged. Upon request by and at the expense of the customer, we can insure the consignment against breakage, fire and transport damage.

### 9. Warranty and liability

The customer or his representative must inform us immediately on receipt of the goods in writing about any immediately apparent defects and any latent defects which are discovered upon careful inspection of the goods delivered, including incomplete delivery. We are entitled to take back faulty goods, to issue a credit note or to replace with faultless goods, if the defect has been claimed immediately. This also applies to defects that were not recognized during the immediate entry inspection. We shall not assume liability for any damage caused by incorrect installation or modifications made to the product. Further claims by the customer, such as redhibitory action, reduction of the purchasing price, compensation, as well as claims brought forth by third parties are excluded. We are not liable for any damage not deriving from the delivered goods themselves. In particular, we are not liable for lost profit or other financial losses incurred by the customer. The aforementioned limitations of liability do not apply in the case of specific intent or gross negligence. They also do not apply if the customer has claimed damages due to default because the product is lacking an advertised property according to §§ 463, 480 II BGB (German Civil Code). Compensation is limited to foreseeable damage. In the event that we violate a cardinal duty or a contractual obligation through negligence or we are responsible for a culpa in contrahendo we are liable only for standard contractual loss or loss which might reasonably have been expected.

We deliver only functional goods. A warranty for using the goods for the purpose intended by the customer can only be given, if we have issued our express written consent.

So far as our liability for damages is excluded or limited, it can also be applied to any other claims, including claims due to culpa in contrahendo, infringement of minor obligations and claims arising from the producer's liability according to § 823 BGB (German Civil Code).

The above paragraph does not apply to claims according to §§ 1, 4 of the Produkthaftungsgesetz (German Product Liability Law) or in cases of inability or impossibility.

So far as our liability is excluded or limited this also applies to the personal liability of our employees, representatives, deputies and assistants.

Any liability claims cease in agreement with § 477 BGB (German Civil Code), excluding claims arising from the producer's liability according to §§ 823 cont. BGB (German Civil Code).

### 10. Returning material

Delivered products can only be returned in exceptional cases and only with our approval. The goods must be in their original packaging. Goods which were delivered more than 3 months ago cannot be returned.

In order to cover the costs of handling returned goods, we charge a return fee amounting to 10% of the goods' net value. If, for special reasons, we agree to take back unpacked parts or parts that are not in their original packaging, a fee for new packaging amounting to 10% will be added to the return fee. Transport costs for returned goods will not be paid by us.

### 11. Data privacy

The customer's data concerning our business relationship with him will be handled according to the German Federal Data Protection Law.

### 12. Place of fulfilment, place of jurisdiction

German law is applicable to these terms of sale and delivery and to the entire legal relationship between the contractual partners. The UN Convention on Contracts for the International Sale of Goods (CISG) from 04/11/1980 is not applicable.

Place of fulfilment and jurisdiction for delivery, payment and all liabilities, including any action relating to payment by bill of exchange or cheque, is the town of Neumarkt/Opf. Invalidation of one part of these terms of delivery does not affect the other parts of this agreement. In this case, the invalid part is replaced by the current legal regulation. Any changes or alterations to these terms of delivery require the written consent of the seller.

Sales tax identification no.: DE 133211151 J. Pröpster GmbH.

Register of companies Nuremberg, HRB 8169,

Managing directors: Johann Pröpster; Prof. Dr. h.c. Dipl. Ing. Johann Pröpster



Insulated lightning protection



HVC-Conductor



Earthing kit  
DB approved

## J. Pröpster GmbH Specialist manufacturer of lightning protection and earthing materials

### Factory I:

Regensburger Str. 116  
D-92318 Neumarkt/OPf.  
Germany

Phone +49 9181 2590-0

Fax +49 9181 2590-10

Email: [info@proepster.de](mailto:info@proepster.de)

Internet: [www.proepster.de](http://www.proepster.de)

### Factory II:

Lerchenstraße 48  
D-09669 Frankenberg  
Germany

Phone +49 37206 2592

Fax +49 37206 2821

Email: [info@proepster.de](mailto:info@proepster.de)

Internet: [www.proepster.de](http://www.proepster.de)

### Factory III:

Gewerbepark C1  
D-92364 Deining  
Germany

Phone +49 9181 2590-0

Fax +49 9181 2590-10

Email: [info@proepster.de](mailto:info@proepster.de)

Internet: [www.proepster.de](http://www.proepster.de)